



LUNDS  
UNIVERSITET

Elektro- och informationsteknik

# Tentamen i Digitalteknik, EITF65

3 januari 2018, kl. 14-19

- ▶ Skriv anonymkod och identifierare, eller personnummer, på alla papper.
- ▶ Börja en ny uppgift på ett nytt papper. Använd bara en sida av pappret.
- ▶ Lösningarna skall tydligt visa tillvägagångssättet.
- ▶ Minimering av funktioner, var och en för sig, ses som en naturlig del av lösningen. Minimalt antal tillstånd i tillståndsgrafer förväntas. Metoder för bra tillståndskodning behöver ej användas om det inte efterfrågas i uppgiften.
- ▶ Om det efterfrågas skall kopplingar för realiseringar ritas.
- ▶ Hjälpmedel: kursboken, föreläsningbilder och föreläsninganteckningar (allt under fliken "föreläsningar"), samt enkel miniräknare.

Lycka till!

---

## Uppgift 1

Betrakta följande funktion i fem variabler, som ska realiseras i disjunktiv form

$$f^{-1}(1) = \{0, 2, 10, 13, 15, 16, 18, 19, 20, 21, 24, 26, 28\},$$

$$f^{-1}(-) = \{5, 7, 8, 9, 11, 22, 23\}.$$

- (a) Ange samtliga primimplikatorer samt vilka av dem som är väsentliga.
- (b) Realisera funktionen i minimal form. Ange dess booleska uttryck.

(4+6=10p)

---

## Uppgift 2

Du ansvarar för konstruktion av ett digitalt system som skall detektera ett visst insignalbeteende. Insignalen vid varje tidpunkt  $t$  består av två binära värden  $x_0(t)$ ,  $x_1(t)$ . När ekvationen  $x_0(t) + x_0(t-1) + x_0(t-2) = 2x_1(t)$  (ekvation över heltalen) är sann så ska utsignalen  $y(t) = 1$  vara ett, annars skall den vara noll. Systemet startas vid  $t = 0$  och för  $t < 0$  så gäller  $x_0(t) = x_1(t) = 0$ .

Exempelvis så ger insignalen

11, 01, 11, 10, 11, 01, 11, 01, 00, 00, 01, ...

utsignal

0, 0, 1, 0, 0, 1, 1, 0, 0, 1, 0, ...

Insignalen är då given som  $x_0(t)$ ,  $x_1(t)$  för  $t = 0, 1, 2, \dots$

Eftersom början av sekvensen 11, 01, 11 ger  $x_0(0) = 1$ ,  $x_0(1) = 0$ ,  $x_0(2) = 1$  och  $x_1(2) = 1$  så gäller  $x_0(2) + x_0(1) + x_0(0) = 1 + 0 + 1 = 2 = 2x_1(2)$  och då blir  $y = 1$  vid tidsenhet 2, etc.

- (a) Ta fram en tillståndsgraf för problemet. Minimera grafen.
- (b) Realisera ett sekvensnät med minimalt antal D-vippor som implementerar den givna detektorn. Ange funktioner i minimal form. Rita sekvensnätet!

(5+5=10p)

---

## Uppgift 3

I denna uppgift ska en stack realiseras, som en modul av ett större system. Stacken som ska implementeras ska i varje cell kunna lagra ett värde som är 6 bitar långt. **Dessutom ska stacken klara av att lagra upp till 8 värden.**

I Figur 3.1 ses stacken med dess in- och utsignaler. Observera antalet bitar för de olika signalerna. Stackens tillstånd ska ändras vid klocksignalens `clk` stigande flank. Utsignal `ToS` (Top-of-Stack) ges av stackens översta cell. Signalen `n_rst` är en synkron aktiv låg resetsignal som nollställer stackens celler. Signal `StackOp` ska styra stacken enligt tabellen nedan

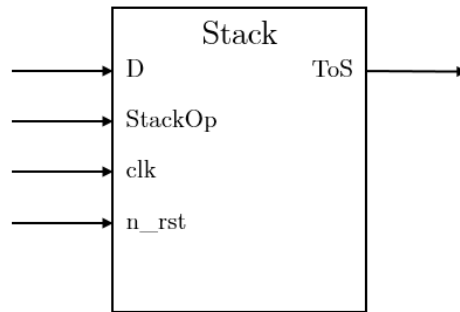

**Figur 3.1:** Symbol av stacken som ska implementeras. Anslutningarna `D` och `ToS` är 6 bitar breda och `StackOp` 2 bitar bred.

| StackOp | Funktion                                                                                       |
|---------|------------------------------------------------------------------------------------------------|
| PUSH    | Värdet av <code>D</code> sparas överst på stacken. tidigare sparade värdet trycks ned ett steg |
| POP     | Stackens innehåll flyttas upp ett steg. och den understa cellen får värdet 0.                  |
| HOLD    | Stackens innehåll oförändrat                                                                   |

Nedan ges ett exempel på hur stacken ska bete sig vid de olika operationerna.

|                                                                                                                                                                                                                                                                                                                                                                                                                                                                                                                                                                                                                                                                                                                                                                                                                                                                                                                                                                                                                                                                                                                                                                                                                                                                                                                                                                                                                                                                                                                                                                                                                                                                                                                                                                                                                                                                                                                                                                                             |                     |                  |   |  |  |   |  |  |   |  |  |   |  |  |   |  |  |   |  |  |   |  |  |   |  |  |   |                  |    |   |  |  |   |  |  |   |  |  |   |  |  |   |  |  |   |  |  |   |  |  |   |  |  |   |                                                                                                                                                                                                                                                                                                                                                                                                                                                                                                                                                                                                                                                                                                                                                                                                                                                                                                                                                                                                                                                                                                                                                                                                                                                                                                                                                                                                                                                                                                                                                                                                                     |                  |   |   |  |  |   |  |  |   |  |  |   |  |  |   |  |  |   |  |  |   |                  |   |   |  |  |   |  |  |   |  |  |   |  |  |   |  |  |   |  |  |   |                                                                                                                                                                                                                                                                                                                                                                                                                                                                                                                                                                                                                                                                                                                                                                                                                                                                                                                                                                                                                                                                                                                                                                                                                                                                                                                                                                                                                                                                                                                                                                                                                                                                                                                                                                                                |                  |   |   |  |  |   |  |  |   |  |  |   |  |  |   |  |  |   |  |  |   |  |  |   |                  |   |   |  |  |   |  |  |   |  |  |   |  |  |   |  |  |   |  |  |   |  |  |   |
|---------------------------------------------------------------------------------------------------------------------------------------------------------------------------------------------------------------------------------------------------------------------------------------------------------------------------------------------------------------------------------------------------------------------------------------------------------------------------------------------------------------------------------------------------------------------------------------------------------------------------------------------------------------------------------------------------------------------------------------------------------------------------------------------------------------------------------------------------------------------------------------------------------------------------------------------------------------------------------------------------------------------------------------------------------------------------------------------------------------------------------------------------------------------------------------------------------------------------------------------------------------------------------------------------------------------------------------------------------------------------------------------------------------------------------------------------------------------------------------------------------------------------------------------------------------------------------------------------------------------------------------------------------------------------------------------------------------------------------------------------------------------------------------------------------------------------------------------------------------------------------------------------------------------------------------------------------------------------------------------|---------------------|------------------|---|--|--|---|--|--|---|--|--|---|--|--|---|--|--|---|--|--|---|--|--|---|--|--|---|------------------|----|---|--|--|---|--|--|---|--|--|---|--|--|---|--|--|---|--|--|---|--|--|---|--|--|---|---------------------------------------------------------------------------------------------------------------------------------------------------------------------------------------------------------------------------------------------------------------------------------------------------------------------------------------------------------------------------------------------------------------------------------------------------------------------------------------------------------------------------------------------------------------------------------------------------------------------------------------------------------------------------------------------------------------------------------------------------------------------------------------------------------------------------------------------------------------------------------------------------------------------------------------------------------------------------------------------------------------------------------------------------------------------------------------------------------------------------------------------------------------------------------------------------------------------------------------------------------------------------------------------------------------------------------------------------------------------------------------------------------------------------------------------------------------------------------------------------------------------------------------------------------------------------------------------------------------------|------------------|---|---|--|--|---|--|--|---|--|--|---|--|--|---|--|--|---|--|--|---|------------------|---|---|--|--|---|--|--|---|--|--|---|--|--|---|--|--|---|--|--|---|------------------------------------------------------------------------------------------------------------------------------------------------------------------------------------------------------------------------------------------------------------------------------------------------------------------------------------------------------------------------------------------------------------------------------------------------------------------------------------------------------------------------------------------------------------------------------------------------------------------------------------------------------------------------------------------------------------------------------------------------------------------------------------------------------------------------------------------------------------------------------------------------------------------------------------------------------------------------------------------------------------------------------------------------------------------------------------------------------------------------------------------------------------------------------------------------------------------------------------------------------------------------------------------------------------------------------------------------------------------------------------------------------------------------------------------------------------------------------------------------------------------------------------------------------------------------------------------------------------------------------------------------------------------------------------------------------------------------------------------------------------------------------------------------|------------------|---|---|--|--|---|--|--|---|--|--|---|--|--|---|--|--|---|--|--|---|--|--|---|------------------|---|---|--|--|---|--|--|---|--|--|---|--|--|---|--|--|---|--|--|---|--|--|---|
| <p>PUSH</p> <p>Före:</p> <table style="display: inline-table; border-collapse: collapse;"> <tr><td style="border: 1px solid black; padding: 2px;"><code>D</code> = 20</td><td style="padding: 0 10px;"><code>ToS</code></td><td style="border: 1px solid black; padding: 2px;">2</td></tr> <tr><td></td><td></td><td style="border: 1px solid black; padding: 2px;">0</td></tr> <tr><td></td><td></td><td style="border: 1px solid black; padding: 2px;">0</td></tr> <tr><td></td><td></td><td style="border: 1px solid black; padding: 2px;">0</td></tr> <tr><td></td><td></td><td style="border: 1px solid black; padding: 2px;">0</td></tr> <tr><td></td><td></td><td style="border: 1px solid black; padding: 2px;">0</td></tr> <tr><td></td><td></td><td style="border: 1px solid black; padding: 2px;">0</td></tr> <tr><td></td><td></td><td style="border: 1px solid black; padding: 2px;">0</td></tr> <tr><td></td><td></td><td style="border: 1px solid black; padding: 2px;">0</td></tr> </table> <p>Efter:</p> <table style="display: inline-table; border-collapse: collapse;"> <tr><td style="border: 1px solid black; padding: 2px;"><code>ToS</code></td><td style="padding: 0 10px;">20</td><td style="border: 1px solid black; padding: 2px;">2</td></tr> <tr><td></td><td></td><td style="border: 1px solid black; padding: 2px;">2</td></tr> <tr><td></td><td></td><td style="border: 1px solid black; padding: 2px;">0</td></tr> <tr><td></td><td></td><td style="border: 1px solid black; padding: 2px;">0</td></tr> <tr><td></td><td></td><td style="border: 1px solid black; padding: 2px;">0</td></tr> <tr><td></td><td></td><td style="border: 1px solid black; padding: 2px;">0</td></tr> <tr><td></td><td></td><td style="border: 1px solid black; padding: 2px;">0</td></tr> <tr><td></td><td></td><td style="border: 1px solid black; padding: 2px;">0</td></tr> <tr><td></td><td></td><td style="border: 1px solid black; padding: 2px;">0</td></tr> </table> | <code>D</code> = 20 | <code>ToS</code> | 2 |  |  | 0 |  |  | 0 |  |  | 0 |  |  | 0 |  |  | 0 |  |  | 0 |  |  | 0 |  |  | 0 | <code>ToS</code> | 20 | 2 |  |  | 2 |  |  | 0 |  |  | 0 |  |  | 0 |  |  | 0 |  |  | 0 |  |  | 0 |  |  | 0 | <p>POP</p> <p>Före:</p> <table style="display: inline-table; border-collapse: collapse;"> <tr><td style="border: 1px solid black; padding: 2px;"><code>ToS</code></td><td style="padding: 0 10px;">1</td><td style="border: 1px solid black; padding: 2px;">2</td></tr> <tr><td></td><td></td><td style="border: 1px solid black; padding: 2px;">3</td></tr> <tr><td></td><td></td><td style="border: 1px solid black; padding: 2px;">4</td></tr> <tr><td></td><td></td><td style="border: 1px solid black; padding: 2px;">5</td></tr> <tr><td></td><td></td><td style="border: 1px solid black; padding: 2px;">6</td></tr> <tr><td></td><td></td><td style="border: 1px solid black; padding: 2px;">7</td></tr> <tr><td></td><td></td><td style="border: 1px solid black; padding: 2px;">8</td></tr> </table> <p>Efter:</p> <table style="display: inline-table; border-collapse: collapse;"> <tr><td style="border: 1px solid black; padding: 2px;"><code>ToS</code></td><td style="padding: 0 10px;">2</td><td style="border: 1px solid black; padding: 2px;">3</td></tr> <tr><td></td><td></td><td style="border: 1px solid black; padding: 2px;">4</td></tr> <tr><td></td><td></td><td style="border: 1px solid black; padding: 2px;">5</td></tr> <tr><td></td><td></td><td style="border: 1px solid black; padding: 2px;">6</td></tr> <tr><td></td><td></td><td style="border: 1px solid black; padding: 2px;">7</td></tr> <tr><td></td><td></td><td style="border: 1px solid black; padding: 2px;">8</td></tr> <tr><td></td><td></td><td style="border: 1px solid black; padding: 2px;">0</td></tr> </table> | <code>ToS</code> | 1 | 2 |  |  | 3 |  |  | 4 |  |  | 5 |  |  | 6 |  |  | 7 |  |  | 8 | <code>ToS</code> | 2 | 3 |  |  | 4 |  |  | 5 |  |  | 6 |  |  | 7 |  |  | 8 |  |  | 0 | <p>HOLD</p> <p>Före:</p> <table style="display: inline-table; border-collapse: collapse;"> <tr><td style="border: 1px solid black; padding: 2px;"><code>ToS</code></td><td style="padding: 0 10px;">1</td><td style="border: 1px solid black; padding: 2px;">1</td></tr> <tr><td></td><td></td><td style="border: 1px solid black; padding: 2px;">2</td></tr> <tr><td></td><td></td><td style="border: 1px solid black; padding: 2px;">3</td></tr> <tr><td></td><td></td><td style="border: 1px solid black; padding: 2px;">4</td></tr> <tr><td></td><td></td><td style="border: 1px solid black; padding: 2px;">5</td></tr> <tr><td></td><td></td><td style="border: 1px solid black; padding: 2px;">6</td></tr> <tr><td></td><td></td><td style="border: 1px solid black; padding: 2px;">7</td></tr> <tr><td></td><td></td><td style="border: 1px solid black; padding: 2px;">8</td></tr> </table> <p>Efter:</p> <table style="display: inline-table; border-collapse: collapse;"> <tr><td style="border: 1px solid black; padding: 2px;"><code>ToS</code></td><td style="padding: 0 10px;">1</td><td style="border: 1px solid black; padding: 2px;">1</td></tr> <tr><td></td><td></td><td style="border: 1px solid black; padding: 2px;">2</td></tr> <tr><td></td><td></td><td style="border: 1px solid black; padding: 2px;">3</td></tr> <tr><td></td><td></td><td style="border: 1px solid black; padding: 2px;">4</td></tr> <tr><td></td><td></td><td style="border: 1px solid black; padding: 2px;">5</td></tr> <tr><td></td><td></td><td style="border: 1px solid black; padding: 2px;">6</td></tr> <tr><td></td><td></td><td style="border: 1px solid black; padding: 2px;">7</td></tr> <tr><td></td><td></td><td style="border: 1px solid black; padding: 2px;">8</td></tr> </table> | <code>ToS</code> | 1 | 1 |  |  | 2 |  |  | 3 |  |  | 4 |  |  | 5 |  |  | 6 |  |  | 7 |  |  | 8 | <code>ToS</code> | 1 | 1 |  |  | 2 |  |  | 3 |  |  | 4 |  |  | 5 |  |  | 6 |  |  | 7 |  |  | 8 |
| <code>D</code> = 20                                                                                                                                                                                                                                                                                                                                                                                                                                                                                                                                                                                                                                                                                                                                                                                                                                                                                                                                                                                                                                                                                                                                                                                                                                                                                                                                                                                                                                                                                                                                                                                                                                                                                                                                                                                                                                                                                                                                                                         | <code>ToS</code>    | 2                |   |  |  |   |  |  |   |  |  |   |  |  |   |  |  |   |  |  |   |  |  |   |  |  |   |                  |    |   |  |  |   |  |  |   |  |  |   |  |  |   |  |  |   |  |  |   |  |  |   |  |  |   |                                                                                                                                                                                                                                                                                                                                                                                                                                                                                                                                                                                                                                                                                                                                                                                                                                                                                                                                                                                                                                                                                                                                                                                                                                                                                                                                                                                                                                                                                                                                                                                                                     |                  |   |   |  |  |   |  |  |   |  |  |   |  |  |   |  |  |   |  |  |   |                  |   |   |  |  |   |  |  |   |  |  |   |  |  |   |  |  |   |  |  |   |                                                                                                                                                                                                                                                                                                                                                                                                                                                                                                                                                                                                                                                                                                                                                                                                                                                                                                                                                                                                                                                                                                                                                                                                                                                                                                                                                                                                                                                                                                                                                                                                                                                                                                                                                                                                |                  |   |   |  |  |   |  |  |   |  |  |   |  |  |   |  |  |   |  |  |   |  |  |   |                  |   |   |  |  |   |  |  |   |  |  |   |  |  |   |  |  |   |  |  |   |  |  |   |
|                                                                                                                                                                                                                                                                                                                                                                                                                                                                                                                                                                                                                                                                                                                                                                                                                                                                                                                                                                                                                                                                                                                                                                                                                                                                                                                                                                                                                                                                                                                                                                                                                                                                                                                                                                                                                                                                                                                                                                                             |                     | 0                |   |  |  |   |  |  |   |  |  |   |  |  |   |  |  |   |  |  |   |  |  |   |  |  |   |                  |    |   |  |  |   |  |  |   |  |  |   |  |  |   |  |  |   |  |  |   |  |  |   |  |  |   |                                                                                                                                                                                                                                                                                                                                                                                                                                                                                                                                                                                                                                                                                                                                                                                                                                                                                                                                                                                                                                                                                                                                                                                                                                                                                                                                                                                                                                                                                                                                                                                                                     |                  |   |   |  |  |   |  |  |   |  |  |   |  |  |   |  |  |   |  |  |   |                  |   |   |  |  |   |  |  |   |  |  |   |  |  |   |  |  |   |  |  |   |                                                                                                                                                                                                                                                                                                                                                                                                                                                                                                                                                                                                                                                                                                                                                                                                                                                                                                                                                                                                                                                                                                                                                                                                                                                                                                                                                                                                                                                                                                                                                                                                                                                                                                                                                                                                |                  |   |   |  |  |   |  |  |   |  |  |   |  |  |   |  |  |   |  |  |   |  |  |   |                  |   |   |  |  |   |  |  |   |  |  |   |  |  |   |  |  |   |  |  |   |  |  |   |
|                                                                                                                                                                                                                                                                                                                                                                                                                                                                                                                                                                                                                                                                                                                                                                                                                                                                                                                                                                                                                                                                                                                                                                                                                                                                                                                                                                                                                                                                                                                                                                                                                                                                                                                                                                                                                                                                                                                                                                                             |                     | 0                |   |  |  |   |  |  |   |  |  |   |  |  |   |  |  |   |  |  |   |  |  |   |  |  |   |                  |    |   |  |  |   |  |  |   |  |  |   |  |  |   |  |  |   |  |  |   |  |  |   |  |  |   |                                                                                                                                                                                                                                                                                                                                                                                                                                                                                                                                                                                                                                                                                                                                                                                                                                                                                                                                                                                                                                                                                                                                                                                                                                                                                                                                                                                                                                                                                                                                                                                                                     |                  |   |   |  |  |   |  |  |   |  |  |   |  |  |   |  |  |   |  |  |   |                  |   |   |  |  |   |  |  |   |  |  |   |  |  |   |  |  |   |  |  |   |                                                                                                                                                                                                                                                                                                                                                                                                                                                                                                                                                                                                                                                                                                                                                                                                                                                                                                                                                                                                                                                                                                                                                                                                                                                                                                                                                                                                                                                                                                                                                                                                                                                                                                                                                                                                |                  |   |   |  |  |   |  |  |   |  |  |   |  |  |   |  |  |   |  |  |   |  |  |   |                  |   |   |  |  |   |  |  |   |  |  |   |  |  |   |  |  |   |  |  |   |  |  |   |
|                                                                                                                                                                                                                                                                                                                                                                                                                                                                                                                                                                                                                                                                                                                                                                                                                                                                                                                                                                                                                                                                                                                                                                                                                                                                                                                                                                                                                                                                                                                                                                                                                                                                                                                                                                                                                                                                                                                                                                                             |                     | 0                |   |  |  |   |  |  |   |  |  |   |  |  |   |  |  |   |  |  |   |  |  |   |  |  |   |                  |    |   |  |  |   |  |  |   |  |  |   |  |  |   |  |  |   |  |  |   |  |  |   |  |  |   |                                                                                                                                                                                                                                                                                                                                                                                                                                                                                                                                                                                                                                                                                                                                                                                                                                                                                                                                                                                                                                                                                                                                                                                                                                                                                                                                                                                                                                                                                                                                                                                                                     |                  |   |   |  |  |   |  |  |   |  |  |   |  |  |   |  |  |   |  |  |   |                  |   |   |  |  |   |  |  |   |  |  |   |  |  |   |  |  |   |  |  |   |                                                                                                                                                                                                                                                                                                                                                                                                                                                                                                                                                                                                                                                                                                                                                                                                                                                                                                                                                                                                                                                                                                                                                                                                                                                                                                                                                                                                                                                                                                                                                                                                                                                                                                                                                                                                |                  |   |   |  |  |   |  |  |   |  |  |   |  |  |   |  |  |   |  |  |   |  |  |   |                  |   |   |  |  |   |  |  |   |  |  |   |  |  |   |  |  |   |  |  |   |  |  |   |
|                                                                                                                                                                                                                                                                                                                                                                                                                                                                                                                                                                                                                                                                                                                                                                                                                                                                                                                                                                                                                                                                                                                                                                                                                                                                                                                                                                                                                                                                                                                                                                                                                                                                                                                                                                                                                                                                                                                                                                                             |                     | 0                |   |  |  |   |  |  |   |  |  |   |  |  |   |  |  |   |  |  |   |  |  |   |  |  |   |                  |    |   |  |  |   |  |  |   |  |  |   |  |  |   |  |  |   |  |  |   |  |  |   |  |  |   |                                                                                                                                                                                                                                                                                                                                                                                                                                                                                                                                                                                                                                                                                                                                                                                                                                                                                                                                                                                                                                                                                                                                                                                                                                                                                                                                                                                                                                                                                                                                                                                                                     |                  |   |   |  |  |   |  |  |   |  |  |   |  |  |   |  |  |   |  |  |   |                  |   |   |  |  |   |  |  |   |  |  |   |  |  |   |  |  |   |  |  |   |                                                                                                                                                                                                                                                                                                                                                                                                                                                                                                                                                                                                                                                                                                                                                                                                                                                                                                                                                                                                                                                                                                                                                                                                                                                                                                                                                                                                                                                                                                                                                                                                                                                                                                                                                                                                |                  |   |   |  |  |   |  |  |   |  |  |   |  |  |   |  |  |   |  |  |   |  |  |   |                  |   |   |  |  |   |  |  |   |  |  |   |  |  |   |  |  |   |  |  |   |  |  |   |
|                                                                                                                                                                                                                                                                                                                                                                                                                                                                                                                                                                                                                                                                                                                                                                                                                                                                                                                                                                                                                                                                                                                                                                                                                                                                                                                                                                                                                                                                                                                                                                                                                                                                                                                                                                                                                                                                                                                                                                                             |                     | 0                |   |  |  |   |  |  |   |  |  |   |  |  |   |  |  |   |  |  |   |  |  |   |  |  |   |                  |    |   |  |  |   |  |  |   |  |  |   |  |  |   |  |  |   |  |  |   |  |  |   |  |  |   |                                                                                                                                                                                                                                                                                                                                                                                                                                                                                                                                                                                                                                                                                                                                                                                                                                                                                                                                                                                                                                                                                                                                                                                                                                                                                                                                                                                                                                                                                                                                                                                                                     |                  |   |   |  |  |   |  |  |   |  |  |   |  |  |   |  |  |   |  |  |   |                  |   |   |  |  |   |  |  |   |  |  |   |  |  |   |  |  |   |  |  |   |                                                                                                                                                                                                                                                                                                                                                                                                                                                                                                                                                                                                                                                                                                                                                                                                                                                                                                                                                                                                                                                                                                                                                                                                                                                                                                                                                                                                                                                                                                                                                                                                                                                                                                                                                                                                |                  |   |   |  |  |   |  |  |   |  |  |   |  |  |   |  |  |   |  |  |   |  |  |   |                  |   |   |  |  |   |  |  |   |  |  |   |  |  |   |  |  |   |  |  |   |  |  |   |
|                                                                                                                                                                                                                                                                                                                                                                                                                                                                                                                                                                                                                                                                                                                                                                                                                                                                                                                                                                                                                                                                                                                                                                                                                                                                                                                                                                                                                                                                                                                                                                                                                                                                                                                                                                                                                                                                                                                                                                                             |                     | 0                |   |  |  |   |  |  |   |  |  |   |  |  |   |  |  |   |  |  |   |  |  |   |  |  |   |                  |    |   |  |  |   |  |  |   |  |  |   |  |  |   |  |  |   |  |  |   |  |  |   |  |  |   |                                                                                                                                                                                                                                                                                                                                                                                                                                                                                                                                                                                                                                                                                                                                                                                                                                                                                                                                                                                                                                                                                                                                                                                                                                                                                                                                                                                                                                                                                                                                                                                                                     |                  |   |   |  |  |   |  |  |   |  |  |   |  |  |   |  |  |   |  |  |   |                  |   |   |  |  |   |  |  |   |  |  |   |  |  |   |  |  |   |  |  |   |                                                                                                                                                                                                                                                                                                                                                                                                                                                                                                                                                                                                                                                                                                                                                                                                                                                                                                                                                                                                                                                                                                                                                                                                                                                                                                                                                                                                                                                                                                                                                                                                                                                                                                                                                                                                |                  |   |   |  |  |   |  |  |   |  |  |   |  |  |   |  |  |   |  |  |   |  |  |   |                  |   |   |  |  |   |  |  |   |  |  |   |  |  |   |  |  |   |  |  |   |  |  |   |
|                                                                                                                                                                                                                                                                                                                                                                                                                                                                                                                                                                                                                                                                                                                                                                                                                                                                                                                                                                                                                                                                                                                                                                                                                                                                                                                                                                                                                                                                                                                                                                                                                                                                                                                                                                                                                                                                                                                                                                                             |                     | 0                |   |  |  |   |  |  |   |  |  |   |  |  |   |  |  |   |  |  |   |  |  |   |  |  |   |                  |    |   |  |  |   |  |  |   |  |  |   |  |  |   |  |  |   |  |  |   |  |  |   |  |  |   |                                                                                                                                                                                                                                                                                                                                                                                                                                                                                                                                                                                                                                                                                                                                                                                                                                                                                                                                                                                                                                                                                                                                                                                                                                                                                                                                                                                                                                                                                                                                                                                                                     |                  |   |   |  |  |   |  |  |   |  |  |   |  |  |   |  |  |   |  |  |   |                  |   |   |  |  |   |  |  |   |  |  |   |  |  |   |  |  |   |  |  |   |                                                                                                                                                                                                                                                                                                                                                                                                                                                                                                                                                                                                                                                                                                                                                                                                                                                                                                                                                                                                                                                                                                                                                                                                                                                                                                                                                                                                                                                                                                                                                                                                                                                                                                                                                                                                |                  |   |   |  |  |   |  |  |   |  |  |   |  |  |   |  |  |   |  |  |   |  |  |   |                  |   |   |  |  |   |  |  |   |  |  |   |  |  |   |  |  |   |  |  |   |  |  |   |
|                                                                                                                                                                                                                                                                                                                                                                                                                                                                                                                                                                                                                                                                                                                                                                                                                                                                                                                                                                                                                                                                                                                                                                                                                                                                                                                                                                                                                                                                                                                                                                                                                                                                                                                                                                                                                                                                                                                                                                                             |                     | 0                |   |  |  |   |  |  |   |  |  |   |  |  |   |  |  |   |  |  |   |  |  |   |  |  |   |                  |    |   |  |  |   |  |  |   |  |  |   |  |  |   |  |  |   |  |  |   |  |  |   |  |  |   |                                                                                                                                                                                                                                                                                                                                                                                                                                                                                                                                                                                                                                                                                                                                                                                                                                                                                                                                                                                                                                                                                                                                                                                                                                                                                                                                                                                                                                                                                                                                                                                                                     |                  |   |   |  |  |   |  |  |   |  |  |   |  |  |   |  |  |   |  |  |   |                  |   |   |  |  |   |  |  |   |  |  |   |  |  |   |  |  |   |  |  |   |                                                                                                                                                                                                                                                                                                                                                                                                                                                                                                                                                                                                                                                                                                                                                                                                                                                                                                                                                                                                                                                                                                                                                                                                                                                                                                                                                                                                                                                                                                                                                                                                                                                                                                                                                                                                |                  |   |   |  |  |   |  |  |   |  |  |   |  |  |   |  |  |   |  |  |   |  |  |   |                  |   |   |  |  |   |  |  |   |  |  |   |  |  |   |  |  |   |  |  |   |  |  |   |
| <code>ToS</code>                                                                                                                                                                                                                                                                                                                                                                                                                                                                                                                                                                                                                                                                                                                                                                                                                                                                                                                                                                                                                                                                                                                                                                                                                                                                                                                                                                                                                                                                                                                                                                                                                                                                                                                                                                                                                                                                                                                                                                            | 20                  | 2                |   |  |  |   |  |  |   |  |  |   |  |  |   |  |  |   |  |  |   |  |  |   |  |  |   |                  |    |   |  |  |   |  |  |   |  |  |   |  |  |   |  |  |   |  |  |   |  |  |   |  |  |   |                                                                                                                                                                                                                                                                                                                                                                                                                                                                                                                                                                                                                                                                                                                                                                                                                                                                                                                                                                                                                                                                                                                                                                                                                                                                                                                                                                                                                                                                                                                                                                                                                     |                  |   |   |  |  |   |  |  |   |  |  |   |  |  |   |  |  |   |  |  |   |                  |   |   |  |  |   |  |  |   |  |  |   |  |  |   |  |  |   |  |  |   |                                                                                                                                                                                                                                                                                                                                                                                                                                                                                                                                                                                                                                                                                                                                                                                                                                                                                                                                                                                                                                                                                                                                                                                                                                                                                                                                                                                                                                                                                                                                                                                                                                                                                                                                                                                                |                  |   |   |  |  |   |  |  |   |  |  |   |  |  |   |  |  |   |  |  |   |  |  |   |                  |   |   |  |  |   |  |  |   |  |  |   |  |  |   |  |  |   |  |  |   |  |  |   |
|                                                                                                                                                                                                                                                                                                                                                                                                                                                                                                                                                                                                                                                                                                                                                                                                                                                                                                                                                                                                                                                                                                                                                                                                                                                                                                                                                                                                                                                                                                                                                                                                                                                                                                                                                                                                                                                                                                                                                                                             |                     | 2                |   |  |  |   |  |  |   |  |  |   |  |  |   |  |  |   |  |  |   |  |  |   |  |  |   |                  |    |   |  |  |   |  |  |   |  |  |   |  |  |   |  |  |   |  |  |   |  |  |   |  |  |   |                                                                                                                                                                                                                                                                                                                                                                                                                                                                                                                                                                                                                                                                                                                                                                                                                                                                                                                                                                                                                                                                                                                                                                                                                                                                                                                                                                                                                                                                                                                                                                                                                     |                  |   |   |  |  |   |  |  |   |  |  |   |  |  |   |  |  |   |  |  |   |                  |   |   |  |  |   |  |  |   |  |  |   |  |  |   |  |  |   |  |  |   |                                                                                                                                                                                                                                                                                                                                                                                                                                                                                                                                                                                                                                                                                                                                                                                                                                                                                                                                                                                                                                                                                                                                                                                                                                                                                                                                                                                                                                                                                                                                                                                                                                                                                                                                                                                                |                  |   |   |  |  |   |  |  |   |  |  |   |  |  |   |  |  |   |  |  |   |  |  |   |                  |   |   |  |  |   |  |  |   |  |  |   |  |  |   |  |  |   |  |  |   |  |  |   |
|                                                                                                                                                                                                                                                                                                                                                                                                                                                                                                                                                                                                                                                                                                                                                                                                                                                                                                                                                                                                                                                                                                                                                                                                                                                                                                                                                                                                                                                                                                                                                                                                                                                                                                                                                                                                                                                                                                                                                                                             |                     | 0                |   |  |  |   |  |  |   |  |  |   |  |  |   |  |  |   |  |  |   |  |  |   |  |  |   |                  |    |   |  |  |   |  |  |   |  |  |   |  |  |   |  |  |   |  |  |   |  |  |   |  |  |   |                                                                                                                                                                                                                                                                                                                                                                                                                                                                                                                                                                                                                                                                                                                                                                                                                                                                                                                                                                                                                                                                                                                                                                                                                                                                                                                                                                                                                                                                                                                                                                                                                     |                  |   |   |  |  |   |  |  |   |  |  |   |  |  |   |  |  |   |  |  |   |                  |   |   |  |  |   |  |  |   |  |  |   |  |  |   |  |  |   |  |  |   |                                                                                                                                                                                                                                                                                                                                                                                                                                                                                                                                                                                                                                                                                                                                                                                                                                                                                                                                                                                                                                                                                                                                                                                                                                                                                                                                                                                                                                                                                                                                                                                                                                                                                                                                                                                                |                  |   |   |  |  |   |  |  |   |  |  |   |  |  |   |  |  |   |  |  |   |  |  |   |                  |   |   |  |  |   |  |  |   |  |  |   |  |  |   |  |  |   |  |  |   |  |  |   |
|                                                                                                                                                                                                                                                                                                                                                                                                                                                                                                                                                                                                                                                                                                                                                                                                                                                                                                                                                                                                                                                                                                                                                                                                                                                                                                                                                                                                                                                                                                                                                                                                                                                                                                                                                                                                                                                                                                                                                                                             |                     | 0                |   |  |  |   |  |  |   |  |  |   |  |  |   |  |  |   |  |  |   |  |  |   |  |  |   |                  |    |   |  |  |   |  |  |   |  |  |   |  |  |   |  |  |   |  |  |   |  |  |   |  |  |   |                                                                                                                                                                                                                                                                                                                                                                                                                                                                                                                                                                                                                                                                                                                                                                                                                                                                                                                                                                                                                                                                                                                                                                                                                                                                                                                                                                                                                                                                                                                                                                                                                     |                  |   |   |  |  |   |  |  |   |  |  |   |  |  |   |  |  |   |  |  |   |                  |   |   |  |  |   |  |  |   |  |  |   |  |  |   |  |  |   |  |  |   |                                                                                                                                                                                                                                                                                                                                                                                                                                                                                                                                                                                                                                                                                                                                                                                                                                                                                                                                                                                                                                                                                                                                                                                                                                                                                                                                                                                                                                                                                                                                                                                                                                                                                                                                                                                                |                  |   |   |  |  |   |  |  |   |  |  |   |  |  |   |  |  |   |  |  |   |  |  |   |                  |   |   |  |  |   |  |  |   |  |  |   |  |  |   |  |  |   |  |  |   |  |  |   |
|                                                                                                                                                                                                                                                                                                                                                                                                                                                                                                                                                                                                                                                                                                                                                                                                                                                                                                                                                                                                                                                                                                                                                                                                                                                                                                                                                                                                                                                                                                                                                                                                                                                                                                                                                                                                                                                                                                                                                                                             |                     | 0                |   |  |  |   |  |  |   |  |  |   |  |  |   |  |  |   |  |  |   |  |  |   |  |  |   |                  |    |   |  |  |   |  |  |   |  |  |   |  |  |   |  |  |   |  |  |   |  |  |   |  |  |   |                                                                                                                                                                                                                                                                                                                                                                                                                                                                                                                                                                                                                                                                                                                                                                                                                                                                                                                                                                                                                                                                                                                                                                                                                                                                                                                                                                                                                                                                                                                                                                                                                     |                  |   |   |  |  |   |  |  |   |  |  |   |  |  |   |  |  |   |  |  |   |                  |   |   |  |  |   |  |  |   |  |  |   |  |  |   |  |  |   |  |  |   |                                                                                                                                                                                                                                                                                                                                                                                                                                                                                                                                                                                                                                                                                                                                                                                                                                                                                                                                                                                                                                                                                                                                                                                                                                                                                                                                                                                                                                                                                                                                                                                                                                                                                                                                                                                                |                  |   |   |  |  |   |  |  |   |  |  |   |  |  |   |  |  |   |  |  |   |  |  |   |                  |   |   |  |  |   |  |  |   |  |  |   |  |  |   |  |  |   |  |  |   |  |  |   |
|                                                                                                                                                                                                                                                                                                                                                                                                                                                                                                                                                                                                                                                                                                                                                                                                                                                                                                                                                                                                                                                                                                                                                                                                                                                                                                                                                                                                                                                                                                                                                                                                                                                                                                                                                                                                                                                                                                                                                                                             |                     | 0                |   |  |  |   |  |  |   |  |  |   |  |  |   |  |  |   |  |  |   |  |  |   |  |  |   |                  |    |   |  |  |   |  |  |   |  |  |   |  |  |   |  |  |   |  |  |   |  |  |   |  |  |   |                                                                                                                                                                                                                                                                                                                                                                                                                                                                                                                                                                                                                                                                                                                                                                                                                                                                                                                                                                                                                                                                                                                                                                                                                                                                                                                                                                                                                                                                                                                                                                                                                     |                  |   |   |  |  |   |  |  |   |  |  |   |  |  |   |  |  |   |  |  |   |                  |   |   |  |  |   |  |  |   |  |  |   |  |  |   |  |  |   |  |  |   |                                                                                                                                                                                                                                                                                                                                                                                                                                                                                                                                                                                                                                                                                                                                                                                                                                                                                                                                                                                                                                                                                                                                                                                                                                                                                                                                                                                                                                                                                                                                                                                                                                                                                                                                                                                                |                  |   |   |  |  |   |  |  |   |  |  |   |  |  |   |  |  |   |  |  |   |  |  |   |                  |   |   |  |  |   |  |  |   |  |  |   |  |  |   |  |  |   |  |  |   |  |  |   |
|                                                                                                                                                                                                                                                                                                                                                                                                                                                                                                                                                                                                                                                                                                                                                                                                                                                                                                                                                                                                                                                                                                                                                                                                                                                                                                                                                                                                                                                                                                                                                                                                                                                                                                                                                                                                                                                                                                                                                                                             |                     | 0                |   |  |  |   |  |  |   |  |  |   |  |  |   |  |  |   |  |  |   |  |  |   |  |  |   |                  |    |   |  |  |   |  |  |   |  |  |   |  |  |   |  |  |   |  |  |   |  |  |   |  |  |   |                                                                                                                                                                                                                                                                                                                                                                                                                                                                                                                                                                                                                                                                                                                                                                                                                                                                                                                                                                                                                                                                                                                                                                                                                                                                                                                                                                                                                                                                                                                                                                                                                     |                  |   |   |  |  |   |  |  |   |  |  |   |  |  |   |  |  |   |  |  |   |                  |   |   |  |  |   |  |  |   |  |  |   |  |  |   |  |  |   |  |  |   |                                                                                                                                                                                                                                                                                                                                                                                                                                                                                                                                                                                                                                                                                                                                                                                                                                                                                                                                                                                                                                                                                                                                                                                                                                                                                                                                                                                                                                                                                                                                                                                                                                                                                                                                                                                                |                  |   |   |  |  |   |  |  |   |  |  |   |  |  |   |  |  |   |  |  |   |  |  |   |                  |   |   |  |  |   |  |  |   |  |  |   |  |  |   |  |  |   |  |  |   |  |  |   |
|                                                                                                                                                                                                                                                                                                                                                                                                                                                                                                                                                                                                                                                                                                                                                                                                                                                                                                                                                                                                                                                                                                                                                                                                                                                                                                                                                                                                                                                                                                                                                                                                                                                                                                                                                                                                                                                                                                                                                                                             |                     | 0                |   |  |  |   |  |  |   |  |  |   |  |  |   |  |  |   |  |  |   |  |  |   |  |  |   |                  |    |   |  |  |   |  |  |   |  |  |   |  |  |   |  |  |   |  |  |   |  |  |   |  |  |   |                                                                                                                                                                                                                                                                                                                                                                                                                                                                                                                                                                                                                                                                                                                                                                                                                                                                                                                                                                                                                                                                                                                                                                                                                                                                                                                                                                                                                                                                                                                                                                                                                     |                  |   |   |  |  |   |  |  |   |  |  |   |  |  |   |  |  |   |  |  |   |                  |   |   |  |  |   |  |  |   |  |  |   |  |  |   |  |  |   |  |  |   |                                                                                                                                                                                                                                                                                                                                                                                                                                                                                                                                                                                                                                                                                                                                                                                                                                                                                                                                                                                                                                                                                                                                                                                                                                                                                                                                                                                                                                                                                                                                                                                                                                                                                                                                                                                                |                  |   |   |  |  |   |  |  |   |  |  |   |  |  |   |  |  |   |  |  |   |  |  |   |                  |   |   |  |  |   |  |  |   |  |  |   |  |  |   |  |  |   |  |  |   |  |  |   |
|                                                                                                                                                                                                                                                                                                                                                                                                                                                                                                                                                                                                                                                                                                                                                                                                                                                                                                                                                                                                                                                                                                                                                                                                                                                                                                                                                                                                                                                                                                                                                                                                                                                                                                                                                                                                                                                                                                                                                                                             |                     | 0                |   |  |  |   |  |  |   |  |  |   |  |  |   |  |  |   |  |  |   |  |  |   |  |  |   |                  |    |   |  |  |   |  |  |   |  |  |   |  |  |   |  |  |   |  |  |   |  |  |   |  |  |   |                                                                                                                                                                                                                                                                                                                                                                                                                                                                                                                                                                                                                                                                                                                                                                                                                                                                                                                                                                                                                                                                                                                                                                                                                                                                                                                                                                                                                                                                                                                                                                                                                     |                  |   |   |  |  |   |  |  |   |  |  |   |  |  |   |  |  |   |  |  |   |                  |   |   |  |  |   |  |  |   |  |  |   |  |  |   |  |  |   |  |  |   |                                                                                                                                                                                                                                                                                                                                                                                                                                                                                                                                                                                                                                                                                                                                                                                                                                                                                                                                                                                                                                                                                                                                                                                                                                                                                                                                                                                                                                                                                                                                                                                                                                                                                                                                                                                                |                  |   |   |  |  |   |  |  |   |  |  |   |  |  |   |  |  |   |  |  |   |  |  |   |                  |   |   |  |  |   |  |  |   |  |  |   |  |  |   |  |  |   |  |  |   |  |  |   |
| <code>ToS</code>                                                                                                                                                                                                                                                                                                                                                                                                                                                                                                                                                                                                                                                                                                                                                                                                                                                                                                                                                                                                                                                                                                                                                                                                                                                                                                                                                                                                                                                                                                                                                                                                                                                                                                                                                                                                                                                                                                                                                                            | 1                   | 2                |   |  |  |   |  |  |   |  |  |   |  |  |   |  |  |   |  |  |   |  |  |   |  |  |   |                  |    |   |  |  |   |  |  |   |  |  |   |  |  |   |  |  |   |  |  |   |  |  |   |  |  |   |                                                                                                                                                                                                                                                                                                                                                                                                                                                                                                                                                                                                                                                                                                                                                                                                                                                                                                                                                                                                                                                                                                                                                                                                                                                                                                                                                                                                                                                                                                                                                                                                                     |                  |   |   |  |  |   |  |  |   |  |  |   |  |  |   |  |  |   |  |  |   |                  |   |   |  |  |   |  |  |   |  |  |   |  |  |   |  |  |   |  |  |   |                                                                                                                                                                                                                                                                                                                                                                                                                                                                                                                                                                                                                                                                                                                                                                                                                                                                                                                                                                                                                                                                                                                                                                                                                                                                                                                                                                                                                                                                                                                                                                                                                                                                                                                                                                                                |                  |   |   |  |  |   |  |  |   |  |  |   |  |  |   |  |  |   |  |  |   |  |  |   |                  |   |   |  |  |   |  |  |   |  |  |   |  |  |   |  |  |   |  |  |   |  |  |   |
|                                                                                                                                                                                                                                                                                                                                                                                                                                                                                                                                                                                                                                                                                                                                                                                                                                                                                                                                                                                                                                                                                                                                                                                                                                                                                                                                                                                                                                                                                                                                                                                                                                                                                                                                                                                                                                                                                                                                                                                             |                     | 3                |   |  |  |   |  |  |   |  |  |   |  |  |   |  |  |   |  |  |   |  |  |   |  |  |   |                  |    |   |  |  |   |  |  |   |  |  |   |  |  |   |  |  |   |  |  |   |  |  |   |  |  |   |                                                                                                                                                                                                                                                                                                                                                                                                                                                                                                                                                                                                                                                                                                                                                                                                                                                                                                                                                                                                                                                                                                                                                                                                                                                                                                                                                                                                                                                                                                                                                                                                                     |                  |   |   |  |  |   |  |  |   |  |  |   |  |  |   |  |  |   |  |  |   |                  |   |   |  |  |   |  |  |   |  |  |   |  |  |   |  |  |   |  |  |   |                                                                                                                                                                                                                                                                                                                                                                                                                                                                                                                                                                                                                                                                                                                                                                                                                                                                                                                                                                                                                                                                                                                                                                                                                                                                                                                                                                                                                                                                                                                                                                                                                                                                                                                                                                                                |                  |   |   |  |  |   |  |  |   |  |  |   |  |  |   |  |  |   |  |  |   |  |  |   |                  |   |   |  |  |   |  |  |   |  |  |   |  |  |   |  |  |   |  |  |   |  |  |   |
|                                                                                                                                                                                                                                                                                                                                                                                                                                                                                                                                                                                                                                                                                                                                                                                                                                                                                                                                                                                                                                                                                                                                                                                                                                                                                                                                                                                                                                                                                                                                                                                                                                                                                                                                                                                                                                                                                                                                                                                             |                     | 4                |   |  |  |   |  |  |   |  |  |   |  |  |   |  |  |   |  |  |   |  |  |   |  |  |   |                  |    |   |  |  |   |  |  |   |  |  |   |  |  |   |  |  |   |  |  |   |  |  |   |  |  |   |                                                                                                                                                                                                                                                                                                                                                                                                                                                                                                                                                                                                                                                                                                                                                                                                                                                                                                                                                                                                                                                                                                                                                                                                                                                                                                                                                                                                                                                                                                                                                                                                                     |                  |   |   |  |  |   |  |  |   |  |  |   |  |  |   |  |  |   |  |  |   |                  |   |   |  |  |   |  |  |   |  |  |   |  |  |   |  |  |   |  |  |   |                                                                                                                                                                                                                                                                                                                                                                                                                                                                                                                                                                                                                                                                                                                                                                                                                                                                                                                                                                                                                                                                                                                                                                                                                                                                                                                                                                                                                                                                                                                                                                                                                                                                                                                                                                                                |                  |   |   |  |  |   |  |  |   |  |  |   |  |  |   |  |  |   |  |  |   |  |  |   |                  |   |   |  |  |   |  |  |   |  |  |   |  |  |   |  |  |   |  |  |   |  |  |   |
|                                                                                                                                                                                                                                                                                                                                                                                                                                                                                                                                                                                                                                                                                                                                                                                                                                                                                                                                                                                                                                                                                                                                                                                                                                                                                                                                                                                                                                                                                                                                                                                                                                                                                                                                                                                                                                                                                                                                                                                             |                     | 5                |   |  |  |   |  |  |   |  |  |   |  |  |   |  |  |   |  |  |   |  |  |   |  |  |   |                  |    |   |  |  |   |  |  |   |  |  |   |  |  |   |  |  |   |  |  |   |  |  |   |  |  |   |                                                                                                                                                                                                                                                                                                                                                                                                                                                                                                                                                                                                                                                                                                                                                                                                                                                                                                                                                                                                                                                                                                                                                                                                                                                                                                                                                                                                                                                                                                                                                                                                                     |                  |   |   |  |  |   |  |  |   |  |  |   |  |  |   |  |  |   |  |  |   |                  |   |   |  |  |   |  |  |   |  |  |   |  |  |   |  |  |   |  |  |   |                                                                                                                                                                                                                                                                                                                                                                                                                                                                                                                                                                                                                                                                                                                                                                                                                                                                                                                                                                                                                                                                                                                                                                                                                                                                                                                                                                                                                                                                                                                                                                                                                                                                                                                                                                                                |                  |   |   |  |  |   |  |  |   |  |  |   |  |  |   |  |  |   |  |  |   |  |  |   |                  |   |   |  |  |   |  |  |   |  |  |   |  |  |   |  |  |   |  |  |   |  |  |   |
|                                                                                                                                                                                                                                                                                                                                                                                                                                                                                                                                                                                                                                                                                                                                                                                                                                                                                                                                                                                                                                                                                                                                                                                                                                                                                                                                                                                                                                                                                                                                                                                                                                                                                                                                                                                                                                                                                                                                                                                             |                     | 6                |   |  |  |   |  |  |   |  |  |   |  |  |   |  |  |   |  |  |   |  |  |   |  |  |   |                  |    |   |  |  |   |  |  |   |  |  |   |  |  |   |  |  |   |  |  |   |  |  |   |  |  |   |                                                                                                                                                                                                                                                                                                                                                                                                                                                                                                                                                                                                                                                                                                                                                                                                                                                                                                                                                                                                                                                                                                                                                                                                                                                                                                                                                                                                                                                                                                                                                                                                                     |                  |   |   |  |  |   |  |  |   |  |  |   |  |  |   |  |  |   |  |  |   |                  |   |   |  |  |   |  |  |   |  |  |   |  |  |   |  |  |   |  |  |   |                                                                                                                                                                                                                                                                                                                                                                                                                                                                                                                                                                                                                                                                                                                                                                                                                                                                                                                                                                                                                                                                                                                                                                                                                                                                                                                                                                                                                                                                                                                                                                                                                                                                                                                                                                                                |                  |   |   |  |  |   |  |  |   |  |  |   |  |  |   |  |  |   |  |  |   |  |  |   |                  |   |   |  |  |   |  |  |   |  |  |   |  |  |   |  |  |   |  |  |   |  |  |   |
|                                                                                                                                                                                                                                                                                                                                                                                                                                                                                                                                                                                                                                                                                                                                                                                                                                                                                                                                                                                                                                                                                                                                                                                                                                                                                                                                                                                                                                                                                                                                                                                                                                                                                                                                                                                                                                                                                                                                                                                             |                     | 7                |   |  |  |   |  |  |   |  |  |   |  |  |   |  |  |   |  |  |   |  |  |   |  |  |   |                  |    |   |  |  |   |  |  |   |  |  |   |  |  |   |  |  |   |  |  |   |  |  |   |  |  |   |                                                                                                                                                                                                                                                                                                                                                                                                                                                                                                                                                                                                                                                                                                                                                                                                                                                                                                                                                                                                                                                                                                                                                                                                                                                                                                                                                                                                                                                                                                                                                                                                                     |                  |   |   |  |  |   |  |  |   |  |  |   |  |  |   |  |  |   |  |  |   |                  |   |   |  |  |   |  |  |   |  |  |   |  |  |   |  |  |   |  |  |   |                                                                                                                                                                                                                                                                                                                                                                                                                                                                                                                                                                                                                                                                                                                                                                                                                                                                                                                                                                                                                                                                                                                                                                                                                                                                                                                                                                                                                                                                                                                                                                                                                                                                                                                                                                                                |                  |   |   |  |  |   |  |  |   |  |  |   |  |  |   |  |  |   |  |  |   |  |  |   |                  |   |   |  |  |   |  |  |   |  |  |   |  |  |   |  |  |   |  |  |   |  |  |   |
|                                                                                                                                                                                                                                                                                                                                                                                                                                                                                                                                                                                                                                                                                                                                                                                                                                                                                                                                                                                                                                                                                                                                                                                                                                                                                                                                                                                                                                                                                                                                                                                                                                                                                                                                                                                                                                                                                                                                                                                             |                     | 8                |   |  |  |   |  |  |   |  |  |   |  |  |   |  |  |   |  |  |   |  |  |   |  |  |   |                  |    |   |  |  |   |  |  |   |  |  |   |  |  |   |  |  |   |  |  |   |  |  |   |  |  |   |                                                                                                                                                                                                                                                                                                                                                                                                                                                                                                                                                                                                                                                                                                                                                                                                                                                                                                                                                                                                                                                                                                                                                                                                                                                                                                                                                                                                                                                                                                                                                                                                                     |                  |   |   |  |  |   |  |  |   |  |  |   |  |  |   |  |  |   |  |  |   |                  |   |   |  |  |   |  |  |   |  |  |   |  |  |   |  |  |   |  |  |   |                                                                                                                                                                                                                                                                                                                                                                                                                                                                                                                                                                                                                                                                                                                                                                                                                                                                                                                                                                                                                                                                                                                                                                                                                                                                                                                                                                                                                                                                                                                                                                                                                                                                                                                                                                                                |                  |   |   |  |  |   |  |  |   |  |  |   |  |  |   |  |  |   |  |  |   |  |  |   |                  |   |   |  |  |   |  |  |   |  |  |   |  |  |   |  |  |   |  |  |   |  |  |   |
| <code>ToS</code>                                                                                                                                                                                                                                                                                                                                                                                                                                                                                                                                                                                                                                                                                                                                                                                                                                                                                                                                                                                                                                                                                                                                                                                                                                                                                                                                                                                                                                                                                                                                                                                                                                                                                                                                                                                                                                                                                                                                                                            | 2                   | 3                |   |  |  |   |  |  |   |  |  |   |  |  |   |  |  |   |  |  |   |  |  |   |  |  |   |                  |    |   |  |  |   |  |  |   |  |  |   |  |  |   |  |  |   |  |  |   |  |  |   |  |  |   |                                                                                                                                                                                                                                                                                                                                                                                                                                                                                                                                                                                                                                                                                                                                                                                                                                                                                                                                                                                                                                                                                                                                                                                                                                                                                                                                                                                                                                                                                                                                                                                                                     |                  |   |   |  |  |   |  |  |   |  |  |   |  |  |   |  |  |   |  |  |   |                  |   |   |  |  |   |  |  |   |  |  |   |  |  |   |  |  |   |  |  |   |                                                                                                                                                                                                                                                                                                                                                                                                                                                                                                                                                                                                                                                                                                                                                                                                                                                                                                                                                                                                                                                                                                                                                                                                                                                                                                                                                                                                                                                                                                                                                                                                                                                                                                                                                                                                |                  |   |   |  |  |   |  |  |   |  |  |   |  |  |   |  |  |   |  |  |   |  |  |   |                  |   |   |  |  |   |  |  |   |  |  |   |  |  |   |  |  |   |  |  |   |  |  |   |
|                                                                                                                                                                                                                                                                                                                                                                                                                                                                                                                                                                                                                                                                                                                                                                                                                                                                                                                                                                                                                                                                                                                                                                                                                                                                                                                                                                                                                                                                                                                                                                                                                                                                                                                                                                                                                                                                                                                                                                                             |                     | 4                |   |  |  |   |  |  |   |  |  |   |  |  |   |  |  |   |  |  |   |  |  |   |  |  |   |                  |    |   |  |  |   |  |  |   |  |  |   |  |  |   |  |  |   |  |  |   |  |  |   |  |  |   |                                                                                                                                                                                                                                                                                                                                                                                                                                                                                                                                                                                                                                                                                                                                                                                                                                                                                                                                                                                                                                                                                                                                                                                                                                                                                                                                                                                                                                                                                                                                                                                                                     |                  |   |   |  |  |   |  |  |   |  |  |   |  |  |   |  |  |   |  |  |   |                  |   |   |  |  |   |  |  |   |  |  |   |  |  |   |  |  |   |  |  |   |                                                                                                                                                                                                                                                                                                                                                                                                                                                                                                                                                                                                                                                                                                                                                                                                                                                                                                                                                                                                                                                                                                                                                                                                                                                                                                                                                                                                                                                                                                                                                                                                                                                                                                                                                                                                |                  |   |   |  |  |   |  |  |   |  |  |   |  |  |   |  |  |   |  |  |   |  |  |   |                  |   |   |  |  |   |  |  |   |  |  |   |  |  |   |  |  |   |  |  |   |  |  |   |
|                                                                                                                                                                                                                                                                                                                                                                                                                                                                                                                                                                                                                                                                                                                                                                                                                                                                                                                                                                                                                                                                                                                                                                                                                                                                                                                                                                                                                                                                                                                                                                                                                                                                                                                                                                                                                                                                                                                                                                                             |                     | 5                |   |  |  |   |  |  |   |  |  |   |  |  |   |  |  |   |  |  |   |  |  |   |  |  |   |                  |    |   |  |  |   |  |  |   |  |  |   |  |  |   |  |  |   |  |  |   |  |  |   |  |  |   |                                                                                                                                                                                                                                                                                                                                                                                                                                                                                                                                                                                                                                                                                                                                                                                                                                                                                                                                                                                                                                                                                                                                                                                                                                                                                                                                                                                                                                                                                                                                                                                                                     |                  |   |   |  |  |   |  |  |   |  |  |   |  |  |   |  |  |   |  |  |   |                  |   |   |  |  |   |  |  |   |  |  |   |  |  |   |  |  |   |  |  |   |                                                                                                                                                                                                                                                                                                                                                                                                                                                                                                                                                                                                                                                                                                                                                                                                                                                                                                                                                                                                                                                                                                                                                                                                                                                                                                                                                                                                                                                                                                                                                                                                                                                                                                                                                                                                |                  |   |   |  |  |   |  |  |   |  |  |   |  |  |   |  |  |   |  |  |   |  |  |   |                  |   |   |  |  |   |  |  |   |  |  |   |  |  |   |  |  |   |  |  |   |  |  |   |
|                                                                                                                                                                                                                                                                                                                                                                                                                                                                                                                                                                                                                                                                                                                                                                                                                                                                                                                                                                                                                                                                                                                                                                                                                                                                                                                                                                                                                                                                                                                                                                                                                                                                                                                                                                                                                                                                                                                                                                                             |                     | 6                |   |  |  |   |  |  |   |  |  |   |  |  |   |  |  |   |  |  |   |  |  |   |  |  |   |                  |    |   |  |  |   |  |  |   |  |  |   |  |  |   |  |  |   |  |  |   |  |  |   |  |  |   |                                                                                                                                                                                                                                                                                                                                                                                                                                                                                                                                                                                                                                                                                                                                                                                                                                                                                                                                                                                                                                                                                                                                                                                                                                                                                                                                                                                                                                                                                                                                                                                                                     |                  |   |   |  |  |   |  |  |   |  |  |   |  |  |   |  |  |   |  |  |   |                  |   |   |  |  |   |  |  |   |  |  |   |  |  |   |  |  |   |  |  |   |                                                                                                                                                                                                                                                                                                                                                                                                                                                                                                                                                                                                                                                                                                                                                                                                                                                                                                                                                                                                                                                                                                                                                                                                                                                                                                                                                                                                                                                                                                                                                                                                                                                                                                                                                                                                |                  |   |   |  |  |   |  |  |   |  |  |   |  |  |   |  |  |   |  |  |   |  |  |   |                  |   |   |  |  |   |  |  |   |  |  |   |  |  |   |  |  |   |  |  |   |  |  |   |
|                                                                                                                                                                                                                                                                                                                                                                                                                                                                                                                                                                                                                                                                                                                                                                                                                                                                                                                                                                                                                                                                                                                                                                                                                                                                                                                                                                                                                                                                                                                                                                                                                                                                                                                                                                                                                                                                                                                                                                                             |                     | 7                |   |  |  |   |  |  |   |  |  |   |  |  |   |  |  |   |  |  |   |  |  |   |  |  |   |                  |    |   |  |  |   |  |  |   |  |  |   |  |  |   |  |  |   |  |  |   |  |  |   |  |  |   |                                                                                                                                                                                                                                                                                                                                                                                                                                                                                                                                                                                                                                                                                                                                                                                                                                                                                                                                                                                                                                                                                                                                                                                                                                                                                                                                                                                                                                                                                                                                                                                                                     |                  |   |   |  |  |   |  |  |   |  |  |   |  |  |   |  |  |   |  |  |   |                  |   |   |  |  |   |  |  |   |  |  |   |  |  |   |  |  |   |  |  |   |                                                                                                                                                                                                                                                                                                                                                                                                                                                                                                                                                                                                                                                                                                                                                                                                                                                                                                                                                                                                                                                                                                                                                                                                                                                                                                                                                                                                                                                                                                                                                                                                                                                                                                                                                                                                |                  |   |   |  |  |   |  |  |   |  |  |   |  |  |   |  |  |   |  |  |   |  |  |   |                  |   |   |  |  |   |  |  |   |  |  |   |  |  |   |  |  |   |  |  |   |  |  |   |
|                                                                                                                                                                                                                                                                                                                                                                                                                                                                                                                                                                                                                                                                                                                                                                                                                                                                                                                                                                                                                                                                                                                                                                                                                                                                                                                                                                                                                                                                                                                                                                                                                                                                                                                                                                                                                                                                                                                                                                                             |                     | 8                |   |  |  |   |  |  |   |  |  |   |  |  |   |  |  |   |  |  |   |  |  |   |  |  |   |                  |    |   |  |  |   |  |  |   |  |  |   |  |  |   |  |  |   |  |  |   |  |  |   |  |  |   |                                                                                                                                                                                                                                                                                                                                                                                                                                                                                                                                                                                                                                                                                                                                                                                                                                                                                                                                                                                                                                                                                                                                                                                                                                                                                                                                                                                                                                                                                                                                                                                                                     |                  |   |   |  |  |   |  |  |   |  |  |   |  |  |   |  |  |   |  |  |   |                  |   |   |  |  |   |  |  |   |  |  |   |  |  |   |  |  |   |  |  |   |                                                                                                                                                                                                                                                                                                                                                                                                                                                                                                                                                                                                                                                                                                                                                                                                                                                                                                                                                                                                                                                                                                                                                                                                                                                                                                                                                                                                                                                                                                                                                                                                                                                                                                                                                                                                |                  |   |   |  |  |   |  |  |   |  |  |   |  |  |   |  |  |   |  |  |   |  |  |   |                  |   |   |  |  |   |  |  |   |  |  |   |  |  |   |  |  |   |  |  |   |  |  |   |
|                                                                                                                                                                                                                                                                                                                                                                                                                                                                                                                                                                                                                                                                                                                                                                                                                                                                                                                                                                                                                                                                                                                                                                                                                                                                                                                                                                                                                                                                                                                                                                                                                                                                                                                                                                                                                                                                                                                                                                                             |                     | 0                |   |  |  |   |  |  |   |  |  |   |  |  |   |  |  |   |  |  |   |  |  |   |  |  |   |                  |    |   |  |  |   |  |  |   |  |  |   |  |  |   |  |  |   |  |  |   |  |  |   |  |  |   |                                                                                                                                                                                                                                                                                                                                                                                                                                                                                                                                                                                                                                                                                                                                                                                                                                                                                                                                                                                                                                                                                                                                                                                                                                                                                                                                                                                                                                                                                                                                                                                                                     |                  |   |   |  |  |   |  |  |   |  |  |   |  |  |   |  |  |   |  |  |   |                  |   |   |  |  |   |  |  |   |  |  |   |  |  |   |  |  |   |  |  |   |                                                                                                                                                                                                                                                                                                                                                                                                                                                                                                                                                                                                                                                                                                                                                                                                                                                                                                                                                                                                                                                                                                                                                                                                                                                                                                                                                                                                                                                                                                                                                                                                                                                                                                                                                                                                |                  |   |   |  |  |   |  |  |   |  |  |   |  |  |   |  |  |   |  |  |   |  |  |   |                  |   |   |  |  |   |  |  |   |  |  |   |  |  |   |  |  |   |  |  |   |  |  |   |
| <code>ToS</code>                                                                                                                                                                                                                                                                                                                                                                                                                                                                                                                                                                                                                                                                                                                                                                                                                                                                                                                                                                                                                                                                                                                                                                                                                                                                                                                                                                                                                                                                                                                                                                                                                                                                                                                                                                                                                                                                                                                                                                            | 1                   | 1                |   |  |  |   |  |  |   |  |  |   |  |  |   |  |  |   |  |  |   |  |  |   |  |  |   |                  |    |   |  |  |   |  |  |   |  |  |   |  |  |   |  |  |   |  |  |   |  |  |   |  |  |   |                                                                                                                                                                                                                                                                                                                                                                                                                                                                                                                                                                                                                                                                                                                                                                                                                                                                                                                                                                                                                                                                                                                                                                                                                                                                                                                                                                                                                                                                                                                                                                                                                     |                  |   |   |  |  |   |  |  |   |  |  |   |  |  |   |  |  |   |  |  |   |                  |   |   |  |  |   |  |  |   |  |  |   |  |  |   |  |  |   |  |  |   |                                                                                                                                                                                                                                                                                                                                                                                                                                                                                                                                                                                                                                                                                                                                                                                                                                                                                                                                                                                                                                                                                                                                                                                                                                                                                                                                                                                                                                                                                                                                                                                                                                                                                                                                                                                                |                  |   |   |  |  |   |  |  |   |  |  |   |  |  |   |  |  |   |  |  |   |  |  |   |                  |   |   |  |  |   |  |  |   |  |  |   |  |  |   |  |  |   |  |  |   |  |  |   |
|                                                                                                                                                                                                                                                                                                                                                                                                                                                                                                                                                                                                                                                                                                                                                                                                                                                                                                                                                                                                                                                                                                                                                                                                                                                                                                                                                                                                                                                                                                                                                                                                                                                                                                                                                                                                                                                                                                                                                                                             |                     | 2                |   |  |  |   |  |  |   |  |  |   |  |  |   |  |  |   |  |  |   |  |  |   |  |  |   |                  |    |   |  |  |   |  |  |   |  |  |   |  |  |   |  |  |   |  |  |   |  |  |   |  |  |   |                                                                                                                                                                                                                                                                                                                                                                                                                                                                                                                                                                                                                                                                                                                                                                                                                                                                                                                                                                                                                                                                                                                                                                                                                                                                                                                                                                                                                                                                                                                                                                                                                     |                  |   |   |  |  |   |  |  |   |  |  |   |  |  |   |  |  |   |  |  |   |                  |   |   |  |  |   |  |  |   |  |  |   |  |  |   |  |  |   |  |  |   |                                                                                                                                                                                                                                                                                                                                                                                                                                                                                                                                                                                                                                                                                                                                                                                                                                                                                                                                                                                                                                                                                                                                                                                                                                                                                                                                                                                                                                                                                                                                                                                                                                                                                                                                                                                                |                  |   |   |  |  |   |  |  |   |  |  |   |  |  |   |  |  |   |  |  |   |  |  |   |                  |   |   |  |  |   |  |  |   |  |  |   |  |  |   |  |  |   |  |  |   |  |  |   |
|                                                                                                                                                                                                                                                                                                                                                                                                                                                                                                                                                                                                                                                                                                                                                                                                                                                                                                                                                                                                                                                                                                                                                                                                                                                                                                                                                                                                                                                                                                                                                                                                                                                                                                                                                                                                                                                                                                                                                                                             |                     | 3                |   |  |  |   |  |  |   |  |  |   |  |  |   |  |  |   |  |  |   |  |  |   |  |  |   |                  |    |   |  |  |   |  |  |   |  |  |   |  |  |   |  |  |   |  |  |   |  |  |   |  |  |   |                                                                                                                                                                                                                                                                                                                                                                                                                                                                                                                                                                                                                                                                                                                                                                                                                                                                                                                                                                                                                                                                                                                                                                                                                                                                                                                                                                                                                                                                                                                                                                                                                     |                  |   |   |  |  |   |  |  |   |  |  |   |  |  |   |  |  |   |  |  |   |                  |   |   |  |  |   |  |  |   |  |  |   |  |  |   |  |  |   |  |  |   |                                                                                                                                                                                                                                                                                                                                                                                                                                                                                                                                                                                                                                                                                                                                                                                                                                                                                                                                                                                                                                                                                                                                                                                                                                                                                                                                                                                                                                                                                                                                                                                                                                                                                                                                                                                                |                  |   |   |  |  |   |  |  |   |  |  |   |  |  |   |  |  |   |  |  |   |  |  |   |                  |   |   |  |  |   |  |  |   |  |  |   |  |  |   |  |  |   |  |  |   |  |  |   |
|                                                                                                                                                                                                                                                                                                                                                                                                                                                                                                                                                                                                                                                                                                                                                                                                                                                                                                                                                                                                                                                                                                                                                                                                                                                                                                                                                                                                                                                                                                                                                                                                                                                                                                                                                                                                                                                                                                                                                                                             |                     | 4                |   |  |  |   |  |  |   |  |  |   |  |  |   |  |  |   |  |  |   |  |  |   |  |  |   |                  |    |   |  |  |   |  |  |   |  |  |   |  |  |   |  |  |   |  |  |   |  |  |   |  |  |   |                                                                                                                                                                                                                                                                                                                                                                                                                                                                                                                                                                                                                                                                                                                                                                                                                                                                                                                                                                                                                                                                                                                                                                                                                                                                                                                                                                                                                                                                                                                                                                                                                     |                  |   |   |  |  |   |  |  |   |  |  |   |  |  |   |  |  |   |  |  |   |                  |   |   |  |  |   |  |  |   |  |  |   |  |  |   |  |  |   |  |  |   |                                                                                                                                                                                                                                                                                                                                                                                                                                                                                                                                                                                                                                                                                                                                                                                                                                                                                                                                                                                                                                                                                                                                                                                                                                                                                                                                                                                                                                                                                                                                                                                                                                                                                                                                                                                                |                  |   |   |  |  |   |  |  |   |  |  |   |  |  |   |  |  |   |  |  |   |  |  |   |                  |   |   |  |  |   |  |  |   |  |  |   |  |  |   |  |  |   |  |  |   |  |  |   |
|                                                                                                                                                                                                                                                                                                                                                                                                                                                                                                                                                                                                                                                                                                                                                                                                                                                                                                                                                                                                                                                                                                                                                                                                                                                                                                                                                                                                                                                                                                                                                                                                                                                                                                                                                                                                                                                                                                                                                                                             |                     | 5                |   |  |  |   |  |  |   |  |  |   |  |  |   |  |  |   |  |  |   |  |  |   |  |  |   |                  |    |   |  |  |   |  |  |   |  |  |   |  |  |   |  |  |   |  |  |   |  |  |   |  |  |   |                                                                                                                                                                                                                                                                                                                                                                                                                                                                                                                                                                                                                                                                                                                                                                                                                                                                                                                                                                                                                                                                                                                                                                                                                                                                                                                                                                                                                                                                                                                                                                                                                     |                  |   |   |  |  |   |  |  |   |  |  |   |  |  |   |  |  |   |  |  |   |                  |   |   |  |  |   |  |  |   |  |  |   |  |  |   |  |  |   |  |  |   |                                                                                                                                                                                                                                                                                                                                                                                                                                                                                                                                                                                                                                                                                                                                                                                                                                                                                                                                                                                                                                                                                                                                                                                                                                                                                                                                                                                                                                                                                                                                                                                                                                                                                                                                                                                                |                  |   |   |  |  |   |  |  |   |  |  |   |  |  |   |  |  |   |  |  |   |  |  |   |                  |   |   |  |  |   |  |  |   |  |  |   |  |  |   |  |  |   |  |  |   |  |  |   |
|                                                                                                                                                                                                                                                                                                                                                                                                                                                                                                                                                                                                                                                                                                                                                                                                                                                                                                                                                                                                                                                                                                                                                                                                                                                                                                                                                                                                                                                                                                                                                                                                                                                                                                                                                                                                                                                                                                                                                                                             |                     | 6                |   |  |  |   |  |  |   |  |  |   |  |  |   |  |  |   |  |  |   |  |  |   |  |  |   |                  |    |   |  |  |   |  |  |   |  |  |   |  |  |   |  |  |   |  |  |   |  |  |   |  |  |   |                                                                                                                                                                                                                                                                                                                                                                                                                                                                                                                                                                                                                                                                                                                                                                                                                                                                                                                                                                                                                                                                                                                                                                                                                                                                                                                                                                                                                                                                                                                                                                                                                     |                  |   |   |  |  |   |  |  |   |  |  |   |  |  |   |  |  |   |  |  |   |                  |   |   |  |  |   |  |  |   |  |  |   |  |  |   |  |  |   |  |  |   |                                                                                                                                                                                                                                                                                                                                                                                                                                                                                                                                                                                                                                                                                                                                                                                                                                                                                                                                                                                                                                                                                                                                                                                                                                                                                                                                                                                                                                                                                                                                                                                                                                                                                                                                                                                                |                  |   |   |  |  |   |  |  |   |  |  |   |  |  |   |  |  |   |  |  |   |  |  |   |                  |   |   |  |  |   |  |  |   |  |  |   |  |  |   |  |  |   |  |  |   |  |  |   |
|                                                                                                                                                                                                                                                                                                                                                                                                                                                                                                                                                                                                                                                                                                                                                                                                                                                                                                                                                                                                                                                                                                                                                                                                                                                                                                                                                                                                                                                                                                                                                                                                                                                                                                                                                                                                                                                                                                                                                                                             |                     | 7                |   |  |  |   |  |  |   |  |  |   |  |  |   |  |  |   |  |  |   |  |  |   |  |  |   |                  |    |   |  |  |   |  |  |   |  |  |   |  |  |   |  |  |   |  |  |   |  |  |   |  |  |   |                                                                                                                                                                                                                                                                                                                                                                                                                                                                                                                                                                                                                                                                                                                                                                                                                                                                                                                                                                                                                                                                                                                                                                                                                                                                                                                                                                                                                                                                                                                                                                                                                     |                  |   |   |  |  |   |  |  |   |  |  |   |  |  |   |  |  |   |  |  |   |                  |   |   |  |  |   |  |  |   |  |  |   |  |  |   |  |  |   |  |  |   |                                                                                                                                                                                                                                                                                                                                                                                                                                                                                                                                                                                                                                                                                                                                                                                                                                                                                                                                                                                                                                                                                                                                                                                                                                                                                                                                                                                                                                                                                                                                                                                                                                                                                                                                                                                                |                  |   |   |  |  |   |  |  |   |  |  |   |  |  |   |  |  |   |  |  |   |  |  |   |                  |   |   |  |  |   |  |  |   |  |  |   |  |  |   |  |  |   |  |  |   |  |  |   |
|                                                                                                                                                                                                                                                                                                                                                                                                                                                                                                                                                                                                                                                                                                                                                                                                                                                                                                                                                                                                                                                                                                                                                                                                                                                                                                                                                                                                                                                                                                                                                                                                                                                                                                                                                                                                                                                                                                                                                                                             |                     | 8                |   |  |  |   |  |  |   |  |  |   |  |  |   |  |  |   |  |  |   |  |  |   |  |  |   |                  |    |   |  |  |   |  |  |   |  |  |   |  |  |   |  |  |   |  |  |   |  |  |   |  |  |   |                                                                                                                                                                                                                                                                                                                                                                                                                                                                                                                                                                                                                                                                                                                                                                                                                                                                                                                                                                                                                                                                                                                                                                                                                                                                                                                                                                                                                                                                                                                                                                                                                     |                  |   |   |  |  |   |  |  |   |  |  |   |  |  |   |  |  |   |  |  |   |                  |   |   |  |  |   |  |  |   |  |  |   |  |  |   |  |  |   |  |  |   |                                                                                                                                                                                                                                                                                                                                                                                                                                                                                                                                                                                                                                                                                                                                                                                                                                                                                                                                                                                                                                                                                                                                                                                                                                                                                                                                                                                                                                                                                                                                                                                                                                                                                                                                                                                                |                  |   |   |  |  |   |  |  |   |  |  |   |  |  |   |  |  |   |  |  |   |  |  |   |                  |   |   |  |  |   |  |  |   |  |  |   |  |  |   |  |  |   |  |  |   |  |  |   |
| <code>ToS</code>                                                                                                                                                                                                                                                                                                                                                                                                                                                                                                                                                                                                                                                                                                                                                                                                                                                                                                                                                                                                                                                                                                                                                                                                                                                                                                                                                                                                                                                                                                                                                                                                                                                                                                                                                                                                                                                                                                                                                                            | 1                   | 1                |   |  |  |   |  |  |   |  |  |   |  |  |   |  |  |   |  |  |   |  |  |   |  |  |   |                  |    |   |  |  |   |  |  |   |  |  |   |  |  |   |  |  |   |  |  |   |  |  |   |  |  |   |                                                                                                                                                                                                                                                                                                                                                                                                                                                                                                                                                                                                                                                                                                                                                                                                                                                                                                                                                                                                                                                                                                                                                                                                                                                                                                                                                                                                                                                                                                                                                                                                                     |                  |   |   |  |  |   |  |  |   |  |  |   |  |  |   |  |  |   |  |  |   |                  |   |   |  |  |   |  |  |   |  |  |   |  |  |   |  |  |   |  |  |   |                                                                                                                                                                                                                                                                                                                                                                                                                                                                                                                                                                                                                                                                                                                                                                                                                                                                                                                                                                                                                                                                                                                                                                                                                                                                                                                                                                                                                                                                                                                                                                                                                                                                                                                                                                                                |                  |   |   |  |  |   |  |  |   |  |  |   |  |  |   |  |  |   |  |  |   |  |  |   |                  |   |   |  |  |   |  |  |   |  |  |   |  |  |   |  |  |   |  |  |   |  |  |   |
|                                                                                                                                                                                                                                                                                                                                                                                                                                                                                                                                                                                                                                                                                                                                                                                                                                                                                                                                                                                                                                                                                                                                                                                                                                                                                                                                                                                                                                                                                                                                                                                                                                                                                                                                                                                                                                                                                                                                                                                             |                     | 2                |   |  |  |   |  |  |   |  |  |   |  |  |   |  |  |   |  |  |   |  |  |   |  |  |   |                  |    |   |  |  |   |  |  |   |  |  |   |  |  |   |  |  |   |  |  |   |  |  |   |  |  |   |                                                                                                                                                                                                                                                                                                                                                                                                                                                                                                                                                                                                                                                                                                                                                                                                                                                                                                                                                                                                                                                                                                                                                                                                                                                                                                                                                                                                                                                                                                                                                                                                                     |                  |   |   |  |  |   |  |  |   |  |  |   |  |  |   |  |  |   |  |  |   |                  |   |   |  |  |   |  |  |   |  |  |   |  |  |   |  |  |   |  |  |   |                                                                                                                                                                                                                                                                                                                                                                                                                                                                                                                                                                                                                                                                                                                                                                                                                                                                                                                                                                                                                                                                                                                                                                                                                                                                                                                                                                                                                                                                                                                                                                                                                                                                                                                                                                                                |                  |   |   |  |  |   |  |  |   |  |  |   |  |  |   |  |  |   |  |  |   |  |  |   |                  |   |   |  |  |   |  |  |   |  |  |   |  |  |   |  |  |   |  |  |   |  |  |   |
|                                                                                                                                                                                                                                                                                                                                                                                                                                                                                                                                                                                                                                                                                                                                                                                                                                                                                                                                                                                                                                                                                                                                                                                                                                                                                                                                                                                                                                                                                                                                                                                                                                                                                                                                                                                                                                                                                                                                                                                             |                     | 3                |   |  |  |   |  |  |   |  |  |   |  |  |   |  |  |   |  |  |   |  |  |   |  |  |   |                  |    |   |  |  |   |  |  |   |  |  |   |  |  |   |  |  |   |  |  |   |  |  |   |  |  |   |                                                                                                                                                                                                                                                                                                                                                                                                                                                                                                                                                                                                                                                                                                                                                                                                                                                                                                                                                                                                                                                                                                                                                                                                                                                                                                                                                                                                                                                                                                                                                                                                                     |                  |   |   |  |  |   |  |  |   |  |  |   |  |  |   |  |  |   |  |  |   |                  |   |   |  |  |   |  |  |   |  |  |   |  |  |   |  |  |   |  |  |   |                                                                                                                                                                                                                                                                                                                                                                                                                                                                                                                                                                                                                                                                                                                                                                                                                                                                                                                                                                                                                                                                                                                                                                                                                                                                                                                                                                                                                                                                                                                                                                                                                                                                                                                                                                                                |                  |   |   |  |  |   |  |  |   |  |  |   |  |  |   |  |  |   |  |  |   |  |  |   |                  |   |   |  |  |   |  |  |   |  |  |   |  |  |   |  |  |   |  |  |   |  |  |   |
|                                                                                                                                                                                                                                                                                                                                                                                                                                                                                                                                                                                                                                                                                                                                                                                                                                                                                                                                                                                                                                                                                                                                                                                                                                                                                                                                                                                                                                                                                                                                                                                                                                                                                                                                                                                                                                                                                                                                                                                             |                     | 4                |   |  |  |   |  |  |   |  |  |   |  |  |   |  |  |   |  |  |   |  |  |   |  |  |   |                  |    |   |  |  |   |  |  |   |  |  |   |  |  |   |  |  |   |  |  |   |  |  |   |  |  |   |                                                                                                                                                                                                                                                                                                                                                                                                                                                                                                                                                                                                                                                                                                                                                                                                                                                                                                                                                                                                                                                                                                                                                                                                                                                                                                                                                                                                                                                                                                                                                                                                                     |                  |   |   |  |  |   |  |  |   |  |  |   |  |  |   |  |  |   |  |  |   |                  |   |   |  |  |   |  |  |   |  |  |   |  |  |   |  |  |   |  |  |   |                                                                                                                                                                                                                                                                                                                                                                                                                                                                                                                                                                                                                                                                                                                                                                                                                                                                                                                                                                                                                                                                                                                                                                                                                                                                                                                                                                                                                                                                                                                                                                                                                                                                                                                                                                                                |                  |   |   |  |  |   |  |  |   |  |  |   |  |  |   |  |  |   |  |  |   |  |  |   |                  |   |   |  |  |   |  |  |   |  |  |   |  |  |   |  |  |   |  |  |   |  |  |   |
|                                                                                                                                                                                                                                                                                                                                                                                                                                                                                                                                                                                                                                                                                                                                                                                                                                                                                                                                                                                                                                                                                                                                                                                                                                                                                                                                                                                                                                                                                                                                                                                                                                                                                                                                                                                                                                                                                                                                                                                             |                     | 5                |   |  |  |   |  |  |   |  |  |   |  |  |   |  |  |   |  |  |   |  |  |   |  |  |   |                  |    |   |  |  |   |  |  |   |  |  |   |  |  |   |  |  |   |  |  |   |  |  |   |  |  |   |                                                                                                                                                                                                                                                                                                                                                                                                                                                                                                                                                                                                                                                                                                                                                                                                                                                                                                                                                                                                                                                                                                                                                                                                                                                                                                                                                                                                                                                                                                                                                                                                                     |                  |   |   |  |  |   |  |  |   |  |  |   |  |  |   |  |  |   |  |  |   |                  |   |   |  |  |   |  |  |   |  |  |   |  |  |   |  |  |   |  |  |   |                                                                                                                                                                                                                                                                                                                                                                                                                                                                                                                                                                                                                                                                                                                                                                                                                                                                                                                                                                                                                                                                                                                                                                                                                                                                                                                                                                                                                                                                                                                                                                                                                                                                                                                                                                                                |                  |   |   |  |  |   |  |  |   |  |  |   |  |  |   |  |  |   |  |  |   |  |  |   |                  |   |   |  |  |   |  |  |   |  |  |   |  |  |   |  |  |   |  |  |   |  |  |   |
|                                                                                                                                                                                                                                                                                                                                                                                                                                                                                                                                                                                                                                                                                                                                                                                                                                                                                                                                                                                                                                                                                                                                                                                                                                                                                                                                                                                                                                                                                                                                                                                                                                                                                                                                                                                                                                                                                                                                                                                             |                     | 6                |   |  |  |   |  |  |   |  |  |   |  |  |   |  |  |   |  |  |   |  |  |   |  |  |   |                  |    |   |  |  |   |  |  |   |  |  |   |  |  |   |  |  |   |  |  |   |  |  |   |  |  |   |                                                                                                                                                                                                                                                                                                                                                                                                                                                                                                                                                                                                                                                                                                                                                                                                                                                                                                                                                                                                                                                                                                                                                                                                                                                                                                                                                                                                                                                                                                                                                                                                                     |                  |   |   |  |  |   |  |  |   |  |  |   |  |  |   |  |  |   |  |  |   |                  |   |   |  |  |   |  |  |   |  |  |   |  |  |   |  |  |   |  |  |   |                                                                                                                                                                                                                                                                                                                                                                                                                                                                                                                                                                                                                                                                                                                                                                                                                                                                                                                                                                                                                                                                                                                                                                                                                                                                                                                                                                                                                                                                                                                                                                                                                                                                                                                                                                                                |                  |   |   |  |  |   |  |  |   |  |  |   |  |  |   |  |  |   |  |  |   |  |  |   |                  |   |   |  |  |   |  |  |   |  |  |   |  |  |   |  |  |   |  |  |   |  |  |   |
|                                                                                                                                                                                                                                                                                                                                                                                                                                                                                                                                                                                                                                                                                                                                                                                                                                                                                                                                                                                                                                                                                                                                                                                                                                                                                                                                                                                                                                                                                                                                                                                                                                                                                                                                                                                                                                                                                                                                                                                             |                     | 7                |   |  |  |   |  |  |   |  |  |   |  |  |   |  |  |   |  |  |   |  |  |   |  |  |   |                  |    |   |  |  |   |  |  |   |  |  |   |  |  |   |  |  |   |  |  |   |  |  |   |  |  |   |                                                                                                                                                                                                                                                                                                                                                                                                                                                                                                                                                                                                                                                                                                                                                                                                                                                                                                                                                                                                                                                                                                                                                                                                                                                                                                                                                                                                                                                                                                                                                                                                                     |                  |   |   |  |  |   |  |  |   |  |  |   |  |  |   |  |  |   |  |  |   |                  |   |   |  |  |   |  |  |   |  |  |   |  |  |   |  |  |   |  |  |   |                                                                                                                                                                                                                                                                                                                                                                                                                                                                                                                                                                                                                                                                                                                                                                                                                                                                                                                                                                                                                                                                                                                                                                                                                                                                                                                                                                                                                                                                                                                                                                                                                                                                                                                                                                                                |                  |   |   |  |  |   |  |  |   |  |  |   |  |  |   |  |  |   |  |  |   |  |  |   |                  |   |   |  |  |   |  |  |   |  |  |   |  |  |   |  |  |   |  |  |   |  |  |   |
|                                                                                                                                                                                                                                                                                                                                                                                                                                                                                                                                                                                                                                                                                                                                                                                                                                                                                                                                                                                                                                                                                                                                                                                                                                                                                                                                                                                                                                                                                                                                                                                                                                                                                                                                                                                                                                                                                                                                                                                             |                     | 8                |   |  |  |   |  |  |   |  |  |   |  |  |   |  |  |   |  |  |   |  |  |   |  |  |   |                  |    |   |  |  |   |  |  |   |  |  |   |  |  |   |  |  |   |  |  |   |  |  |   |  |  |   |                                                                                                                                                                                                                                                                                                                                                                                                                                                                                                                                                                                                                                                                                                                                                                                                                                                                                                                                                                                                                                                                                                                                                                                                                                                                                                                                                                                                                                                                                                                                                                                                                     |                  |   |   |  |  |   |  |  |   |  |  |   |  |  |   |  |  |   |  |  |   |                  |   |   |  |  |   |  |  |   |  |  |   |  |  |   |  |  |   |  |  |   |                                                                                                                                                                                                                                                                                                                                                                                                                                                                                                                                                                                                                                                                                                                                                                                                                                                                                                                                                                                                                                                                                                                                                                                                                                                                                                                                                                                                                                                                                                                                                                                                                                                                                                                                                                                                |                  |   |   |  |  |   |  |  |   |  |  |   |  |  |   |  |  |   |  |  |   |  |  |   |                  |   |   |  |  |   |  |  |   |  |  |   |  |  |   |  |  |   |  |  |   |  |  |   |

För att implementera stacken ska skiftregister `SR4` användas som en del av konstruktionen. Anslut lämpligt antal kretsar för att realisera stacken enligt beskrivningen ovan. Rita nätet samt sätt ut signalerna från Figur 3.1. Specifikation för `SR4` finns sist på tentan.

(10p)

---

## Uppgift 4

Funktionen  $f = f(x_1, x_2, x_3)$  används i en krets med fyra D-element, insignal  $x$  och utsignal  $u$ , som ser ut på följande vis:

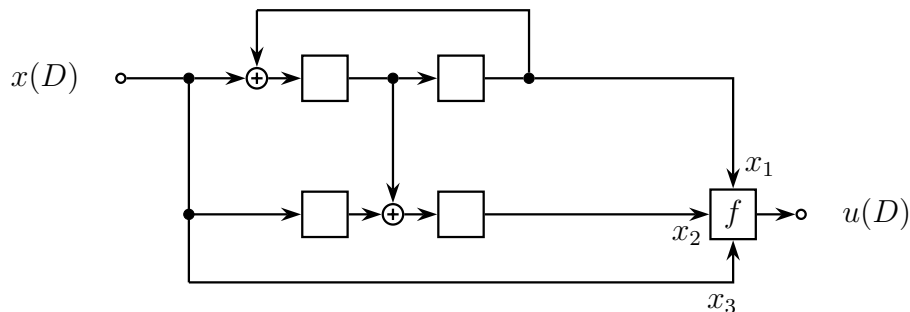

- För vilka av de booleska uttrycken  $f_1 = x_1x_2' \vee x_1'x_2$ ;  $f_2 = x_2 \wedge (x_1 \vee x_3)$ ;  $f_3 = x_2 \vee x_3$ ;  $f_4 = x_1 \wedge (x_2 \vee x_1x_2x_3')$  är  $f = f_i$  en linjär funktion?
- Låt  $f$  vara en linjär funktion från a). Bestäm om kretsen är minimal. Bevisa att den är minimal, eller, om så inte är fallet, ta fram en ekvivalent men minimal krets.
- Bestäm systemfunktionen  $G(D)$  för den minimala kretsen.

(2+4+4=10p)

---

## Uppgift 5

Att kunna räkna på vanligt vis med mängder som innehåller ett ändligt antal element är viktigt i många digitala system. Låt oss betrakta ringen  $\mathbb{Z}_{1021}$ , med addition och multiplikation modulo 1021. Vi noterar också att 1021 är ett primtal. För att representera ett element  $u$  i  $\mathbb{Z}_{1021}$  använder vi en vektor med 10 bitar  $\mathbf{u} = (u_9, u_8, \dots, u_0)$ .

- Konstruera en kombinatorisk krets som kan utföra addition av två element  $x$  och  $y$  från  $\mathbb{Z}_{1021}$  och generera resultatet  $u$  som också är ett element från  $\mathbb{Z}_{1021}$ . Signalen skall vara två 10-bitars vektorer och utsignalen ska vara en 10-bitars vektor. Konstruktionen kan med fördel innehålla minst ett iterativt kombinatoriskt nät, dvs en kaskadkoppling av ett antal mindre block som är sammankopplade. Rita en tydlig bild över nätet och eventuella komponenter!
- Hitta alla lösningar till ekvationen  $5x^2 - 11x - 1 = 1020$  definierad över  $\mathbb{Z}_{1021}$ . (Enbart prövning ger inga poäng)

(7+3=10p)

---

God Fortsättning på 2018!

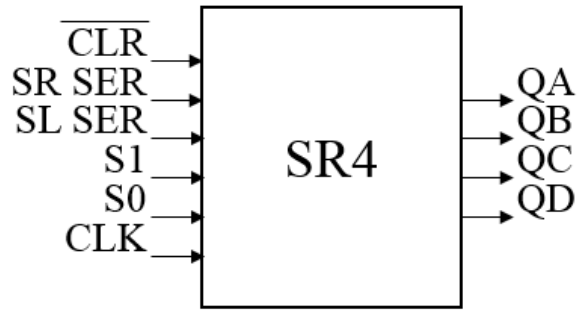

**SR4** 4-bitars skiftregister

| INPUTS |      |    |     |        |        | OUTPUTS |     |     |     |
|--------|------|----|-----|--------|--------|---------|-----|-----|-----|
| CLR    | MODE |    | CLK | SERIAL |        | QA      | QB  | QC  | QD  |
|        | S1   | S0 |     | SL SER | SR SER |         |     |     |     |
| L      | X    | X  | ↑   | X      | X      | L       | L   | L   | L   |
| H      | L    | H  | ↑   | X      | H      | H       | QAn | QBn | QCn |
| H      | L    | H  | ↑   | X      | L      | L       | QAn | QBn | QCn |
| H      | H    | L  | ↑   | H      | X      | QBn     | QCn | QDn | H   |
| H      | H    | L  | ↑   | L      | X      | QBn     | QCn | QDn | L   |
| H      | L    | L  | X   | X      | X      | QA0     | QB0 | QC0 | QD0 |