

SDLS085

SN54251, SN54LS251, SN74251, SN74LS251, (SN54S251, SN54LS251, SN74S251, SN74LS251) DATA SELECTORS/MULTIPLEXERS WITH 3-STATE OUTPUTS

DECEMBER 1972—REVISED MARCH 1988

- Three-State Versions of '151, 'LS151, 'S151
- Three-State Outputs Interface Directly with System Bus
- Perform Parallel-to-Serial Conversion
- Permit Multiplexing from N-lines to One Line
- Complementary Outputs Provide True and Inverted Data
- Fully Compatible with Most TTL Circuits

SN54251, SN54LS251, SN54S251, SN74251 . . . J OR W PACKAGE
 SN74LS251, SN74S251 . . . N PACKAGE
 (TOP VIEW)

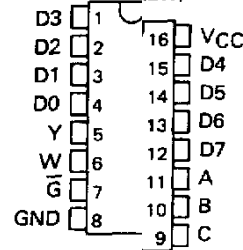

SN54LS251, SN54S251, SN74LS251, SN74S251 . . . FK PACKAGE
 (TOP VIEW)

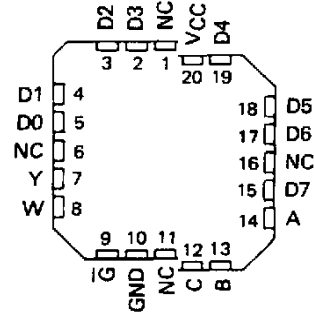

NC - No internal connection

TYPE	MAX NO. OF COMMON OUTPUTS	TYPICAL AVG PROP DELAY TIME (D TO Y)	TYPICAL POWER DISSIPATION
SN54251	49	17 ns	250 mW
SN74251	129	17 ns	250 mW
SN54LS251	49	17 ns	35 mW
SN74LS251	129	17 ns	35 mW
SN54S251	39	8 ns	275 mW
SN74S251	129	8 ns	275 mW

description

These monolithic data selectors/multiplexers contain full on-chip binary decoding to select one-of-eight data sources and feature a strobe-controlled three-state output. The strobe must be at a low logic level to enable these devices. The three-state outputs permit a number of outputs to be connected to a common bus. When the strobe input is high, both outputs are in a high-impedance state in which both the upper and lower transistors of each totem-pole output are off, and the output neither drives nor loads the bus significantly. When the strobe is low, the outputs are activated and operate as standard TTL totem-pole outputs.

To minimize the possibility that two outputs will attempt to take a common bus to opposite logic levels, the output control circuitry is designed so that the average output disable time is shorter than the average output enable time. The SN54251 and SN74251 have output clamp diodes to attenuate reflections on the bus line.

FUNCTION TABLE

INPUTS				OUTPUTS	
SELECT	ENAB			Y	W
C B A	LE G				
X X X	H			Z	2
L L L	L			D0	$\overline{D0}$
L L H	L			D1	$\overline{D1}$
L H L	L			D2	$\overline{D2}$
L H H	L			D3	$\overline{D3}$
H L L	L			D4	$\overline{D4}$
H L H	L			D5	$\overline{D5}$
H H L	L			D6	$\overline{D6}$
H H H	L			D7	$\overline{D7}$

H = high logic level, L = low logic level
 X = irrelevant, Z = high impedance (off)
 D0, D1 . . . D7 = the level of the respective D input

PRODUCTION DATA documents contain information current as of publication date. Products conform to specifications per the terms of Texas Instruments standard warranty. Production processing does not necessarily include testing of all parameters.



POST OFFICE BOX 655012 • DALLAS, TEXAS 75265

**SN54251, SN54LS251, SN54S251,
SN74251, SN74LS251, (TIM9905), SN74S251
DATA SELECTORS/MULTIPLEXERS WITH 3-STATE OUTPUTS**

logic diagram (positive logic)

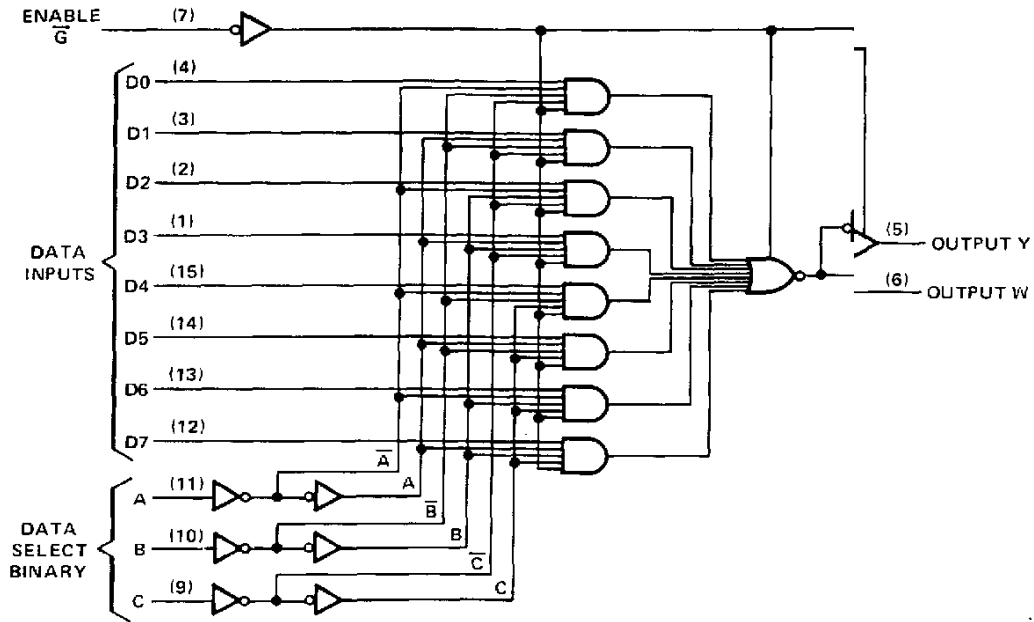

logic symbol†

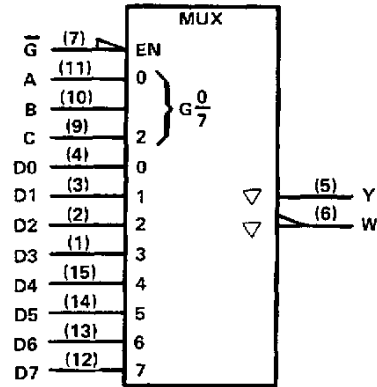

†This symbol is in accordance with ANSI/IEEE Std. 91-1984 and IEC Publication 617-12. Pin numbers shown are for D, J, N, and W packages.

DATA SELECTORS/MULTIPLEXERS WITH SN54251, SN74251 TH 3-STATE OUTPUTS

absolute maximum ratings over operating free-air temperature range (unless otherwise noted)

Supply voltage, V_{CC} (see Note 1)	7 V
Input voltage	5.5 V
Off-state output voltage	5.5 V
Operating free-air temperature range: SN54251	-55°C to 125°C
SN74251	0°C to 70°C
Storage temperature range	-65°C to 150°C

NOTE 1: Voltage values are with respect to network ground terminal.

recommended operating conditions

	SN54251			SN74251			UNIT
	MIN	NOM	MAX	MIN	NOM	MAX	
Supply voltage, V_{CC}	4.5	5	5.5	4.75	5	5.25	V
High-level output current, I_{OH}			-2			-5.2	mA
Low-level output current, I_{OL}			16			16	mA
Operating free-air temperature, T_A	-55		125	0		70	°C

electrical characteristics over recommended operating free-air temperature range (unless otherwise noted)

PARAMETER	TEST CONDITIONS†	MIN	TYP‡	MAX	UNIT	
V_{IH} High-level input voltage		2			V	
V_{IL} Low-level input voltage				0.8	V	
V_{IK} Input clamp voltage	$V_{CC} = \text{MIN}, I_I = -12 \text{ mA}$			-1.5	V	
V_{OH} High-level output voltage	$V_{CC} = \text{MIN}, V_{IH} = 2 \text{ V}, V_{IL} = 0.8 \text{ V}, I_{OH} = \text{MAX}$	2.4	3.2		V	
V_{OL} Low-level output voltage	$V_{CC} = \text{MIN}, V_{IH} = 2 \text{ V}, V_{IL} = 0.8 \text{ V}, I_{OL} = 16 \text{ mA}$		0.2	0.4	V	
I_{OZ} Off-state (high-impedance-state) output current	$V_{CC} = \text{MAX}, V_{IH} = 2 \text{ V}$	$V_O = 2.4 \text{ V}$		40	μA	
		$V_O = 0.4 \text{ V}$		-40		
V_O Output clamp voltage	$V_{CC} = \text{MAX}, V_{IH} = 4.5 \text{ V}$	$I_O = -12 \text{ mA}$		-1.5	V	
		$I_O = 12 \text{ mA}$		$V_{CC} + 1.5$		
I_I Input current at maximum input voltage	$V_{CC} = \text{MAX}, V_I = 5.5 \text{ V}$			1	mA	
I_{IH} High-level input current	$V_{CC} = \text{MAX}, V_I = 2.4 \text{ V}$			40	μA	
I_{IL} Low-level input current	$V_{CC} = \text{MAX}, V_I = 0.4 \text{ V}$			-1.6	mA	
I_{OS} Short-circuit output current§	$V_{CC} = \text{MAX}$			-18	-55	mA
I_{CC} Supply current	$V_{CC} = \text{MAX},$ All inputs at 4.5 V, All outputs open			38	62	mA

†For conditions shown as MIN or MAX, use the appropriate value specified under recommended operating conditions for the applicable type.

‡All typical values are at $V_{CC} = 5 \text{ V}, T_A = 25^\circ\text{C}$.

§Not more than one output should be shorted at a time.



SN54251, SN74251 DATA SELECTORS/MULTIPLEXERS WITH 3-STATE OUTPUTS

switching characteristics, $V_{CC} = 5\text{ V}$, $T_A = 25^\circ\text{ C}$

PARAMETER†	FROM (INPUT)	TO (OUTPUT)	TEST CONDITIONS	MIN	TYP	MAX	UNIT
t_{PLH}	A, B, or C (4 levels)	Y	$C_L = 50\text{ pF}$, $R_L = 400\ \Omega$, See Note 2		29	45	ns
t_{PHL}					28	45	
t_{PLH}	A, B, or C (3 levels)	W			20	33	ns
t_{PHL}					21	33	
t_{PLH}	Any D	Y			17	28	ns
t_{PHL}					18	28	
t_{PLH}	Any D	W			10	15	ns
t_{PHL}					9	15	
t_{PZH}	\bar{G}	Y			17	27	ns
t_{PZL}					26	40	
t_{PZH}	\bar{G}	W			17	27	ns
t_{PZL}					24	40	
t_{PHZ}	\bar{G}	Y	$C_L = 5\text{ pF}$, $R_L = 400\ \Omega$, See Note 2		5	8	ns
t_{PLZ}					15	23	
t_{PHZ}	\bar{G}	W			5	8	ns
t_{PLZ}					15	23	

† t_{PLH} = Propagation delay time, low-to-high-level output
 t_{PHL} = Propagation delay time, high-to-low-level output
 t_{PZH} = Output enable time to high level
 t_{PZL} = Output enable time to low level
 t_{PHZ} = Output disable time from high level
 t_{PLZ} = Output disable time from low level

NOTE 2: Load circuits and voltage waveforms are shown in Section 1.

schematics of inputs and outputs

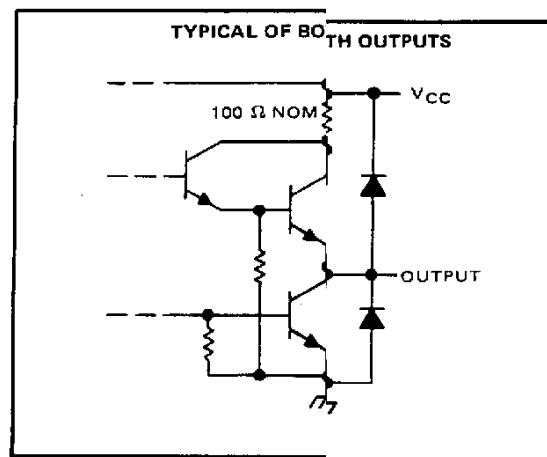
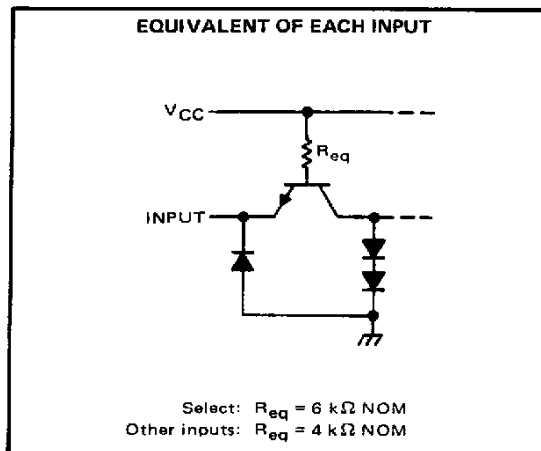

TEXAS
INSTRUMENTS

POST OFFICE BOX 655012 • DALLAS, TEXAS 75265

SN54LS251, SN74LS251 DATA SELECTORS/MULTIPLEXERS WITH 3-STATE OUTPUTS

absolute maximum ratings over operating free-air temperature range (unless otherwise noted)

Supply voltage, V_{CC} (see Note 1)	7 V
Input voltage	7 V
Off-state output voltage	5.5 V
Operating free-air temperature range: SN54LS251	55°C to 125°C
SN74LS251	0°C to 70°C
Storage temperature range	-65°C to 150°C

NOTE 1: Voltage values are with respect to network ground terminal.

recommended operating conditions

	SN54LS251			SN74LS251			UNIT
	MIN	NOM	MAX	MIN	NOM	MAX	
V_{CC} Supply voltage	4.5	5	5.5	4.75	5	5.25	V
V_{IH} High-level input voltage	2			2			V
V_{IL} Low-level input voltage				0.7			V
I_{OH} High-level output current				-1			mA
I_{OL} Low-level output current				-2.6			mA
T_A Operating free-air temperature	-55 to 125			0 to 70			°C

electrical characteristics over recommended operating free-air temperature range (unless otherwise noted)

PARAMETER	TEST CONDITIONS†	SN54LS251		SN74LS251		UNIT	
		MIN	TYP ‡	MAX	MIN		TYP ‡
V_{IK}	$V_{CC} = \text{MIN}, I_I = -18 \text{ mA}$			-1.5		V	
V_{OH}	$V_{CC} = \text{MIN}, V_{IH} = 2 \text{ V}, V_{IL} = \text{MAX}, I_{OH} = \text{MAX}$	2.4	3.4	2.4	3.1	V	
V_{OL}	$V_{CC} = \text{MIN}, V_{IH} = 2 \text{ V}, V_{IL} = \text{MAX}$	$I_{OL} = 4 \text{ mA}$		0.25	0.4	V	
		$I_{OL} = 8 \text{ mA}$		0.35	0.5		
I_{OZ}	$V_{CC} = \text{MAX}, V_{IH} = 2 \text{ V}$	$V_O = 2.7 \text{ V}$		20		µA	
		$V_O = 0.4 \text{ V}$		-20			
I_I	$V_{CC} = \text{MAX}, V_I = 7 \text{ V}$			0.1		mA	
I_{IH}	$V_{CC} = \text{MAX}, V_I = 2.7 \text{ V}$			20		µA	
I_{IL}	Enable \bar{G} All other	$V_{CC} = \text{MAX}, V_I = 0.4$		-0.2		mA	
				-0.4			
$I_{OS}§$	$V_{CC} = \text{MAX}$	-30		-130		mA	
I_{CC}	$V_{CC} = \text{MAX},$ See Note 3	Condition A	6.1	10	6.1	10	mA
		Condition B	7.1	12	7.1	12	

† For conditions shown as MIN or MAX, use the appropriate value specified under recommended operating conditions for the applicable type.

‡ All typical values are at $V_{CC} = 5 \text{ V}, T_A = 25^\circ\text{C}$.

§ Not more than one output should be shorted at a time, and duration of the short-circuit should not exceed one second.

NOTE 3: I_{CC} is measured with the outputs open and all data and select inputs at 4.5 V under the following conditions:

- A. Enable grounded.
- B. Strobe at 4.5 V.



SN54LS251, SN74LS251 (TIM9905)

DATA SELECTORS/MULTIPLEXERS WITH 3-STATE OUTPUTS

switching characteristics, $V_{CC} = 5\text{ V}$, $T_A = 25^\circ\text{C}$

PARAMETER†	FROM (INPUT)	TO (OUTPUT)	TEST CONDITIONS	MIN	TYP	MAX	UNIT
t_{PLH}	A, B, or C (4 levels)	Y	$C_L = 15\text{ pF}$, $R_L = 2\text{ k}\Omega$, See Note 2		29	45	ns
t_{PHL}					28	45	
t_{PLH}	A, B, or C (3 levels)	W			20	33	ns
t_{PHL}					21	33	
t_{PLH}	Any D	Y			17	28	ns
t_{PHL}					18	28	
t_{PLH}	Any D	W			10	15	ns
t_{PHL}					9	15	
t_{PZH}	\bar{G}	Y			30	45	ns
t_{PZL}					26	40	
t_{PZH}	\bar{G}	W		17	27	ns	
t_{PZL}				24	40		
t_{PHZ}	\bar{G}	Y	$C_L = 5\text{ pF}$, $R_L = 2\text{ k}\Omega$, See Note 2		30	45	ns
t_{PLZ}					15	25	
t_{PHZ}	\bar{G}	W			37	55	ns
t_{PLZ}					15	25	

† t_{PLH} = Propagation delay time, low-to-high-level output
 t_{PHL} = Propagation delay time, high-to-low-level output
 t_{PZH} = Output enable time to high level
 t_{PZL} = Output enable time to low level
 t_{PHZ} = Output disable time from high level
 t_{PLZ} = Output disable time from low level

NOTE 2: Load circuits and voltage waveforms are shown in Section 1.

schematics of inputs and outputs

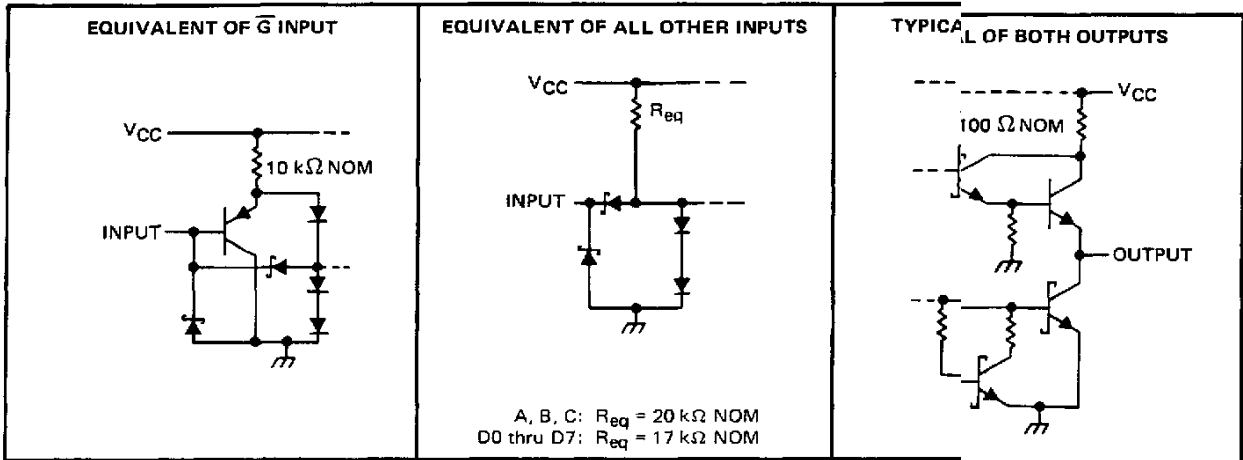

TEXAS
INSTRUMENTS

POST OFFICE BOX 655012 • DALLAS, TEXAS 75265

DATA SELECTORS/MULTIPLEXERS WITH 3-STATE OUTPUTS

SN54S251, SN74S251

absolute maximum ratings over operating free-air temperature range (unless otherwise noted)

Supply voltage, V_{CC} (see Note 1)		7 V
Input voltage		5.5 V
Off-state output voltage		5.5 V
Operating free-air temperature range: SN54S251		-55°C to 125°C
SN74S251		0°C to 70°C
Storage temperature range		-65°C to 150°C

NOTE 1: Voltage values are with respect to network ground terminal.

recommended operating conditions

	SN54S251			SN74S251			UNIT
	MIN	NOM	MAX	MIN	NOM	MAX	
Supply voltage, V_{CC}	4.5	5	5.5	4.75	5	5.25	V
High-level output current, I_{OH}			-5			-6.5	mA
Low-level output current, I_{OL}			2			20	mA
Operating free-air temperature, T_A	-55		125	0		70	°C

electrical characteristics over recommended operating free-air temperature range (unless otherwise noted)

PARAMETER	TEST CONDITIONS†	MIN	TYP‡	MAX	UNIT
V_{IH} High-level input voltage		2			V
V_{IL} Low-level input voltage				0.8	V
V_{IK} Input clamp voltage	$V_{CC} = \text{MIN}, I_I = -18 \text{ mA}$			-1.2	V
V_{OH} High-level output voltage	$V_{CC} = \text{MIN}, V_{IH} = 2 \text{ V}, V_{IL} = 0.8 \text{ V}, I_{OH} = \text{MAX}$	SN54S	2.4	3.4	V
		SN74S	2.4	3.2	
V_{OL} Low-level output voltage	$V_{CC} = \text{MIN}, V_{IH} = 2 \text{ V}, V_{IL} = 0.8 \text{ V}, I_{OL} = 20 \text{ mA}$			0.5	V
I_{OZ} Off-state (high-impedance-state) output current	$V_{CC} = \text{MAX}, V_{IH} = 2 \text{ V}$	$V_O = 2.4 \text{ V}$		50	μA
		$V_O = 0.5 \text{ V}$		-50	
I_I Input current at maximum input voltage	$V_{CC} = \text{MAX}, V_I = 5.5 \text{ V}$			1	mA
I_{IH} High-level input current	$V_{CC} = \text{MAX}, V_I = 2.7 \text{ V}$			50	μA
I_{IL} Low-level input current	$V_{CC} = \text{MAX}, V_I = 0.5 \text{ V}$			-2	mA
I_{OS} Short-circuit output current §	$V_{CC} = \text{MAX}$	-40		-100	mA
I_{CC} Supply current	$V_{CC} = \text{MAX},$ All inputs at 4.5 V, All outputs open		55	85	mA

† For conditions shown as MIN or MAX, use the appropriate value specified under recommended operating conditions for the applicable type.

‡ All typical values are at $V_{CC} = 5 \text{ V}, T_A = 25^\circ \text{C}$.

§ Not more than one output should be shorted at a time, and duration of the short-circuit should not exceed one second.



SN54S251, SN74S251

DATA SELECTORS/MULTIPLEXERS WITH 3-STATE OUTPUTS

switching characteristics, $V_{CC} = 5\text{ V}$, $T_A = 25^\circ\text{C}$

PARAMETER†	FROM (INPUT)	TO (OUTPUT)	TEST CONDITIONS	MIN	TYP	MAX	UNIT	
t_{PLH}	A, B, or C (4 levels)	Y	$C_L = 15\text{ pF}$, $R_L = 280\ \Omega$, See Note 2		12	18	ns	
t_{PHL}					13	19.5		
t_{PLH}	A, B, or C (3 levels)	W			10	15	ns	
t_{PHL}					9	13.5		
t_{PLH}	Any D	Y			8	12	ns	
t_{PHL}					8	12		
t_{PLH}	Any D	W			4.5	7	ns	
t_{PHL}					4.5	7		
t_{PZH}	\bar{G}	Y	$C_L = 50\text{ pF}$, $R_L = 280\ \Omega$, See Note 2		13	19.5	ns	
t_{PZL}					14	21		
t_{PZH}	\bar{G}	W			13	19.5	ns	
t_{PZL}					14	21		
t_{PHZ}	\bar{G}	Y		$C_L = 5\text{ pF}$, $R_L = 280\ \Omega$, See Note 2		5.5	8.5	ns
t_{PLZ}						9	14	
t_{PHZ}	\bar{G}	W			5.5	8.5	ns	
t_{PLZ}					9	14		

† t_{PLH} = Propagation delay time, low-to-high-level output

t_{PHL} = Propagation delay time, high-to-low-level output

t_{PZH} = Output enable time to high level

t_{PZL} = Output enable time to low level

t_{PHZ} = Output disable time from high level

t_{PLZ} = Output disable time from low level

NOTE 2: Load circuits and voltage waveforms are shown in Section 1.

schematics of inputs and outputs

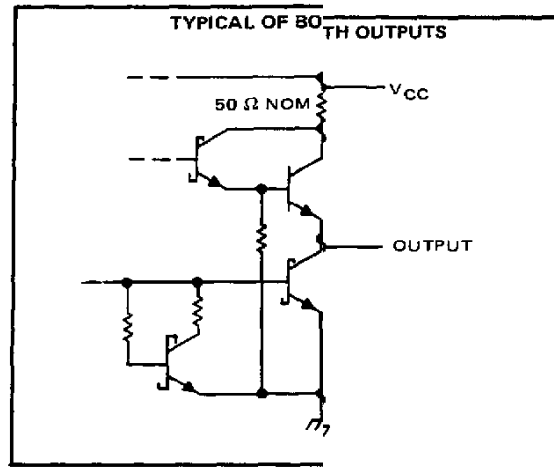
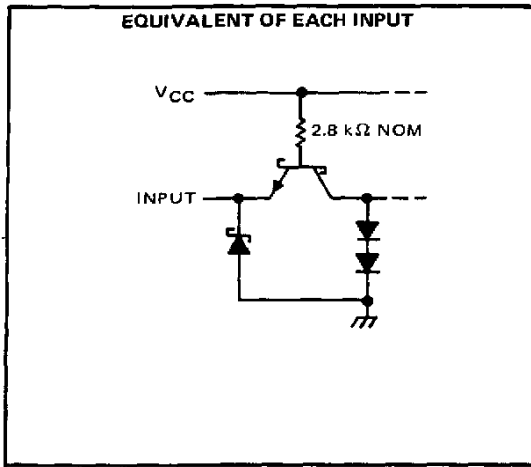

TEXAS INSTRUMENTS

POST OFFICE BOX 655012 • DALLAS, TEXAS 75265

IMPORTANT NOTICE

Texas Instruments and its subsidiaries (TI) reserve the right to make changes to their products or to discontinue any product or service without notice, and advise customers to obtain the latest version of relevant information to verify, before placing orders, that information being relied on is current and complete. All products are sold subject to the terms and conditions of sale supplied at the time of order acknowledgement, including those pertaining to warranty, patent infringement, and limitation of liability.

TI warrants performance of its semiconductor products to the specifications applicable at the time of sale in accordance with TI's standard warranty. Testing and other quality control techniques are utilized to the extent TI deems necessary to support this warranty. Specific testing of all parameters of each device is not necessarily performed, except those mandated by government requirements.

CERTAIN APPLICATIONS USING SEMICONDUCTOR PRODUCTS MAY INVOLVE POTENTIAL RISKS OF DEATH, PERSONAL INJURY, OR SEVERE PROPERTY OR ENVIRONMENTAL DAMAGE ("CRITICAL APPLICATIONS"). TI SEMICONDUCTOR PRODUCTS ARE NOT DESIGNED, AUTHORIZED, OR WARRANTED TO BE SUITABLE FOR USE IN LIFE-SUPPORT DEVICES OR SYSTEMS OR OTHER CRITICAL APPLICATIONS. INCLUSION OF TI PRODUCTS IN SUCH APPLICATIONS IS UNDERSTOOD TO BE FULLY AT THE CUSTOMER'S RISK.

In order to minimize risks associated with the customer's applications, adequate design and operating safeguards must be provided by the customer to minimize inherent or procedural hazards.

TI assumes no liability for applications assistance or customer product design. TI does not warrant or represent that any license, either express or implied, is granted under any patent right, copyright, mask work right, or other intellectual property right of TI covering or relating to any combination, machine, or process in which such semiconductor products or services might be or are used. TI's publication of information regarding any third party's products or services does not constitute TI's approval, warranty or endorsement thereof.