

2N6058 JANTX, JTXV

2N6059 JANTX, JTXV



Processed per MIL-PRF-19500/502

PNP DARLINGTON POWER SILICON TRANSISTOR

MAXIMUM RATINGS

Ratings	Symbol	2N6058	2N6059	Units
Collector-Emitter Voltage	V_{CEO}	80	100	Vdc
Collector-Base Voltage	V_{CBO}	80	100	Vdc
Emitter-Base Voltage	V_{EBO}	5.0		Vdc
Base Current	I_B	0.2		Adc
Collector Current	I_C	12		Adc
Total Power Dissipation ⁽¹⁾ @ $T_C = 25^{\circ}C$ @ $T_C = 100^{\circ}C$	P_T	150 75		W W
Operating & Storage Junction Temperature Range	T_J, T_{stg}	-55 to +175		$^{\circ}C$

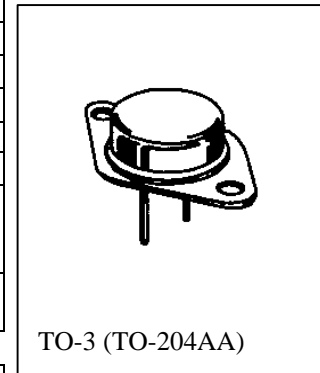

THERMAL CHARACTERISTICS

Characteristics	Symbol	Max.	Unit
Thermal Resistance, Junction-to-Case	$R_{\theta JC}$	1.0	$^{\circ}C/W$

 1) Derate linearly 1.0 W/ $^{\circ}C$ for $T_C > 25^{\circ}C$

ELECTRICAL CHARACTERISTICS ($T_C = 25^{\circ}C$ unless otherwise noted)

Characteristics	Symbol	Min.	Max.	Unit
-----------------	--------	------	------	------

OFF CHARACTERISTICS

Collector-Emitter Breakdown Voltage $I_C = 100$ mAdc	2N6058 2N6059	$V_{(BR)CEO}$	80 100	Vdc
Collector-Emitter Cutoff Current $V_{CE} = 40$ Vdc $V_{CE} = 50$ Vdc	2N6058 2N6059	I_{CEO}	1.0 1.0	mAdc
Collector-Emitter Cutoff Current $V_{CE} = 80$ Vdc, $V_{BE} = 1.5$ Vdc $V_{CE} = 100$ Vdc, $V_{BE} = 1.5$ Vdc	2N6058 2N6059	I_{CEX}	0.5 0.5	mAdc
Emitter-Base Cutoff Current $V_{EB} = 5.0$ Vdc		I_{EBO}	2.0	mAdc

2N6058, 2N6059 JAN SERIES

ELECTRICAL CHARACTERISTICS (con't)

Characteristics	Symbol	Min.	Max.	Unit
-----------------	--------	------	------	------

ON CHARACTERISTICS ⁽²⁾

Forward-Current Transfer Ratio I _C = 1.0 Adc, V _{CE} = 3.0 Vdc I _C = 6.0 Adc, V _{CE} = 3.0 Vdc I _C = 12 Adc, V _{CE} = 3.0 Vdc	h _{FE}	1,000 1,000 150	18,000	
Collector-Emitter Saturation Voltage I _C = 12 Adc, I _B = 120 mAcd I _C = 6.0 Adc, I _B = 24 mAcd	V _{CE(sat)}		3.0 2.0	Vdc
Base-Emitter Saturation Voltage I _C = 12 Adc, I _B = 120 mAcd	V _{BE(sat)}		4.0	Vdc
Base-Emitter Voltage I _C = 6.0 Adc, V _{CE} = 3.0 Vdc	V _{BE(on)}		2.8	Vdc

DYNAMIC CHARACTERISTICS

Magnitude of Common Emitter Small-Signal Short-Circuit Forward Current Transfer Ratio I _C = 5.0Adc, V _{CE} = 3.0 Vdc, f = 1.0 MHz	h _{fe}	10	250	
Small-Signal Short-Circuit Forward Current Transfer Ratio I _C = 5.0 Adc, V _{CE} = 3.0 Vdc, f = 1.0 kHz	h _{fe}	1,000		
Output Capacitance V _{CB} = 10 Vdc, I _E = 0, 100 kHz ≤ f ≤ 1.0 MHz	C _{obo}		300	pF

SWITCHING CHARACTERISTICS

Turn-On Time V _{CC} = 30 Vdc; I _C = 5.0 Adc; I _B = 20 mAcd	t _{on}		2.0	μs
Turn-Off Time V _{CC} = 30 Vdc; I _C = 5.0 Adc; I _{B1} = I _{B2} = 20 mAcd	t _{off}		10	μs

SAFE OPERATING AREA

DC Tests				
T _C = +25 ⁰ C + 10 ⁰ C, -0 ⁰ , 1 Cycle, t ≥ 1.0 s				
Test 1				
V _{CE} = 12.5 Vdc, I _C = 12 Adc				
Test 2				
V _{CE} = 30 Vdc, I _C = 5.0 Adc				
Test 3				
V _{CE} = 70 Vdc, I _C = 200 mAcd		2N6058		
Test 4				
V _{CE} = 90 Vdc, I _C = 155 mAcd		2N6059		

(2) Pulse Test: Pulse Width = 300μs, Duty Cycle ≤ 2.0%.