

Digital Communications – Advanced Course (ETTN01)

The Project

1. Each project group consists of two students.
2. Each project group should, as soon as possible, send an email to goran.lindell@eit.lth.se containing:
Name and email address to each project member.
3. The project group should contact Göran Lindell **to decide about project and articles!**
4. Each project group should **write a project report.**
5. The **structure of the project report** should follow journal articles published by IEEE. However, two columns are not needed.
6. The project report should be written in English **with your own words, tables and figures**, and contain **6-9 pages**.
Observe copyright rules: “copy & paste” is in general strictly forbidden!
7. **NOTE!** The project report should be **clearly and well written**, and written **to the other students in this course!**

8. The project report should be sent in .pdf format to goran.lindell@eit.lth.se before **Thursday 3 December, 17.00.**
9. Each project group should also in English present the project work in an **oral presentation (12 – 15 min, no more and no less).**
NOTE! The project presentation should be clear and aimed **to the other students in this course!**
After the oral presentation the project report and the presentation will be discussed (5 min).
10. Each group should have **relevant comments and questions** on the project report and on the oral presentation **of another group.**
11. A project report will be sent to each project group from goran.lindell@eit.lth.se on **Sunday 6 December** (at the latest).

Also observe:

Articles and conference papers from the IEEE database "IEEE Xplore"

<http://ieeexplore.ieee.org/Xplore/DynWel.jsp>

is strongly recommended to get reliable technical information.

A list of project examples is available in the slides from the first lecture of this course, found on the home page. You are free to choose other topics than those examples.

In the project, a communication application/technical problem/problem area, relevant for the course, should be investigated. The written report, and the oral presentation, should contain the results of this investigation.

The choice of project is mainly done by the project group but it has to be approved by Göran Lindell.

Some examples of applications/systems studied in previous projects:

- Mobile telephony/broadband (GSM, EDGE, 3G, 4G,...)
- Internet
- Modem (e.g., ADSL)
- WLAN (Wireless Local Area Network)
- Digital TV
- MIMO, future systems (4G, 5G,...)
- OFDM/MIMO
- GPS (Global Positioning System)
- Bluetooth
- Home electronics (CD, DVD, remote controls, etc.)

$M = 2$	P_b	$Q\left(\sqrt{d_{\min}^2 \frac{\varepsilon_b}{N_0}}\right)$, (4.55)
	d_{\min}^2	$0 \leq d_{\min}^2 \leq 2$, (4.57)
	ρ	ρ_{bin} , (2.21)
M-ary PAM	P_s	$2\left(1 - \frac{1}{M}\right) Q\left(\sqrt{d_{\min}^2 \frac{\varepsilon_b}{N_0}}\right)$, (5.35)
	d_{\min}^2	$\frac{6 \log_2(M)}{M^2 - 1}$, Table 4.1 on page 281, (2.50)
	ρ	$\rho_{2-PAM} \cdot \log_2(M)$, (2.220)
M-ary PSK	P_s	$< 2Q\left(\sqrt{d_{\min}^2 \frac{\varepsilon_b}{N_0}}\right)$, (5.43)
	d_{\min}^2	$2 \sin^2(\pi/M) \log_2(M)$, Table 4.1, Fig. 5.11
	ρ	$\rho_{BPSK} \cdot \log_2(M)$, (2.229)
M-ary QAM (rect., k even) (QPSK with $M = 4$)	P_s	$4\left(1 - \frac{1}{\sqrt{M}}\right) Q\left(\sqrt{d_{\min}^2 \frac{\varepsilon_b}{N_0}}\right) -$ $4\left(1 - \frac{1}{\sqrt{M}}\right)^2 Q^2\left(\sqrt{d_{\min}^2 \frac{\varepsilon_b}{N_0}}\right)$, (5.50)
	d_{\min}^2	$\frac{3 \log_2(M)}{M-1}$, Table 4.1, Subsection 2.4.5.1
	ρ	$\rho_{BPSK} \cdot \log_2(M)$, (2.229)
M-ary FSK (orthogonal FSK)	P_s	$\leq (M-1)Q\left(\sqrt{d_{\min}^2 \frac{\varepsilon_b}{N_0}}\right)$, Example 4.18c, Table 4.1
	d_{\min}^2	$\log_2(M)$, Table 4.1 on page 281
	ρ	See (2.245)
M-ary bi- orthogonal signals	P_s	$\leq (M-2)Q\left(\sqrt{d_{\min}^2 \frac{\varepsilon_b}{N_0}}\right) +$ $+Q\left(\sqrt{2d_{\min}^2 \frac{\varepsilon_b}{N_0}}\right)$, (5.53)
	d_{\min}^2	$\log_2(M)$ if $M \geq 4$, (5.51)
	ρ	$\rho_{M\text{-bi-ort}} = \rho_{M/2\text{-ort}} \cdot \frac{\log_2(M)}{\log_2(M/2)}$, (5.52)

Table 5.1: Symbol error probability and bandwidth efficiency results.

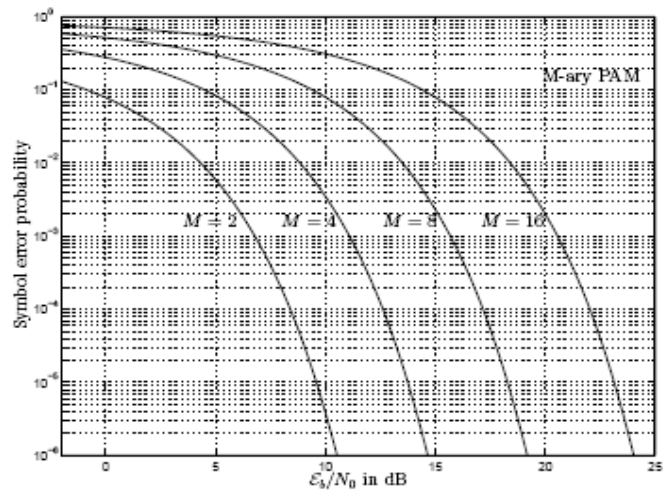

Figure 5.13: The symbol error probability for M-ary PAM, $M = 2, 4, 8, 16$, see Table 5.1. The specific assumptions are given in Subsection 2.4.1.1, and in Subsection 5.1.3.

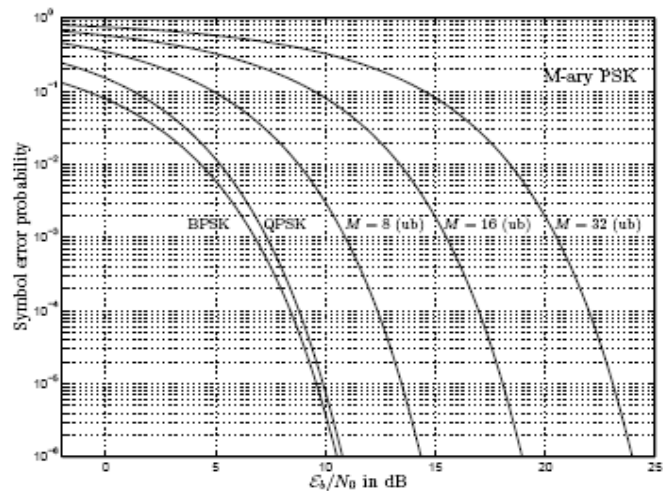

Figure 5.14: The symbol error probability for M-ary PSK, $M = 2, 4, 8, 16, 32$, see Table 5.1. In this figure upper bounds are denoted (ub). See also Subsection 5.1.5.

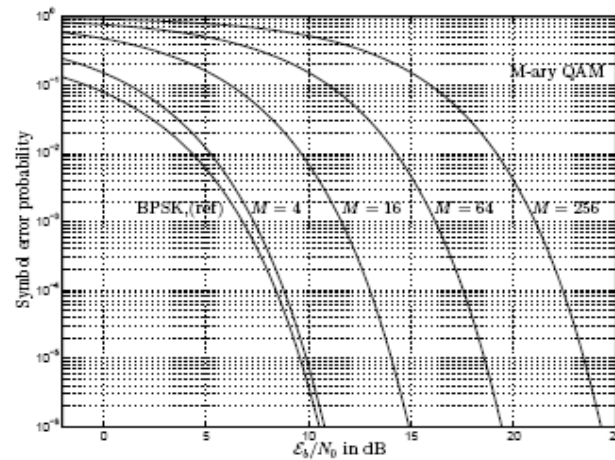

Figure 5.15: The symbol error probability for M-ary QAM, $M = 4, 16, 64, 256$, see Table 5.1. The specific assumptions are given in Subsection 2.4.5.1 and in Subsection 5.1.6. The bit error probability for BPSK is also given as a reference ($= Q(\sqrt{2\mathcal{E}_b/N_0})$).

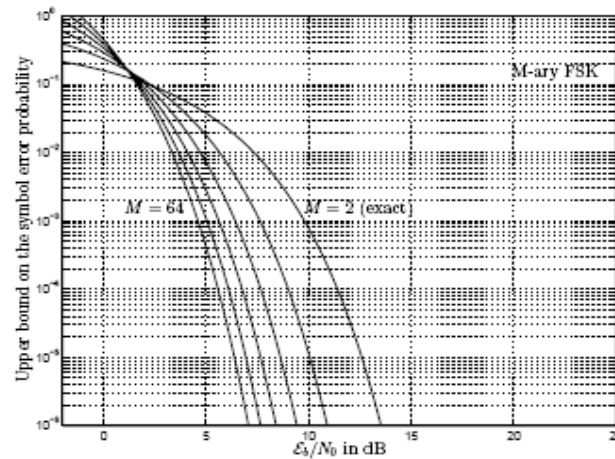

Figure 5.16: Upper bound (the union bound) on the symbol error probability for orthogonal equal energy M-ary FSK signal alternatives, $M = 2, 4, 8, 16, 32, 64$, see Table 5.1 and Example 4.18c. The result given for the binary case is exact ($= Q(\sqrt{\mathcal{E}_b/N_0})$).

5.2.2 Power and Bandwidth Efficiency

We saw in (5.60) that the information bit rate R_b is limited by d_{\min}^2 , c , P_z , N_0 and $P_{s,req}$. Let us divide both sides in (5.60) with the bandwidth W ,

$$\boxed{\rho \leq \frac{d_{\min}^2}{\mathcal{X}} \cdot \frac{P_z}{N_0 W} = \frac{d_{\min}^2}{\mathcal{X}} \cdot \mathcal{SNR}_r} \quad (5.61)$$

Note that the bandwidth efficiency ρ is limited by d_{\min}^2 , c , $P_{s,req}$, and by the **received signal-to-noise power ratio** $\mathcal{SNR}_r = P_z/N_0 W$ within the signal bandwidth W . The bandwidth W is the physical bandwidth defined on the

5.2.3 Shannon's Capacity Theorem

In Shannons capacity theorem, [54], [68], [20], [43], for the bandlimited flat ($|H(f)|^2 = \alpha^2$ within the bandwidth W) AWGN channel, the capacity \mathcal{C} for this channel is (in bits per second),

$$\boxed{\mathcal{C} = W \log_2 \left(1 + \frac{P_z}{N_0 W} \right) , [b/s]} \quad (5.62)$$

where W is the physical bandwidth measured on the positive frequency axis containing **all** the signal power. This remarkable theorem states that ([43], [68]): **There exists** at least one signal construction method that achieves an arbitrary small error probability, if the bit rate $R_b < \mathcal{C}$. If $R_b > \mathcal{C}$, then the error probability P_s is high for every possible signal construction method.

What happens with the capacity C if the bandwidth W increases to a very large value?

$$\mathcal{C} = W \log_2 \left(1 + \frac{\mathcal{P}_z}{N_0 W} \right), \text{ [b/s]} \quad (5.62)$$

$$\lim_{W \rightarrow \infty} \mathcal{C} = \lim_{W \rightarrow \infty} \frac{W}{\ln(2)} \ln \left(1 + \frac{\mathcal{P}_z}{N_0 W} \right) = \frac{\mathcal{P}_z}{N_0 \ln(2)} \quad (5.63)$$

$$\frac{\mathcal{C}}{W} = \log_2 \left(1 + \frac{\mathcal{P}_z}{N_0 W} \right) = \log_2 \left(1 + \frac{\mathcal{C}}{W} \cdot \frac{\mathcal{E}_b}{N_0} \right), \text{ [bps/Hz]}$$

or equivalently,

$$\frac{\mathcal{E}_b}{N_0} = \frac{2^{\mathcal{C}/W} - 1}{\mathcal{C}/W} \quad (5.64)$$

Since \mathcal{C} is the maximum bit rate, \mathcal{E}_b here represents the minimum average received energy per information bit, for a given \mathcal{P}_z , $\mathcal{P}_z = \mathcal{C}\mathcal{E}_b$.

$$\frac{\mathcal{P}_z}{N_0 W} = \frac{\mathcal{C}}{W} \cdot \frac{\mathcal{E}_b}{N_0} = 2^{\mathcal{C}/W} - 1 \quad (5.65)$$

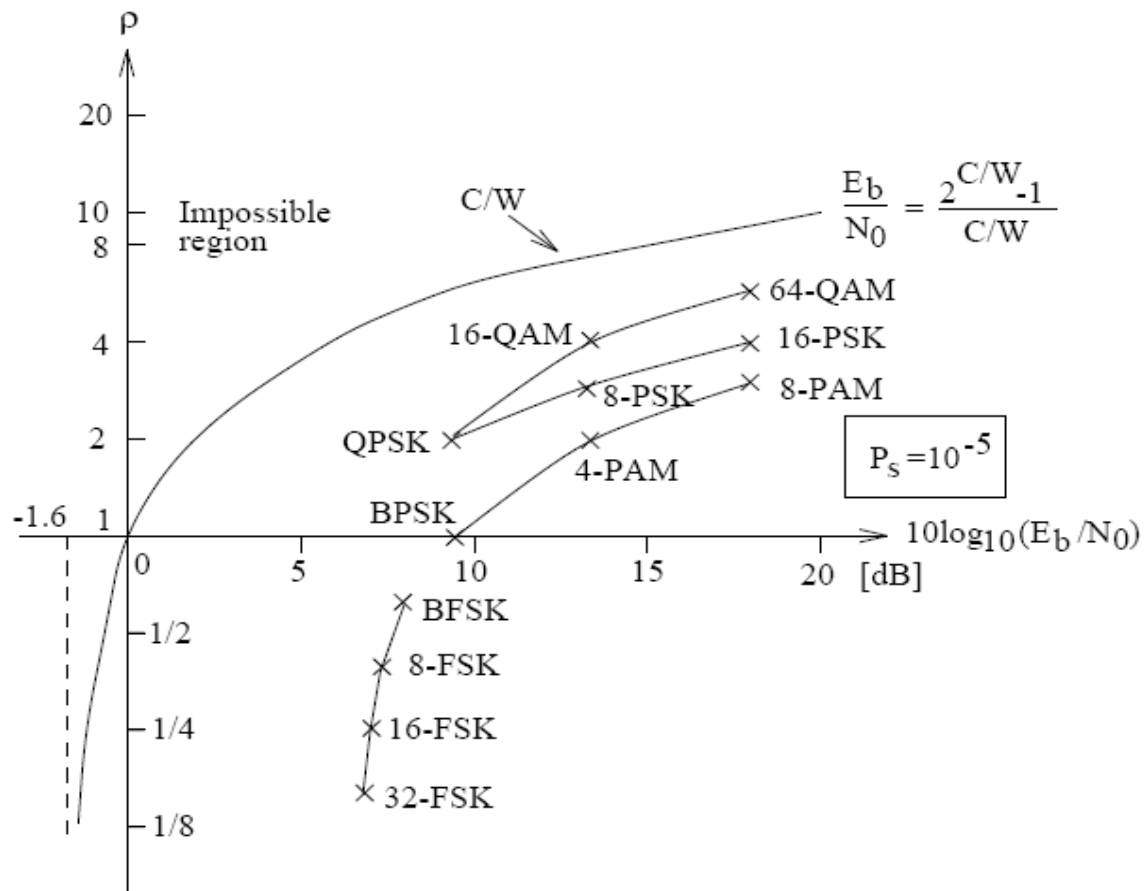

Figure 5.17: Sketch of the ρ versus E_b/N_0 performance for some of the schemes studied in this section. Reliable communication is not possible above the capacity curve (see (5.64)).

This result is of both practical and theoretical importance!

For a given amount of transmitted signal power,
and a given channel:

HOW DO WE MAXIMIZE THE BIT RATE?

5.2.3.1 Shannon Capacity for General $|H(f)|^2$ and $R_N(f)$

1. For a given average transmitted signal power P_{sent} , and channel quality function $q_{ch}(f) = |H(f)|^2/R_N(f)$, the parameter B below should first be determined,

$$P_{sent} = \int_{\Omega} \left(B - \frac{R_N(f)}{|H(f)|^2} \right) df \quad (5.68)$$

This is referred to as **“waterfilling”**!

2. The capacity C is then found as,

$$C = \int_{\Omega} \frac{1}{2} \log_2 \left(\frac{|H(f)|^2}{R_N(f)} \cdot B \right) df \quad (5.70)$$

EXAMPLE 5.20

Assume that $|H(f)|^2$ is,

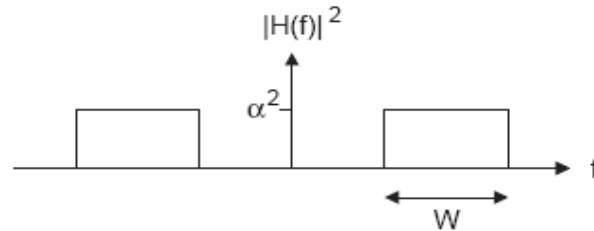

and that $R_N(f) = N_0/2$ for all f . Calculate the capacity of this channel if the average transmitted signal power is P_{sent} .

Solution:

The figure below shows $R_N(f)/|H(f)|^2$, and the parameter B .

Step 1:

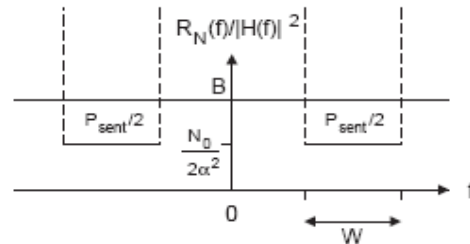

From (5.68)–(5.69) we find that the value of B is determined by the equality

$$P_{sent} = \left(B - \frac{N_0}{2\alpha^2} \right) 2W$$

and B is found to be

$$B = \frac{P_{sent}}{2W} + \frac{N_0}{2\alpha^2}$$

Step 2:

$$C = \frac{W}{2} \log_2 \left(\frac{\alpha^2}{N_0/2} \left(\frac{P_{sent}}{2W} + \frac{N_0}{2\alpha^2} \right) \right) \cdot 2 = W \log_2 \left(1 + \frac{\alpha^2 P_{sent}}{N_0 W} \right)$$

Problem 5.30

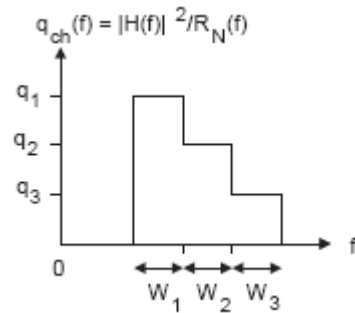

The algorithm is referred to as “water filling” type of algorithm, and it is illustrated in the figure below.

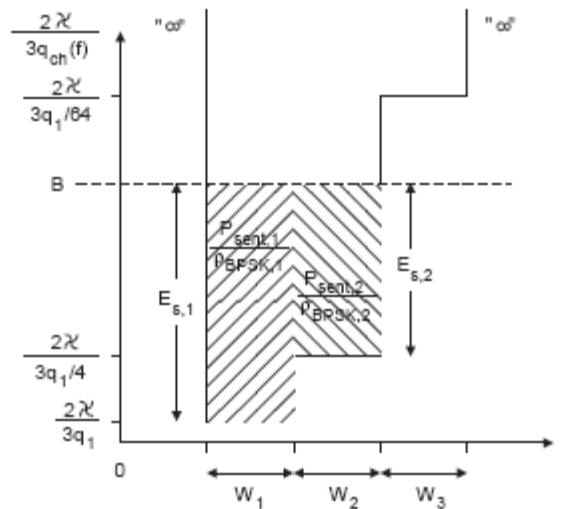

Waterfilling: Connection to OFDM?

5.4.1 Diversity: Introductory Concepts

”Dont put all eggs in the same basket”

Assume that each message is sent in N dimensions (time/frequency/space etc)

$$s_j(t) = \sum_{n=1}^N s_{j,n} \phi_n(t) , \quad j = 0, 1, \dots, M - 1 \quad (5.79)$$

Assume independent attenuations in each dimension:

$$r(t) = z_j(t) + N(t) = \sum_{n=1}^N \alpha_n s_{j,n} \phi_n(t) + N(t) \quad (5.80)$$

$$z_j = \begin{pmatrix} \alpha_1 & & & \mathbf{0} \\ & \alpha_2 & & \\ & & \ddots & \\ \mathbf{0} & & & \alpha_N \end{pmatrix} \begin{pmatrix} s_{j,1} \\ \vdots \\ s_{j,N} \end{pmatrix} = \begin{pmatrix} \alpha_1 s_{j,1} \\ \vdots \\ \alpha_N s_{j,N} \end{pmatrix} \quad (5.81)$$

Note: It can be very ”dangerous” to use only one (i.e. N=1) dimension!

We now introduce the concept of **diversity** in connection with Figure 5.21 and (5.80). Diversity is often used, e.g., for so-called **fading** channels (randomly varying signal levels, see Chapter 9), to improve the error probability. *Diversity can be obtained by spreading the same message over many dimensions.* Hence, in the receiver, message m_j has coordinates in, say L , dimensions. Let p denote the probability that a received signal is seriously distorted in any single dimension. The basic idea with diversity is that the probability for large distortions in **all** dimensions ($\approx p^L$) is significantly lower than p . Observe that this requires that the distortions in each dimension are essentially independent. So, intuitively speaking, there is a high probability that a few message carrying coordinates “survive” the channel without too much damage, and it is these coordinates that the receiver bases its decision on. Compare with Figure 5.21b,c assuming some of the α_n 's are close to zero. It should also be mentioned here that there is a close relationship between the concept of diversity and the concept of **coding**.

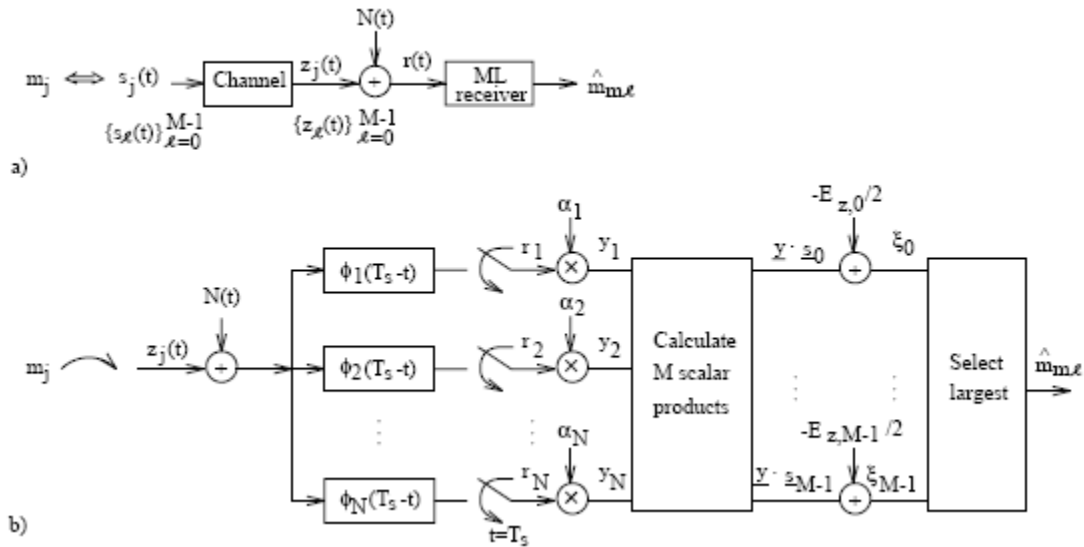

Figure 5.21:

a) The digital communication system; b) The ML receiver, assuming (5.80);

Observe that the channel attenuations are used as *multipliers in the receiver* according to the receiver structure in figure 5.8a on page 341!

EXAMPLE 5.23

Assume a binary communication system with equiprobable antipodal signal alternatives,

$$s_1(t) = -s_0(t) = \sum_{k=1}^K g_k(t), \quad 0 \leq t \leq T_b$$

Let $E_{b, \text{sent}}$ denote the average transmitted energy per information bit, i.e. $E_{s_1} = E_{s_0} = E_{b, \text{sent}}$. It is also assumed that the individual pulses $g_k(t)$ are such that

$$\int_0^{T_b} g_i(t)g_j(t) dt = \begin{cases} E_{b, \text{sent}}/K & , \quad i = j \\ 0 & , \quad i \neq j \end{cases}$$

We can therefore define (sent) basis functions as,

$$\phi_k(t) = \frac{g_k(t)}{\sqrt{E_{b, \text{sent}}/K}}, \quad k = 1, 2, \dots, K$$

and the signal energy $E_{b, \text{sent}}/K$ is sent in each of the K dimensions.

Observe that the situation studied in this example applies to several kinds of diversity, e.g., time- and/or frequency-diversity, depending on how the pulses $g_k(t)$ are chosen.

The communication channel is assumed to be such that the received signal alternatives are,

$$z_1(t) = -z_0(t) = \sum_{k=1}^K \alpha_k g_k(t) = \sum_{k=1}^K \underbrace{\alpha_k \sqrt{\frac{E_{b, \text{sent}}}{K}}}_{z_{1,k}} \phi_k(t)$$

and they are disturbed by AWGN $N(t)$ with power spectral density $R_N(f) = N_0/2$. Note that the channel coefficients $\{\alpha_k\}_{k=1}^K$ multiply the signal in each dimension, respectively. The ideal ML receiver is used and it is assumed that perfect estimates of the channel coefficients are available to the receiver.

- Assume that the channel parameters $\{\alpha_k\}_{k=1}^K$ are known to the receiver. Determine an expression of P_b that includes $E_{b, \text{sent}}$.
- Suggest a receiver structure for the case in a).

Solution:

a)

$$P_b = Q\left(\sqrt{2E_b/N_0}\right)$$

$$\varepsilon_b = \frac{E_{z_0} + E_{z_1}}{2} = E_{z_0} = E_{z_1} = \sum_{k=1}^K z_{j,k}^2 = \frac{E_{b, \text{sent}}}{K} \sum_{k=1}^K \alpha_k^2$$

Hence, we obtain that

$$P_b = Q\left(\sqrt{\frac{2E_{b, \text{sent}}}{N_0 K} \sum_{k=1}^K \alpha_k^2}\right)$$

Note that here a K -fold diversity is obtained, in the sense that signal energy from all K dimensions (or “sub-channels”) is efficiently collected and used in the decision process.

Note also that

$$D_{s_1, s_0}^2 = 4E_{b, \text{sent}}$$

$$D_{z_1, z_0}^2 = 4E_z = \frac{4E_{b, \text{sent}}}{K} \sum_{k=1}^K \alpha_k^2 = \frac{D_{s_1, s_0}^2}{K} \sum_{k=1}^K \alpha_k^2$$

b) From Figure 4.10 on page 247 we obtain the receiver structure below (the constant 2 is ignored in the correlation below),

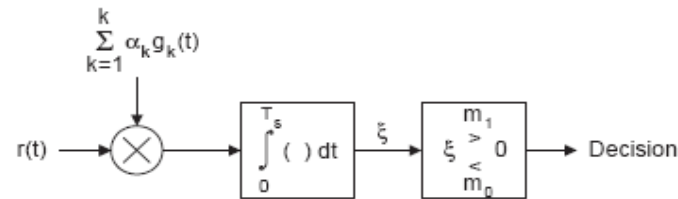

An equivalent receiver structure is also shown below,

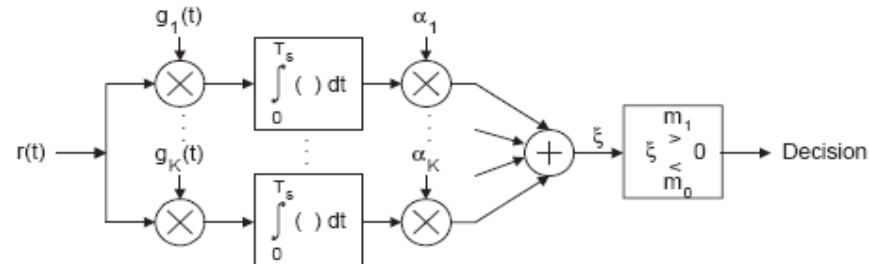

MIMO MODEL

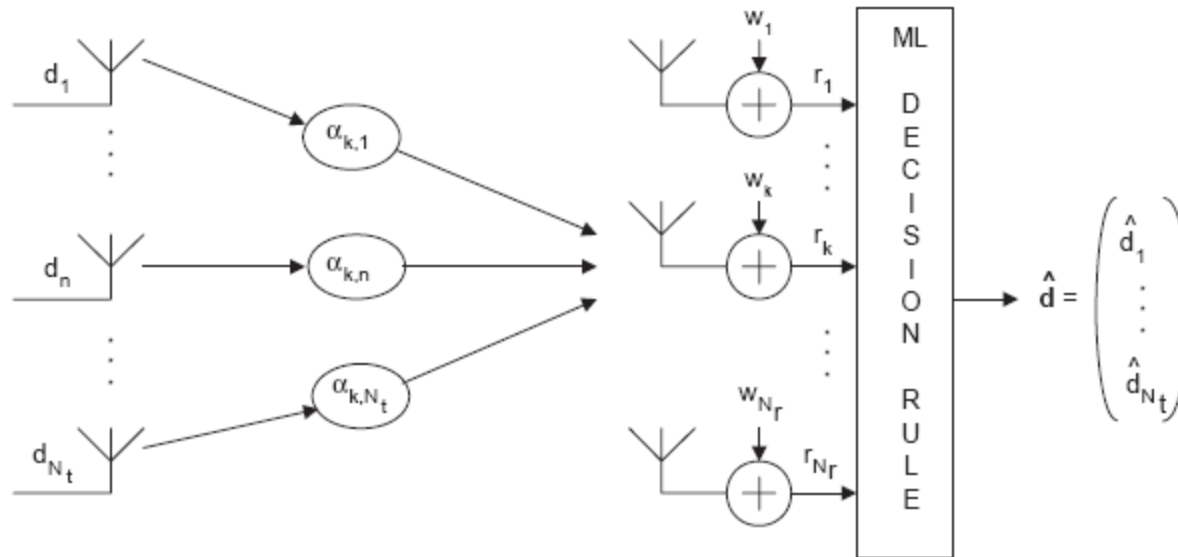

$$r_k = \sum_{n=1}^{N_t} \alpha_{k,n} d_n + w_k$$

$$\mathbf{r} = \begin{pmatrix} r_1 \\ \vdots \\ r_{N_r} \end{pmatrix} = \mathbf{A} \begin{pmatrix} d_1 \\ \vdots \\ d_{N_t} \end{pmatrix} + \begin{pmatrix} w_1 \\ \vdots \\ w_{N_r} \end{pmatrix} = \mathbf{A} \mathbf{d} + \mathbf{w}$$

Assume, e.g., that: $N_t=1$ and data symbol d_1 is binary: $+A$ or $-A$

5.4.1.1 An Example Illustrating Diversity Gains

Here we study the case when the channel parameters $\{\alpha_k\}_{k=1}^K$ have the following properties:

- They are assumed to be independent random variables, and only two values are possible for each α_k .
- Each α_k takes the value α_G (“Good”) with probability P_G , and the value α_B (“Bad”) with probability $P_B = 1 - P_G$.

$$\begin{aligned}\mathcal{E}_b &= E \left\{ \frac{E_{b, \text{sent}}}{K} \sum_{k=1}^K \alpha_k^2 \right\} = E_{b, \text{sent}} E \{ \alpha_k^2 \} = \\ &= E_{b, \text{sent}} (\alpha_G^2 P_G + \alpha_B^2 (1 - P_G))\end{aligned}\tag{5.84}$$

$$\begin{aligned}P_b &= E \left\{ P_{b|\{\alpha_k\}_{k=1}^K} \right\} = E \left\{ Q \left(\sqrt{\frac{2E_{b, \text{sent}}}{N_0 K} \sum_{k=1}^K \alpha_k^2} \right) \right\} = \\ &= E \left\{ Q \left(\sqrt{\frac{2}{\alpha_G^2 P_G + \alpha_B^2 (1 - P_G)} \cdot \frac{\mathcal{E}_b}{N_0} \cdot \frac{1}{K} \sum_{k=1}^K \alpha_k^2} \right) \right\}\end{aligned}\tag{5.85}$$

$$P_b = \sum_{n=0}^K \binom{K}{n} P_G^n (1 - P_G)^{K-n}$$

$$Q \left(\sqrt{\frac{2}{P_G + (1 - P_G)\alpha_B^2/\alpha_G^2}} \cdot \frac{n + (K - n)\alpha_B^2/\alpha_G^2}{K} \cdot \frac{\mathcal{E}_b}{N_0} \right)$$

(5.90)

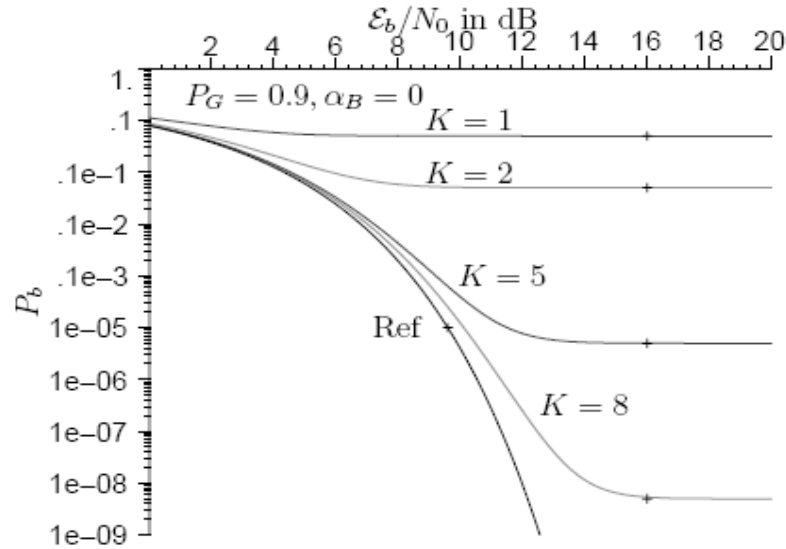

Figure 5.22: The bit error probability versus \mathcal{E}_b/N_0 for the case $P_G = 0.9$ and $\alpha_B = 0$, with $K = 1, 2, 5, 8$.

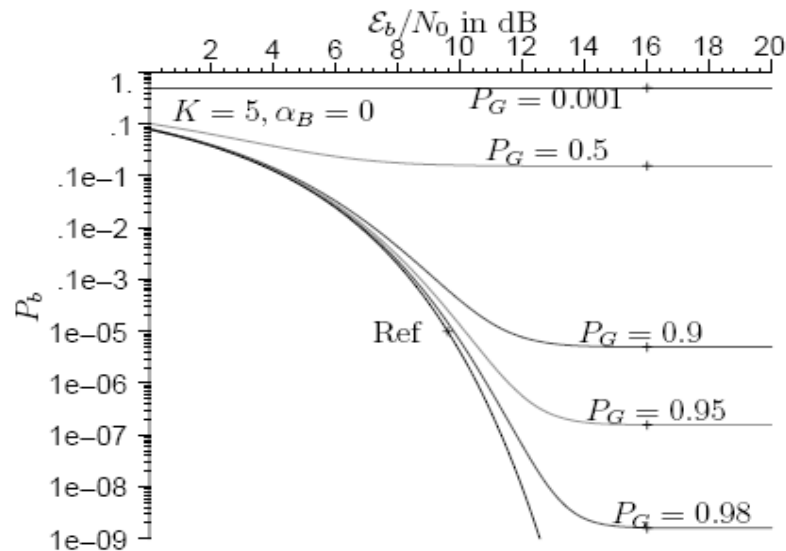

Figure 5.23: The bit error probability versus \mathcal{E}_b/N_0 for the case $K = 5$ and $\alpha_B = 0$, with $P_G = 0.001, 0.5, 0.9, 0.95, 0.98$.

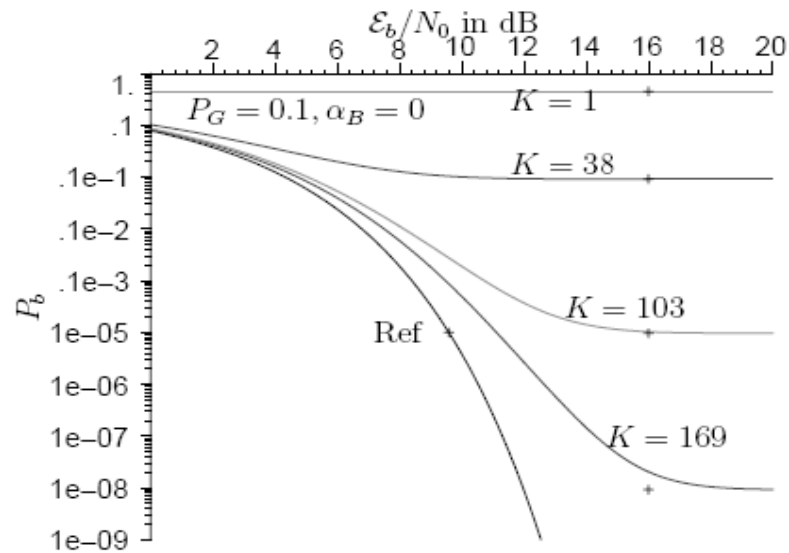

Figure 5.24: The bit error probability versus \mathcal{E}_b/N_0 for the case $P_G = 0.1$ and $\alpha_B = 0$, with $K = 1, 38, 103, 169$.

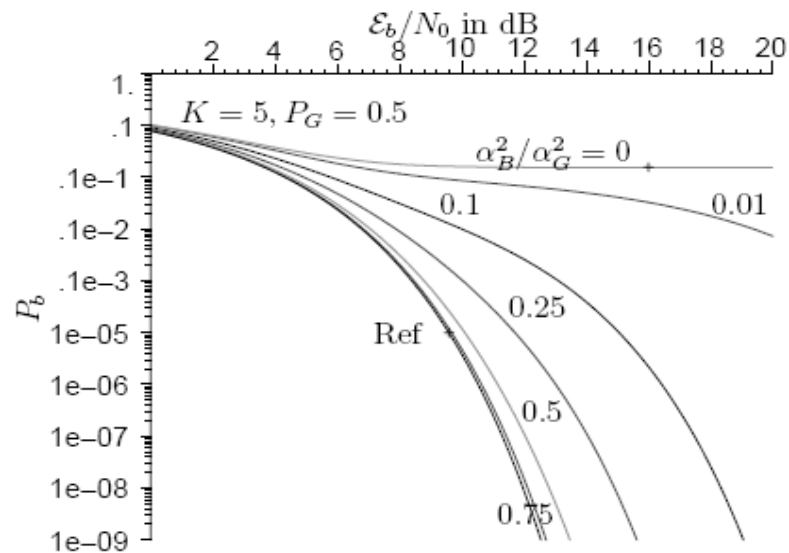

Figure 5.25: The bit error probability versus \mathcal{E}_b/N_0 for the case $K = 5$ and $P_G = 0.5$, with $\alpha_B^2/\alpha_G^2 = 0, 0.01, 0.1, 0.25, 0.5, 0.75$.

5.34 Consider a communication system where N_t M-ary QAM signals are sent simultaneously (from N_t antennas). The n :th transmitted M-ary QAM signal is denoted $s_n(t)$,

$$s_n(t) = A(n)g(t) \cos(\omega_c t) - B(n)g(t) \sin(\omega_c t) \quad (5.133)$$

for $n = 1, 2, \dots, N_t$. Note that the same carrier frequency is used for all N_t transmitted QAM signals!

The MIMO model is illustrated in the figure below,

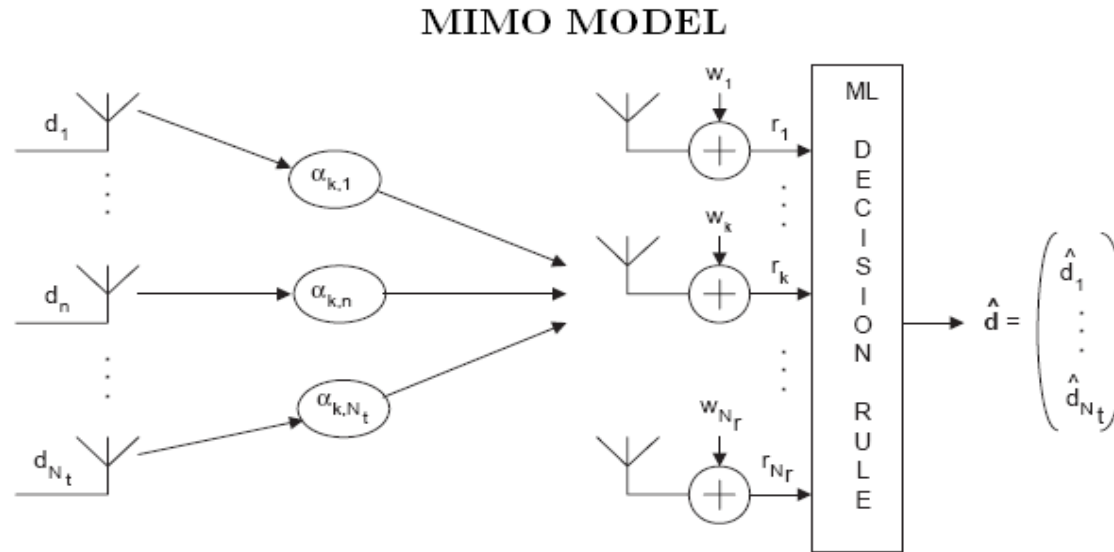

$$r_k = \sum_{n=1}^{N_t} \alpha_{k,n} d_n + w_k$$

$$\mathbf{r} = \begin{pmatrix} r_1 \\ \vdots \\ r_{N_r} \end{pmatrix} = \mathbf{A} \begin{pmatrix} d_1 \\ \vdots \\ d_{N_t} \end{pmatrix} + \begin{pmatrix} w_1 \\ \vdots \\ w_{N_r} \end{pmatrix} = \mathbf{A} \mathbf{d} + \mathbf{w}$$

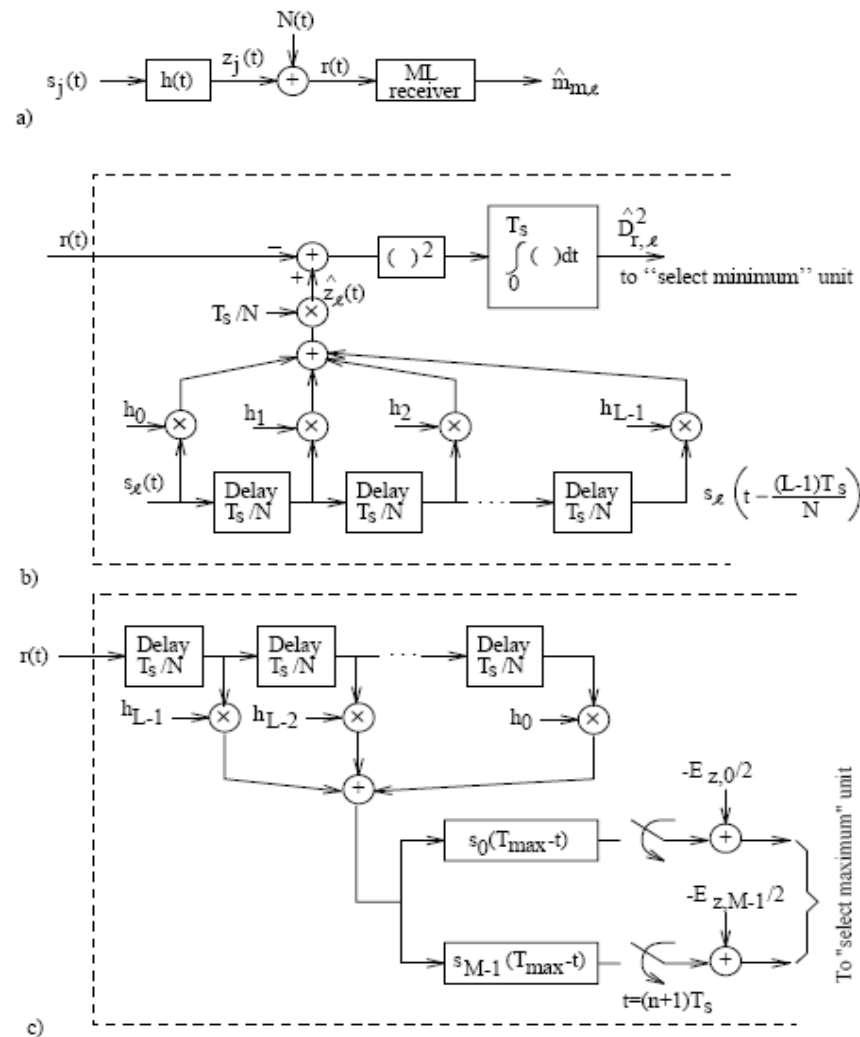

Figure 5.26:

- a) The filtered channel model. b) Generation of the decision variable $\hat{D}_{r,\ell}^2$ using an L -ray approximation approach (delayed reference receiver structure). c) An alternative receiver structure based on (5.96) (RAKE receiver structure).

5.4.4 Noncoherent Detection of M-ary FSK Signals

In this subsection noncoherent ML detection of equally likely, equal energy orthogonal M -ary FSK signals in AWGN is considered. Hence, it is here assumed that,

$$r(t) = z_j(t) + N(t) = \sqrt{2E/T_s} \cos(\omega_j t + \nu_j) + N(t), \quad 0 \leq t \leq T_s \quad (5.104)$$

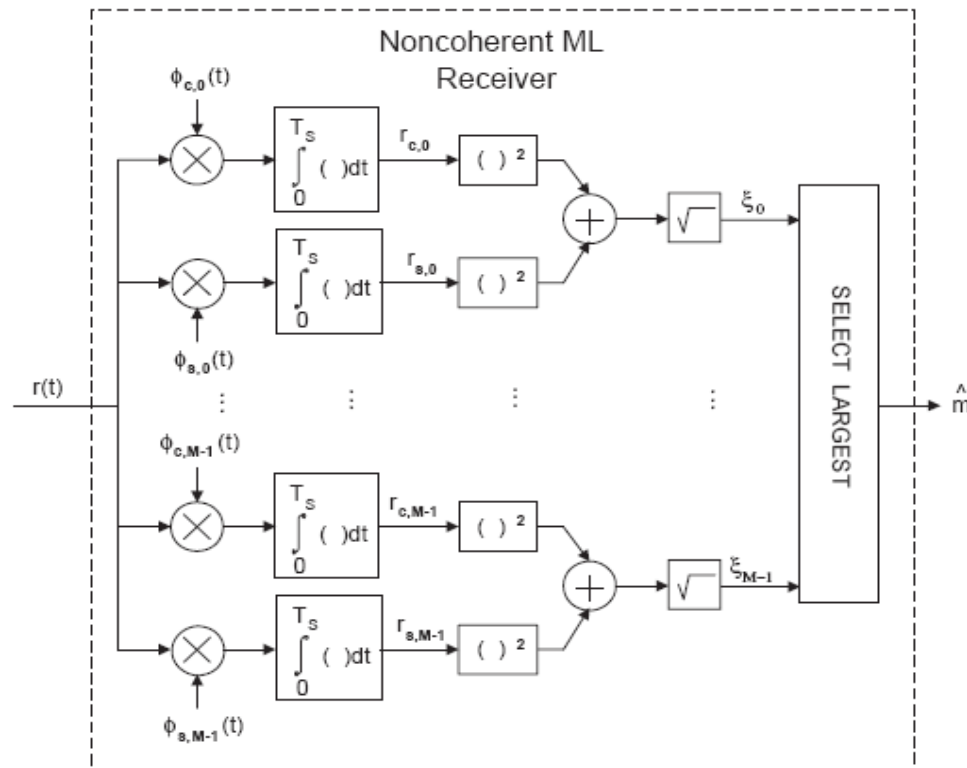

Figure 5.28: A correlator implementation of the noncoherent ML (symbol) receiver for equally likely, equal energy, orthogonal M -ary FSK signals in AWGN.

If $M = 2$, then the bit error probability for the receiver in Figure 5.28 equals,

$$P_b = \frac{1}{2} e^{-\mathcal{E}_b/2N_0}, \quad M = 2 \quad (5.109)$$

5.4.6 Additive Colored Gaussian Noise

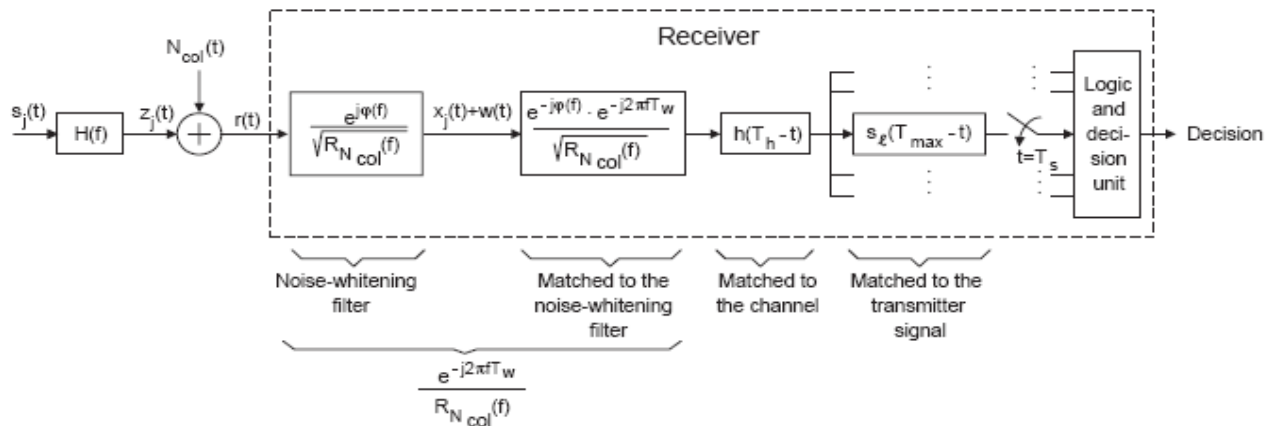

Figure 5.29: A possible receiver structure for detection of signals in colored noise $N_{col}(t)$.

$$R_{N_{col}}(f) = \frac{N_0}{2} + R_u(f) \quad (5.127)$$