

ETSF15

Analog/Digital

Stefan Host



Physical layer

- Analog vs digital
 - Sampling, quantisation, reconstruction
- Modulation
 - Represent digital data in a continuous world
- Disturbances
 - Noise and distortion
- Synchronization
 - Synchronization to signal or between nodes
- Digital data processing
 - Information

Data vs Signal vs Information

- **Data:** Static representation of information
- **Signal:** Dynamic representation of information
- **Information:** Information content in data or signal

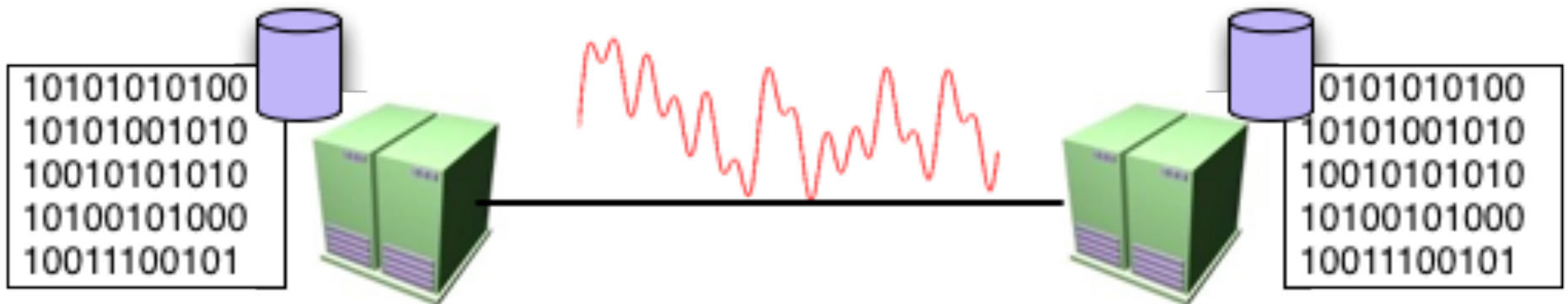

Analog vs Digital

Analog

- Continuous time and amplitude signal
- Electrical/optical domain

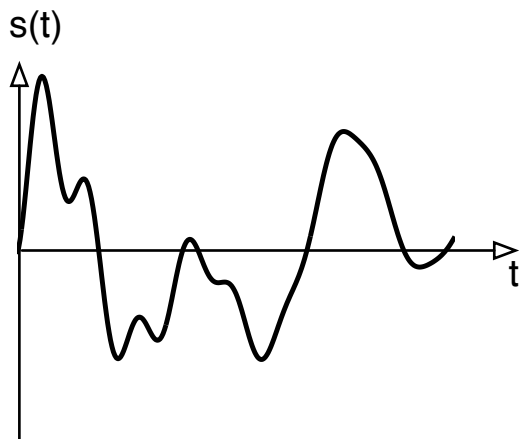

Digital

- Discrete time and amplitude
- Often binary representation

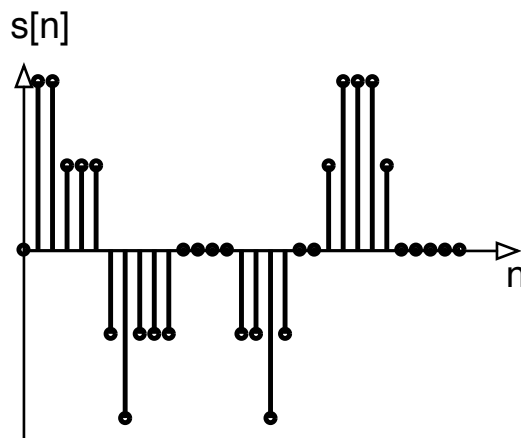

```
10101010111101000100111010
01010101001111010010001001
01101000100011101100010010
11100010101000001000101111
11010010101001001001000101
00101010010010010001010101
00101010101010010100001010
01011111001011010100101001
01101010100101110110011010
```

Digitalization of analog signals

Performed in three steps:

1. Sampling: Discretization in time
2. Quantization: Discretization in amplitude
3. Encoding: Binary representation of amplitude levels

In practice:

- ADC: Analog to Digital Converter
- DAC: Digital to Analog Converter

Sampling

- The process of discretizing time of a continuous signal.
$$s[n] = s(nT_s)$$
- Sample time: T_s
- Sample frequency:
$$F_s = 1/T_s$$
- Loose information about time

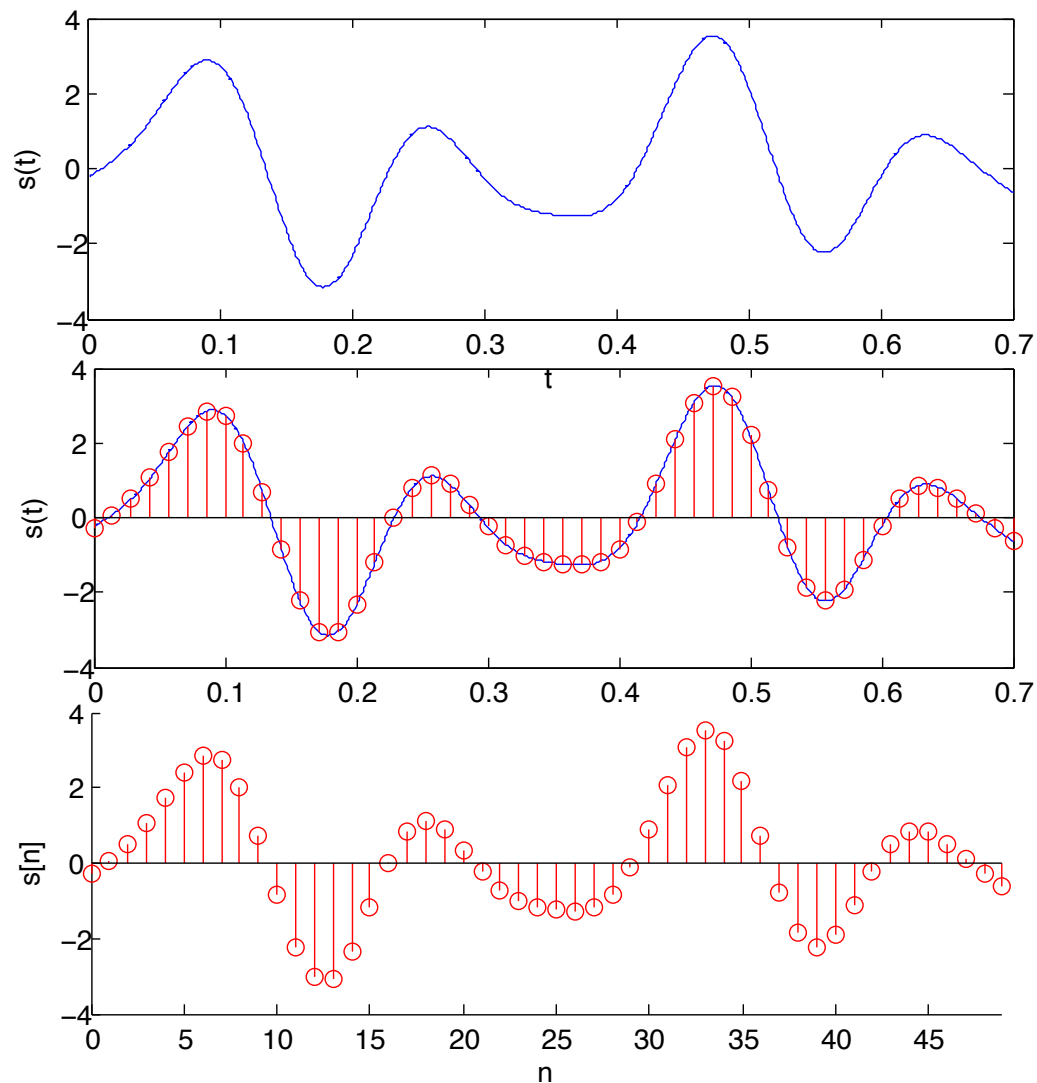

Shannon-Nyquist Sampling Theorem

- If $s(t)$ is a band limited signal with highest frequency component F_{max} , then $s(t)$ is uniquely determined by the samples $s[n] = s(nT_s)$ if and only if

$$F_s = \frac{1}{T_s} \geq 2F_{max}$$

- The signal can be (perfectly) reconstructed with

$$s(t) = \sum_{n=-\infty}^{\infty} s[n] \operatorname{sinc} \left(\frac{t - nT_s}{T_s} \right)$$

- $F_s/2$ is the Nyquist frequency and $2F_{max}$ the Nyquist rate

Reconstruction Example

$$y(t) = \sin\left(2\pi\frac{1}{7}t\right),$$

$$F_s = 1 \text{ Hz}$$

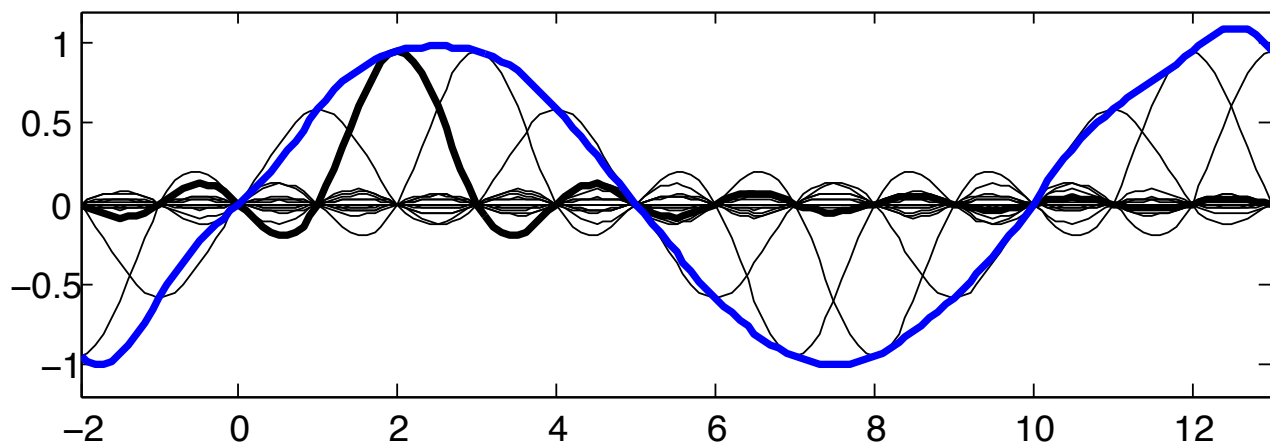
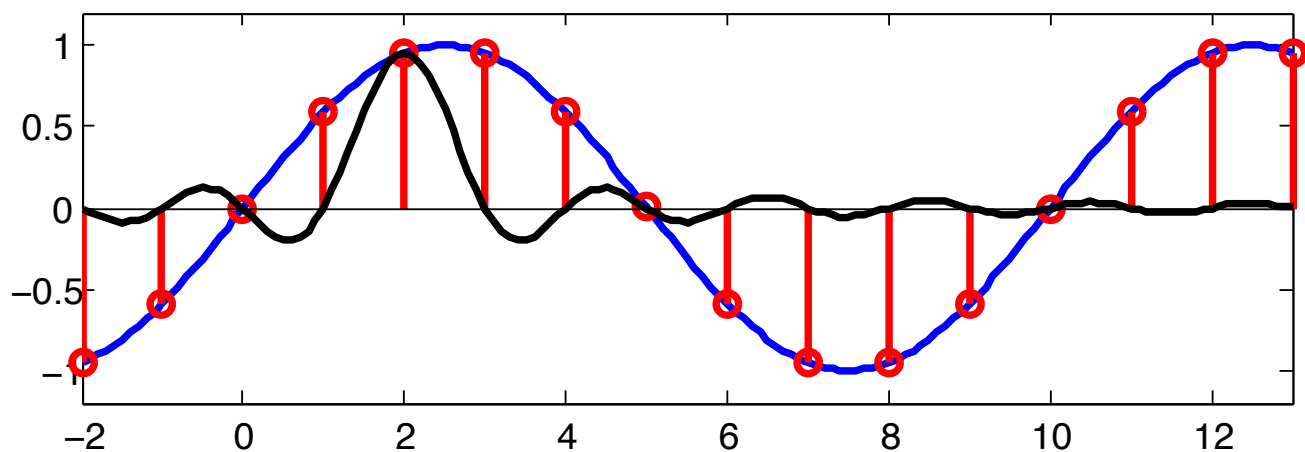

Aliasing

$$y(t) = \cos(2\pi 7t)$$

$$F_s = 10 \text{ Hz}$$

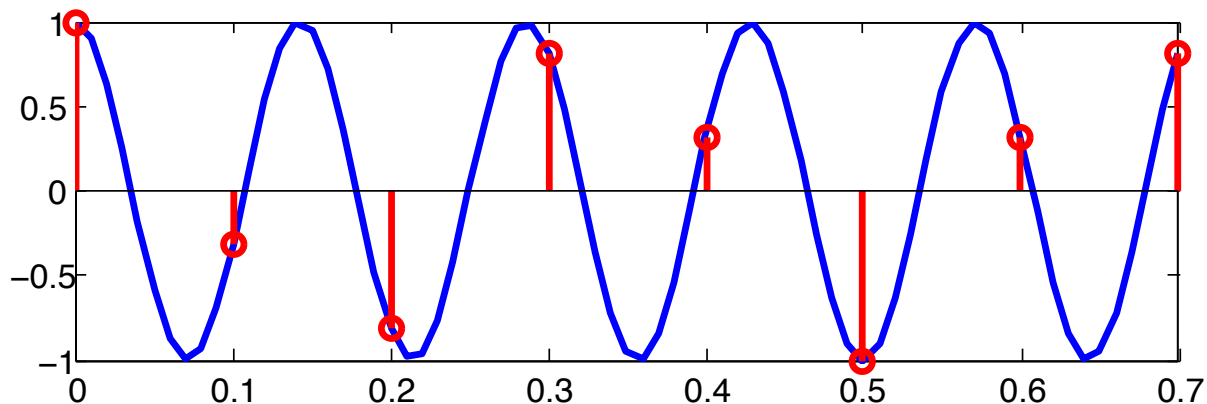

Reconstruction to lowest possible frequency

Reconstruct freq: $f_{rec} = f + kF_s$ s.t. $-F_s/2 \leq f_{rec} \leq F_s/2$

$$y(t) = \cos(2\pi 3t)$$

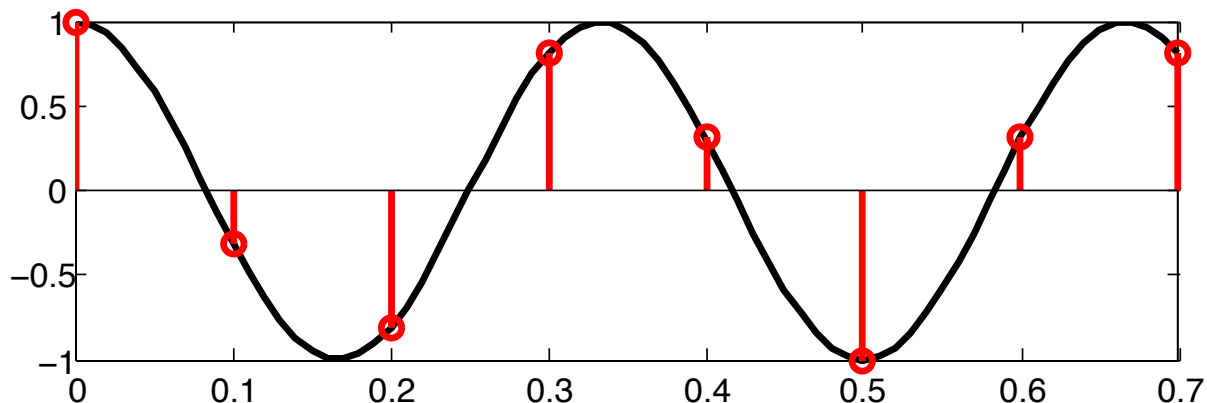

Sampling theorem proof

Two important transforms

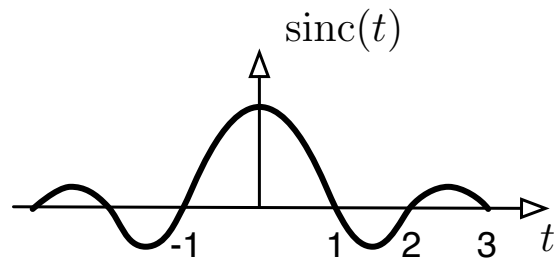

\mathcal{F}

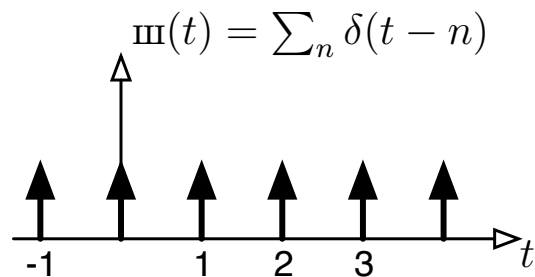
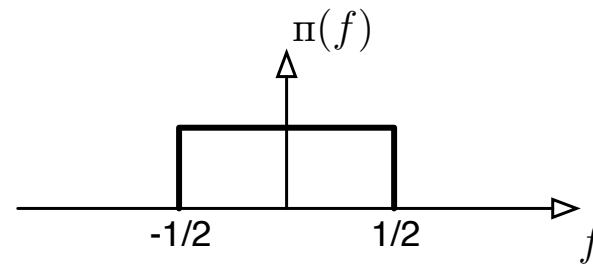

\mathcal{F}

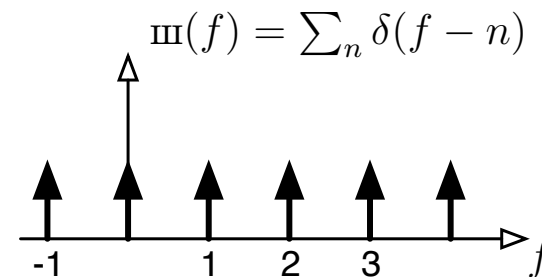

Sampling theorem proof

Mathematical description of sampling

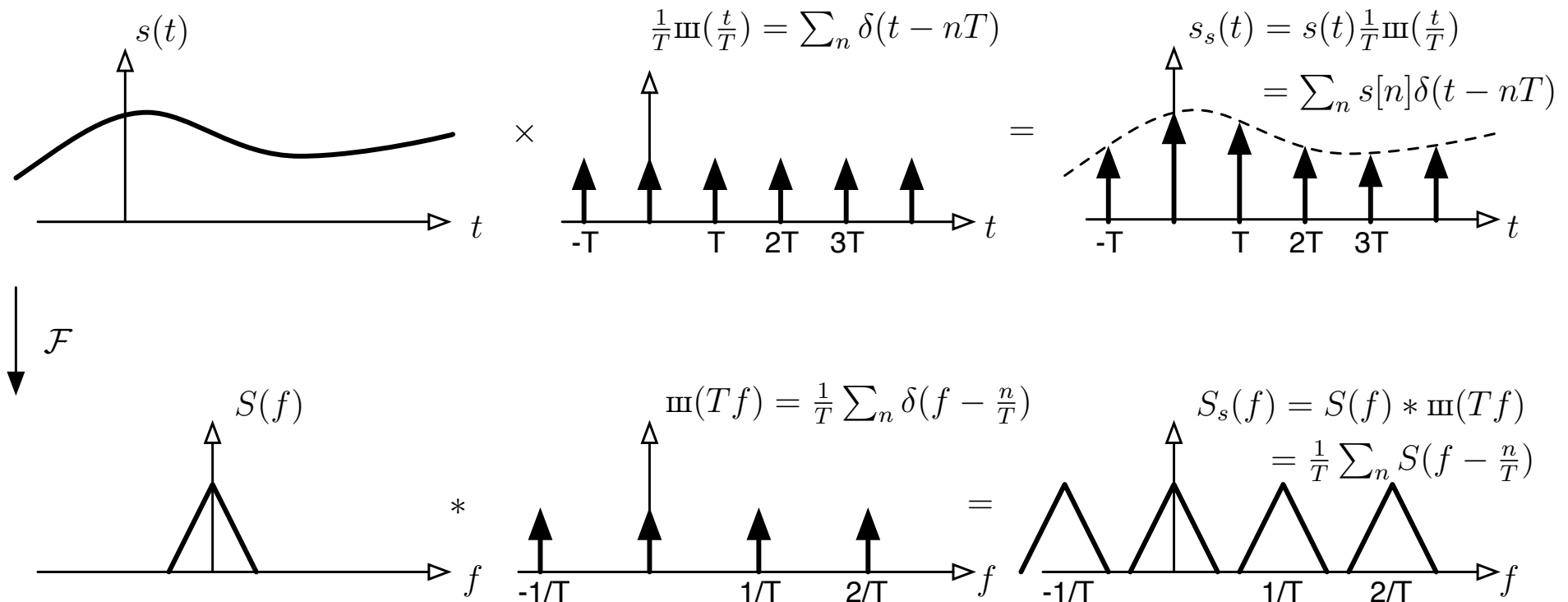

Sampling theorem proof

Reconstruction

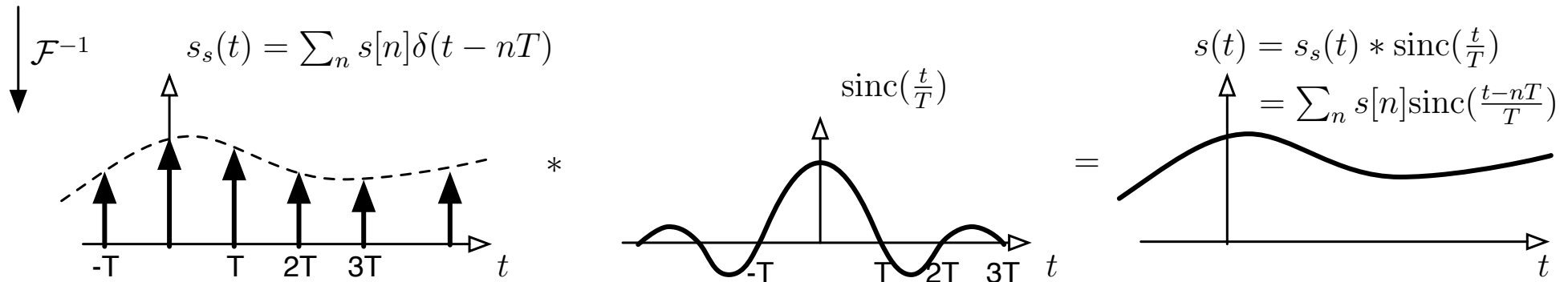
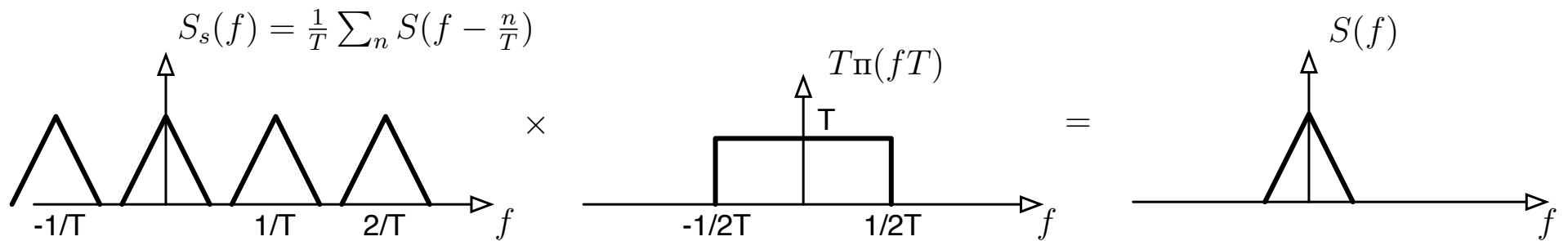

Sampling theorem

Aliasing

- Let $F_s < 2F_{\max}$

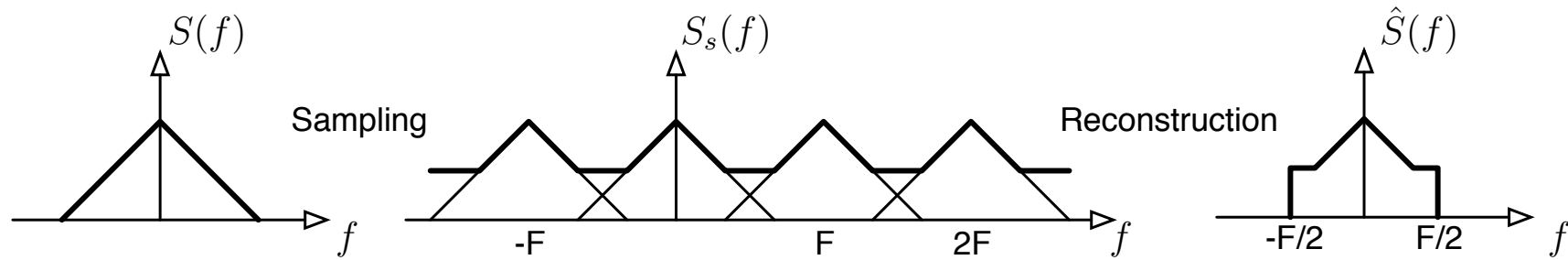

Example

$$y(t) = \cos(2\pi 7t) \rightarrow Y(f) = \frac{1}{2}(\delta(f + 7) + \delta(f - 7))$$

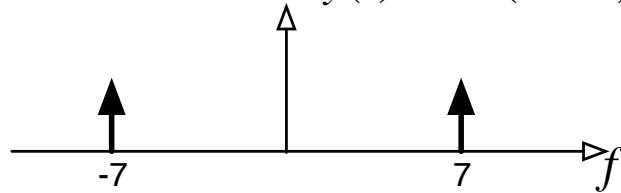

Sampling with $F_s = 10$ Hz

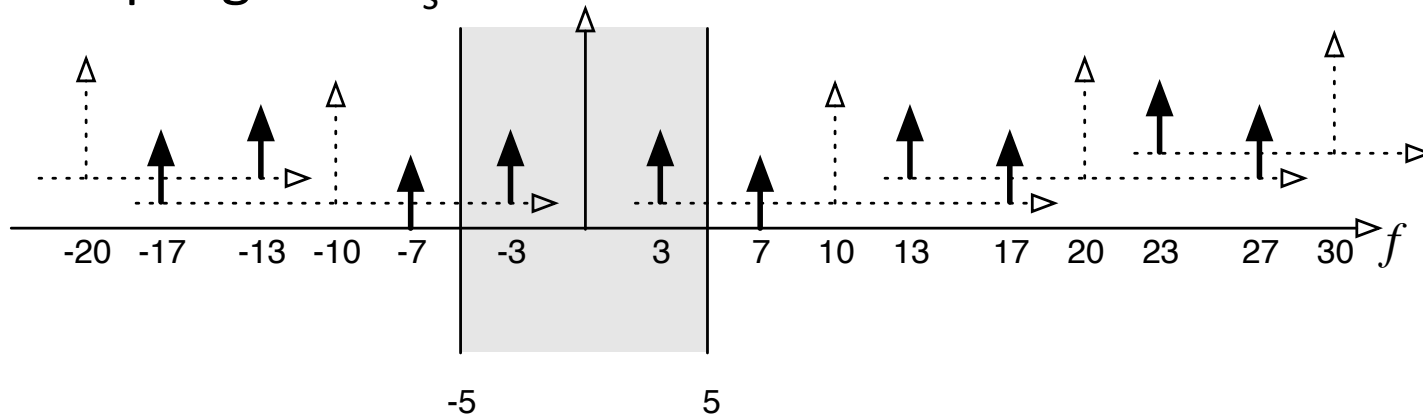

Reconstruct in $[-F_s/2, F_s/2]$: $\hat{Y}(f) = \frac{1}{2}(\delta(f + 3) + \delta(f - 3)) \rightarrow \hat{y}(t) = \cos(2\pi 3t)$

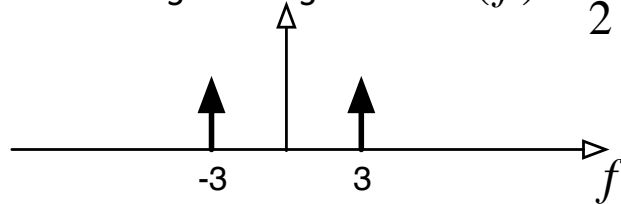

Quantization

- Uniform quantization for k bits
- $M=2^k$ equidistant levels
- Represent sample with k bits

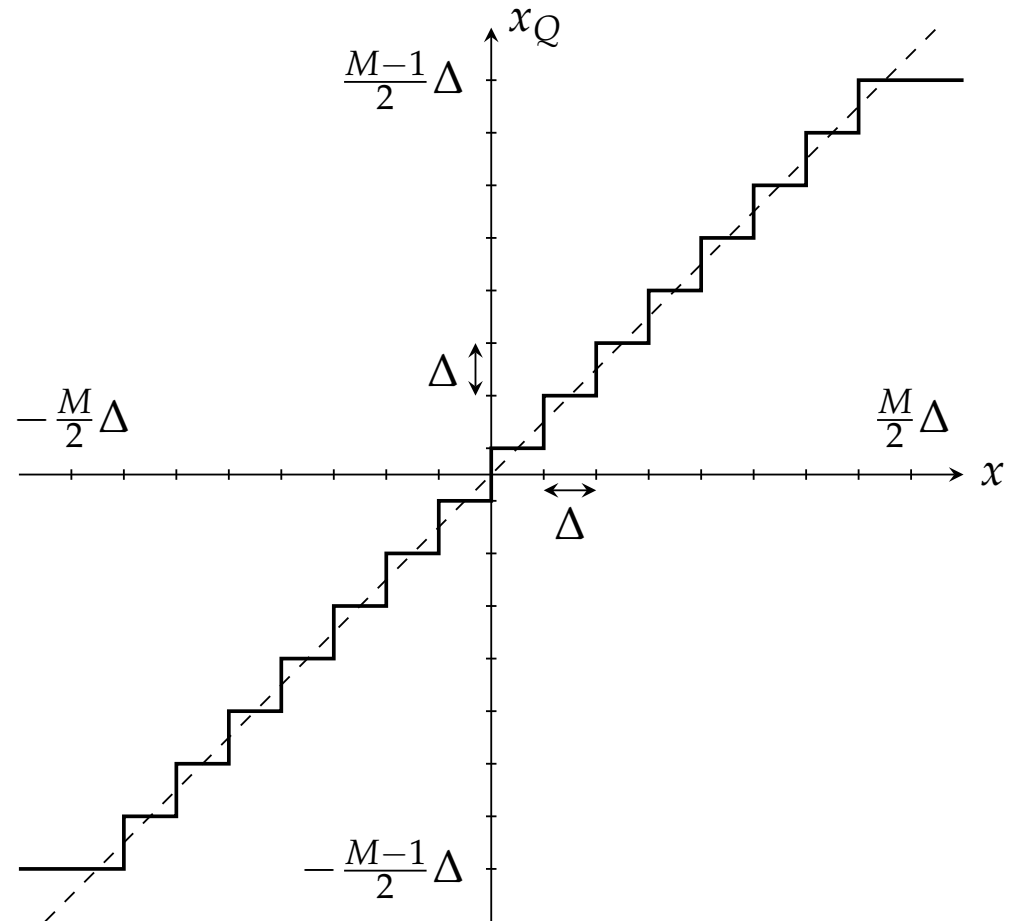

Encoding

- Representation of quantized samples in bits

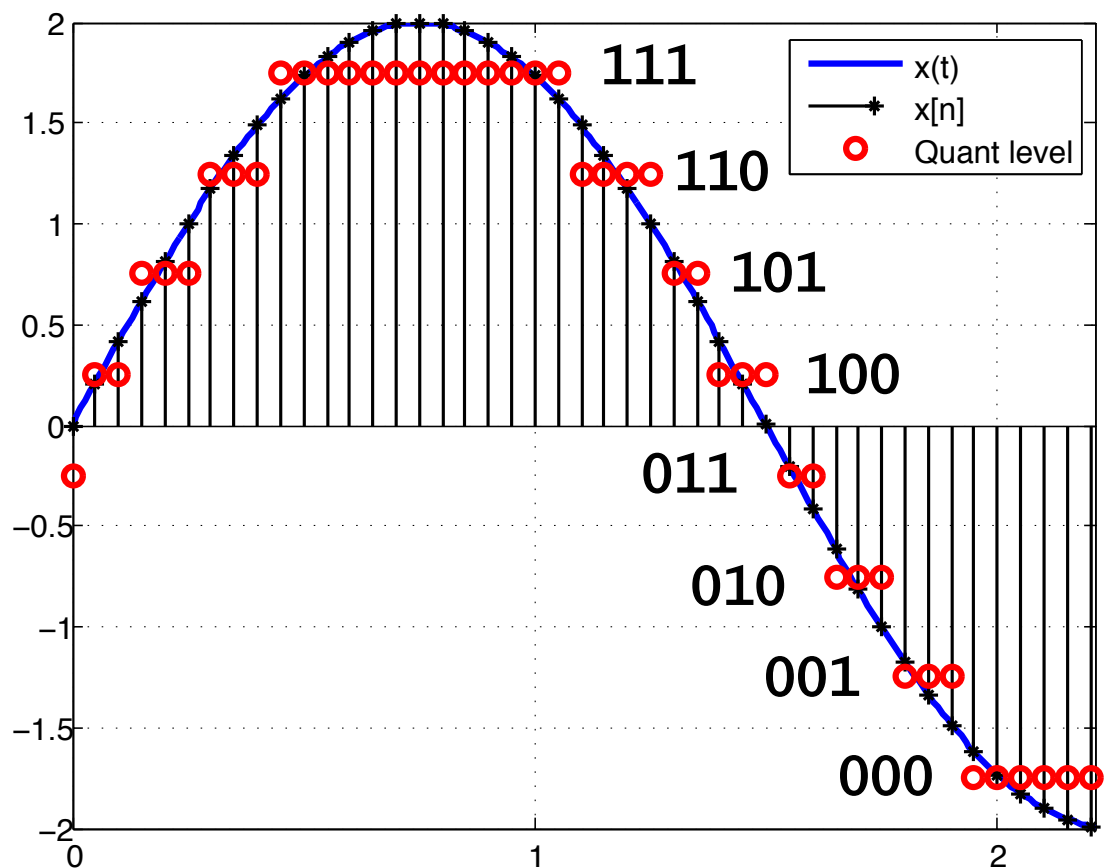

$x=01110010010110110111111111...$

Quantisation distortion

- Distortion (noise):

$$d(x, x_Q) = (x - x_Q)^2$$

- Average distortion for uniform input:

$$E\left[(X - X_Q)^2\right] = \int_{-\Delta/2}^{\Delta/2} x^2 \frac{1}{\Delta} dx = \frac{\Delta^2}{12}$$

- Signal to quantisation noise ratio

$$SQNR = \frac{E[X^2]}{E\left[(X - X_Q)^2\right]} = \frac{(M\Delta)^2 / 12}{\Delta^2 / 12} = M^2 = 2^{2k}$$

$$SQNR_{dB} = 10 \log 2^{2k} = k \cdot 6dB$$

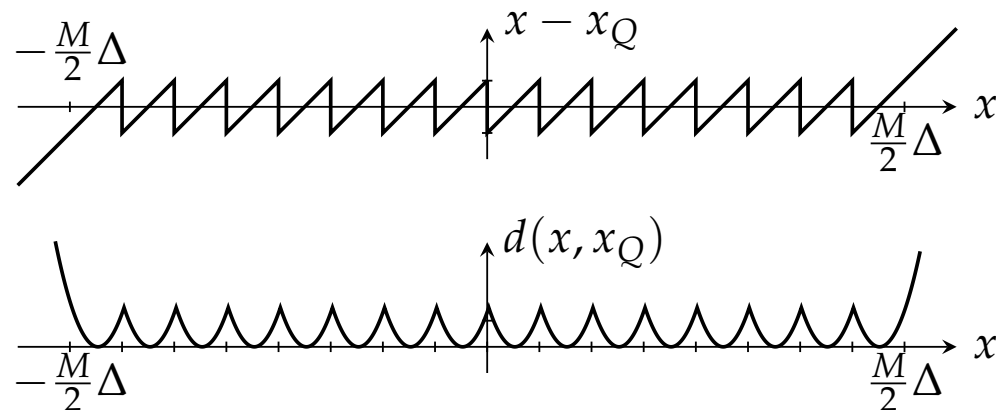

Delta modulation

- Represent change in amplitude with 1 bit
 - 1: +1
 - 0: -1
- Must use higher sampling rate

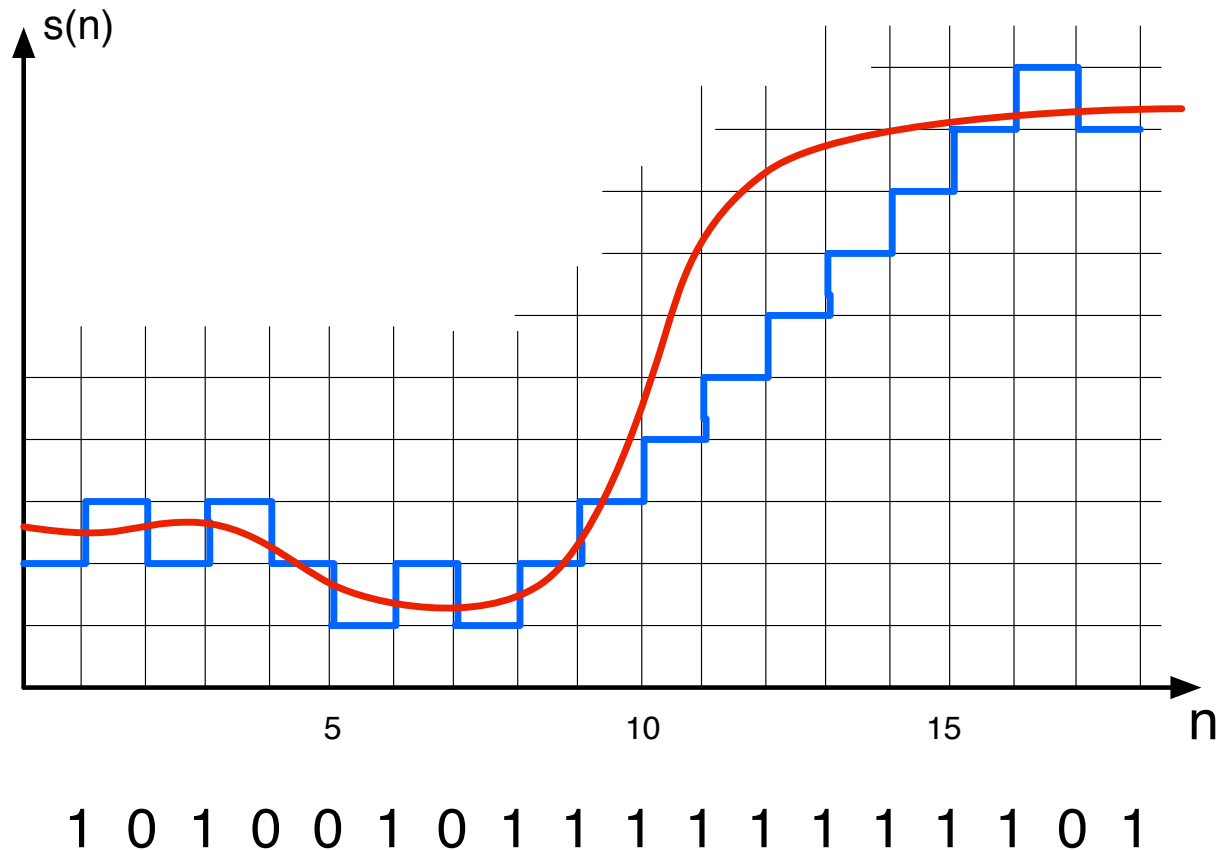

Examples

Telephony

$$F_{\max} = 4 \text{ kHz}$$

$$F_s = 8 \text{ kHz (samples per sec)}$$

$$8 \text{ bit/sample} \Rightarrow 64 \text{ kb/s}$$

CD

$$F_{\max} = 20 \text{ kHz}$$

$$F_s = 44.1 \text{ kHz (samples per sec)}$$

$$16 \text{ bit/sample} \Rightarrow 705.6 \text{ kb/s}$$

2 channels (stereo)

$$\Rightarrow 1.4 \text{ Mb/s}$$

Principles of circuits

- Sample and hold (sampling)
- ADC (quantisation)
- DAC (reconstruction)

Sample and hold

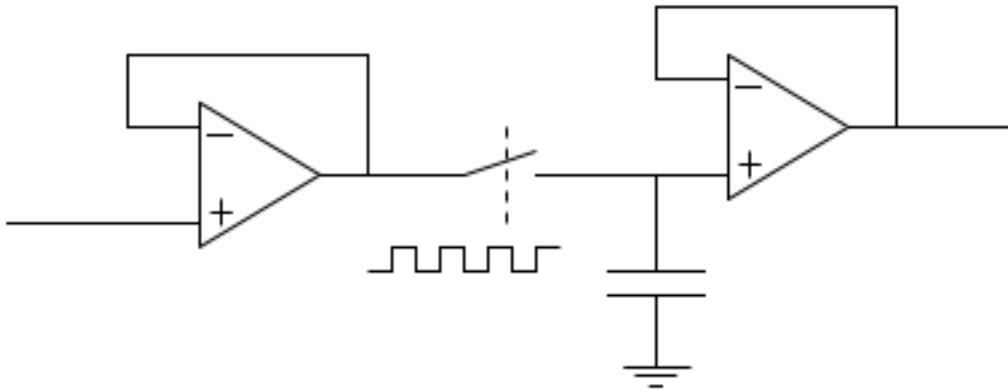

ADC

Analog to Digital Converter

- Sample and hold circuit freeze the analog value during conversion
- ADC methods
 - Direct conversion (flash ADC)
 - Integrating
 - Wilkinson
 - Sigma-delta
 - Etc (see e.g. https://en.wikipedia.org/wiki/Analog-to-digital_converter)

ADC Direct conversion example (3 bit)

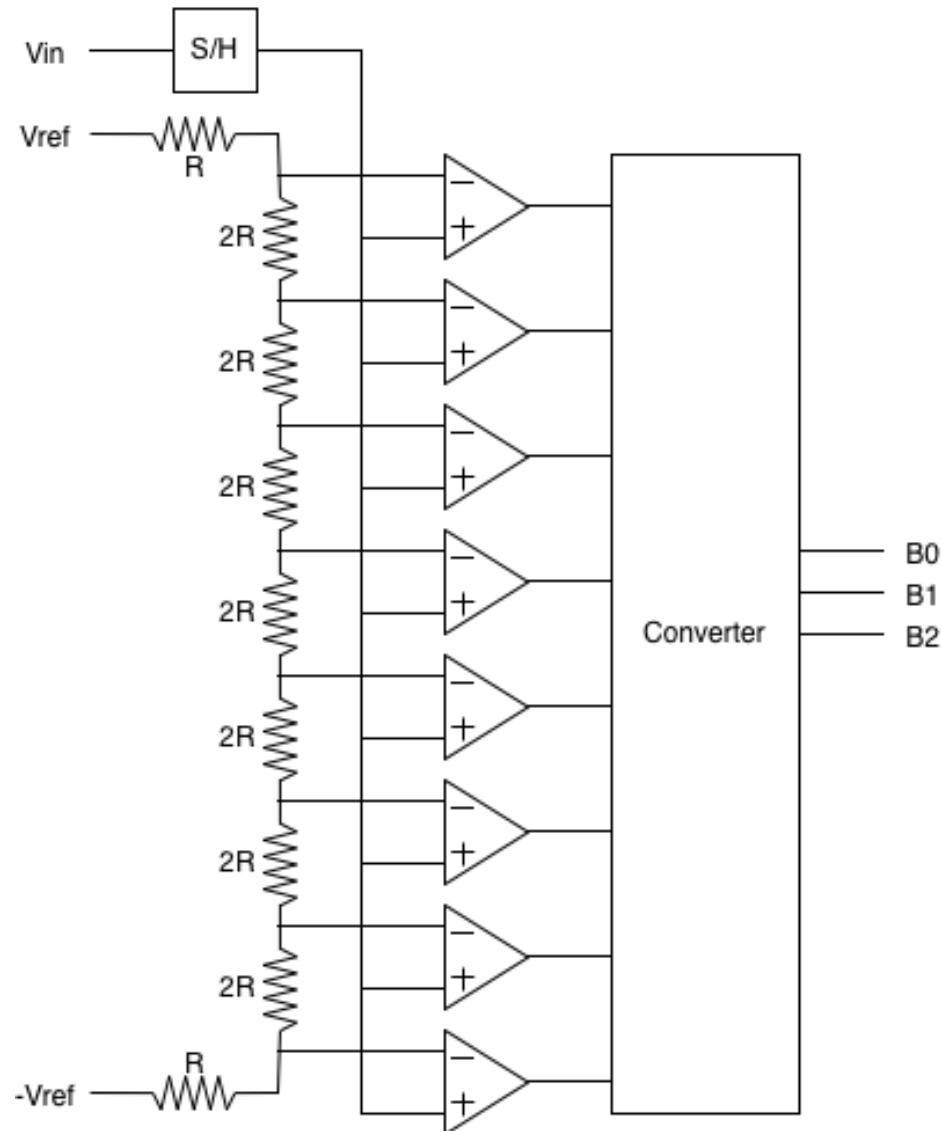

DAC

Digital to Analog Converter

- Pulse width modulator
- R-2R ladder
- Interpolating
- Binary weighting

See more on https://en.wikipedia.org/wiki/Digital-to-analog_converter

DAC Example

Weighted resistor

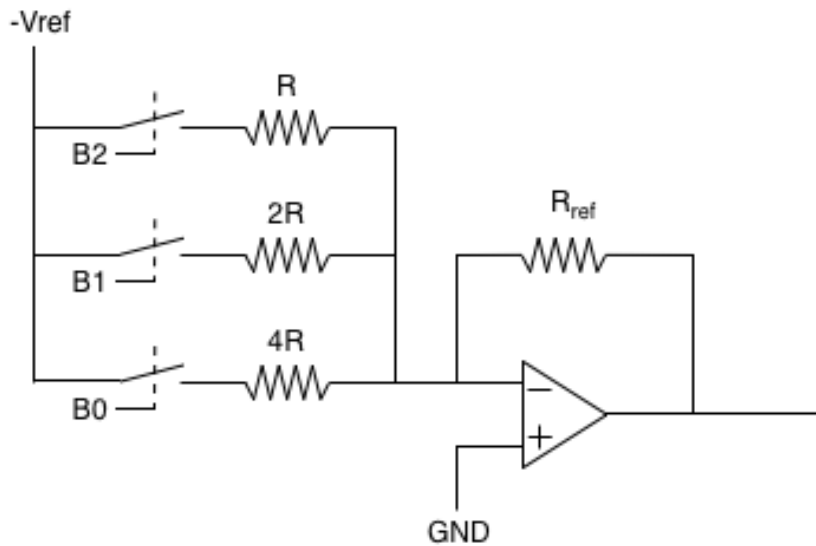

R-2R ladder

