

ETSF15: Lecture 5

- Routing
- Network protocols
 - IPv4/IPv6
 - ARP/NDP

Jens A Andersson



Link topologies

Bus



Ring

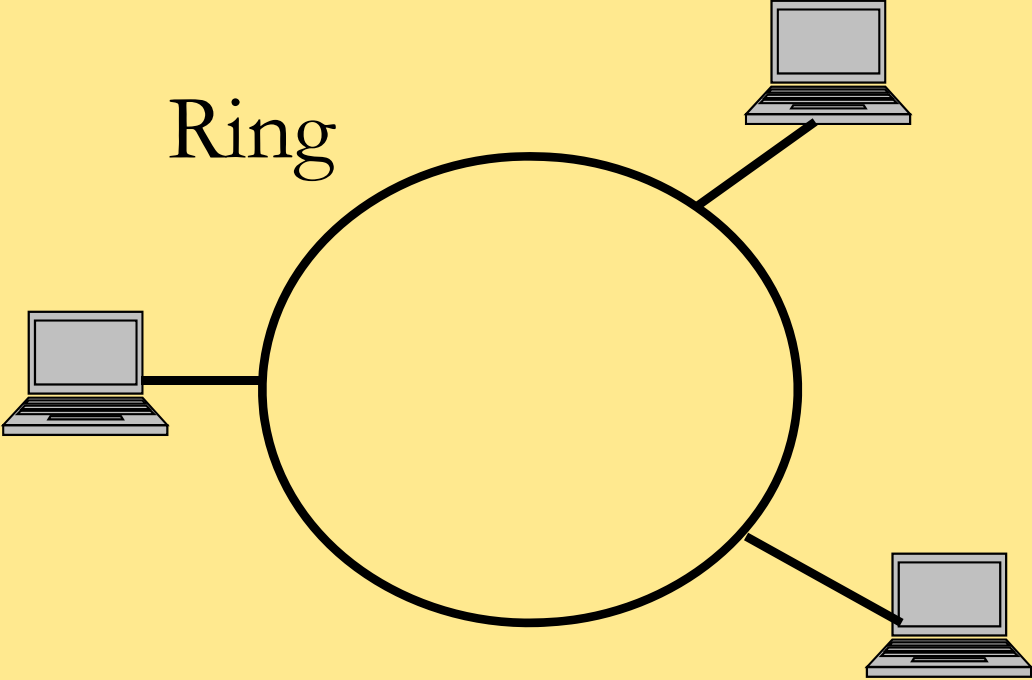

Star

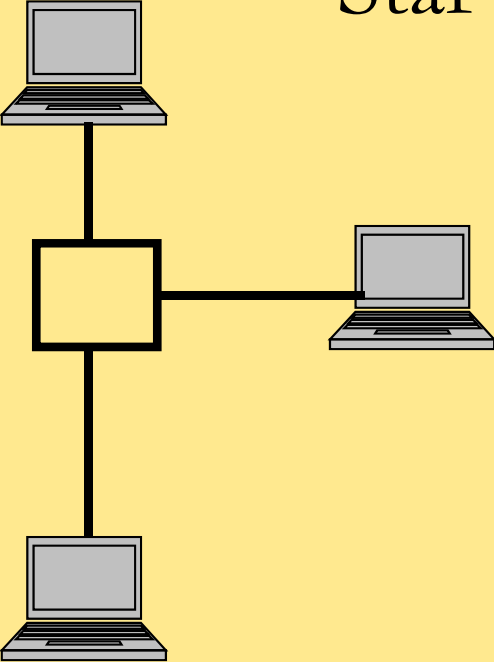

Generic multiplexing

Allocate channels in the available transmission medium

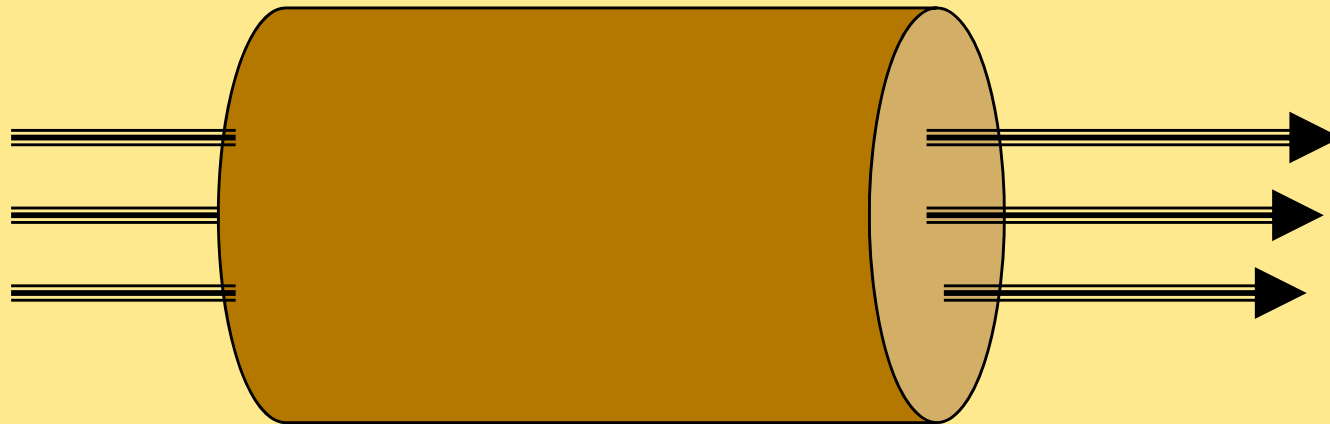

Synchronous time division multiplex

- Forwards one frame per channel in round robin
- If channel has nothing to send, corresponding time slot is empty.

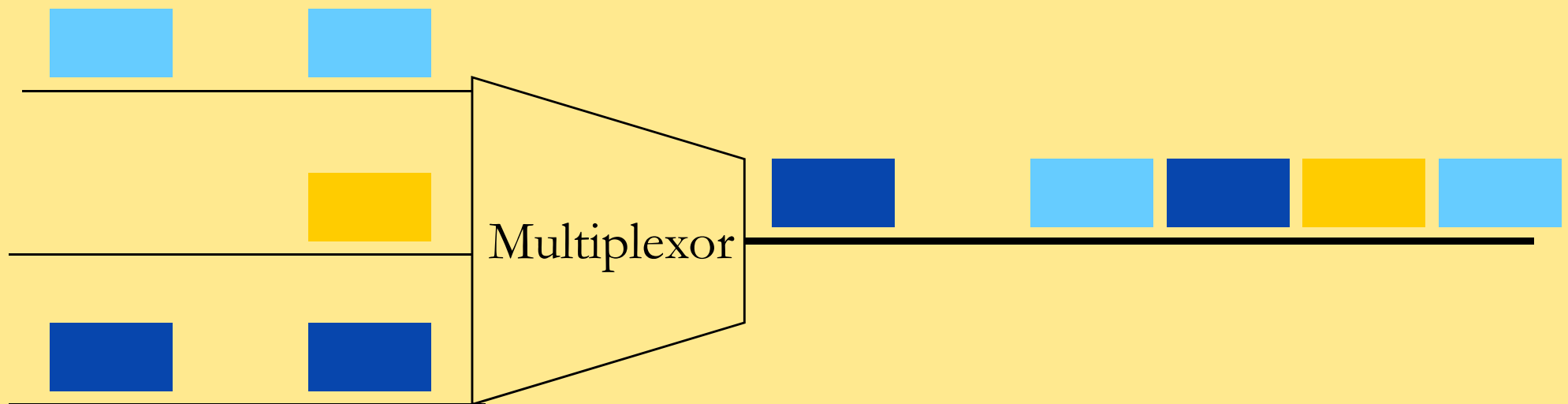

Statistical time division multiplexing

- Frames are transmitted as they arrive.
- Need buffering if outgoing link is occupied.
- Need 'address' for channel identification

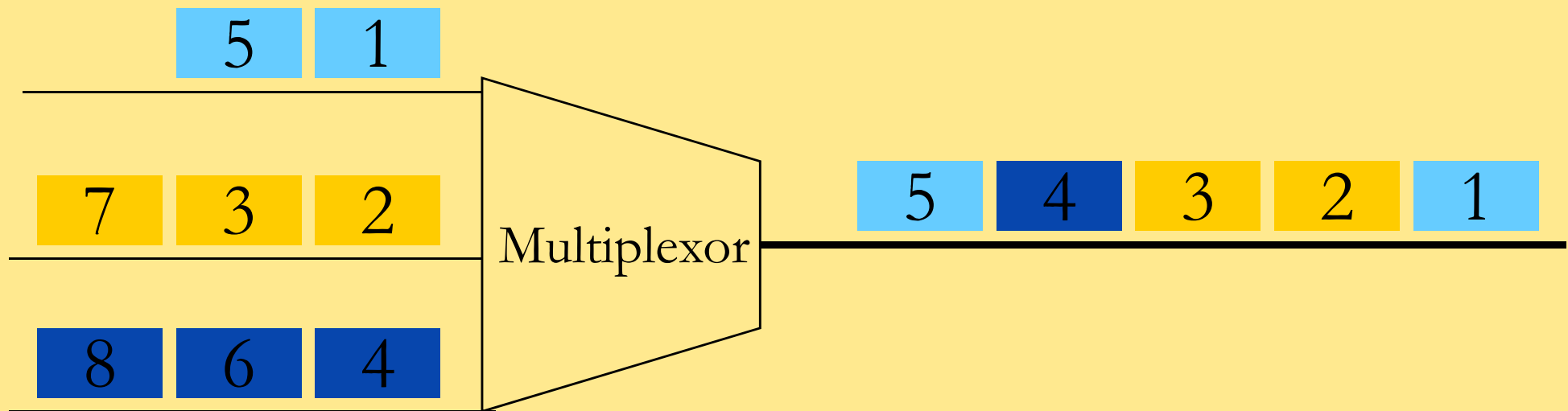

Access methods

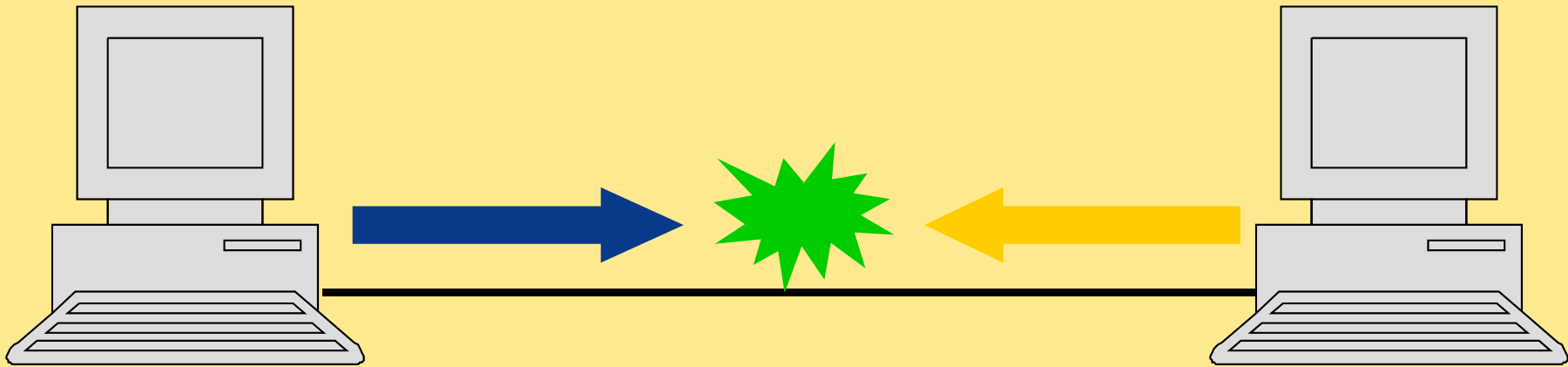

Multiple access requires ordered access!

ALOHA

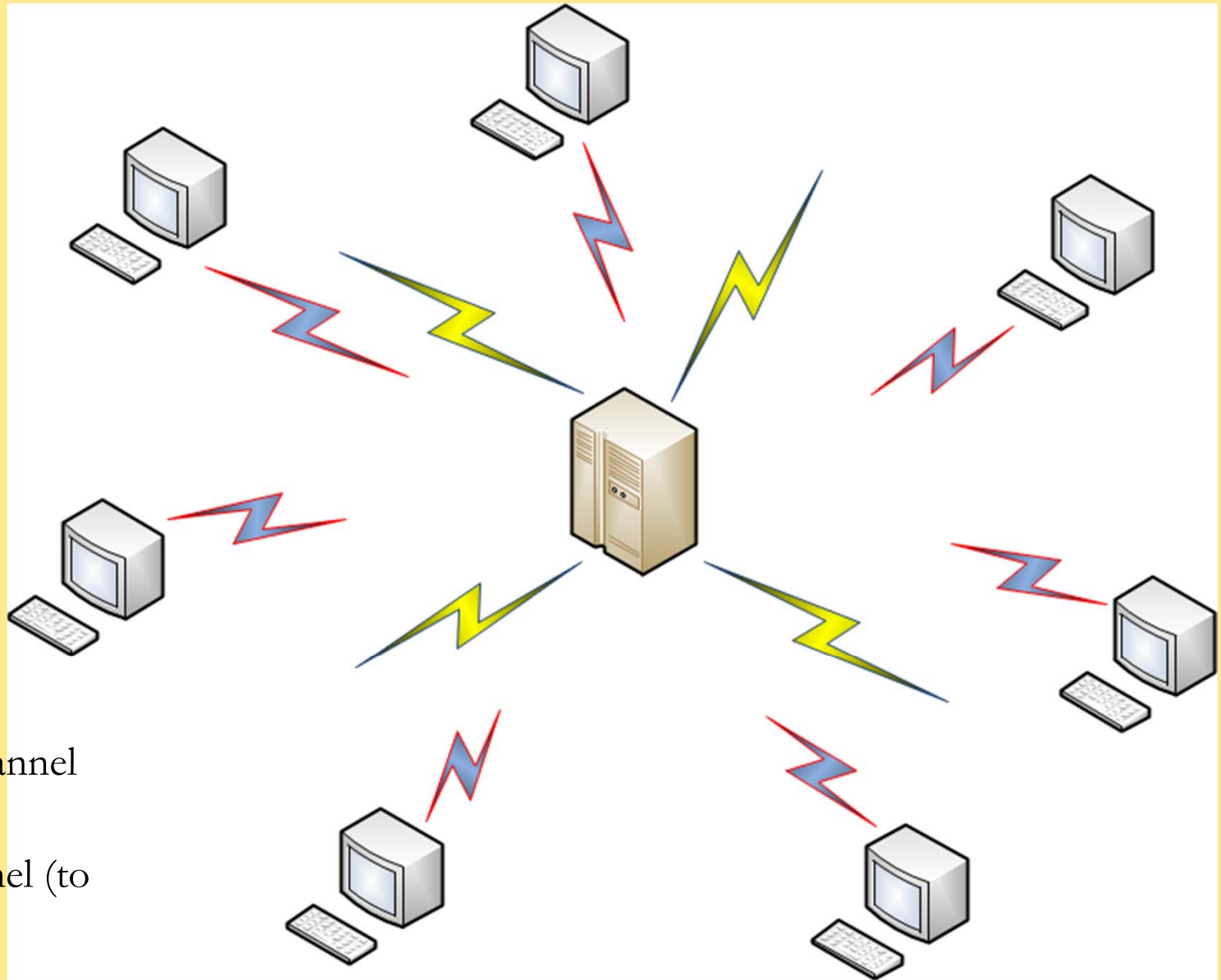

Yellow=Broadcast channel
(from central node)

Blue=Common channel (to
central node)

University of Hawaii (1971)

Carrier Sense Multiple Access (CSMA)

CS: Listen before
transmit

- ◆ If busy, wait and try
again

CSMA/CD

- ◆ CD: Collision Detection
- ◆ Listen for collision while
transmitting
- ◆ Works only in wired
environment

CSMA/CA

- ◆ CA: Collision avoidance
- ◆ Request channel before
sending
- ◆ RTS/CTS (master/slave)

The need for addresses

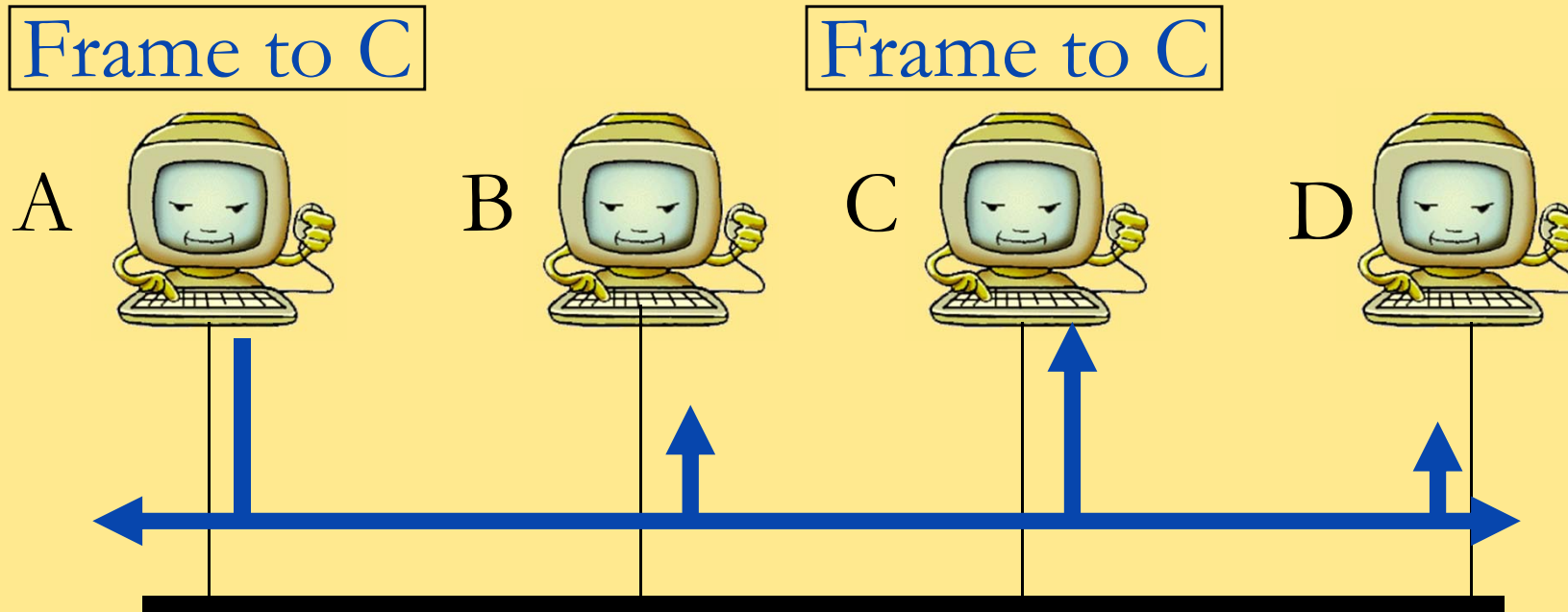

- ◆ All stations must have a unique address.
- ◆ All stations receives frame.
- ◆ Only addressed station handle the frame

Domains

- Collision domain
 - ◆ Every station are effected by the same collision
 - ◆ Number of (busy) stations in a domain affects throughput
- Broadcast domain
 - ◆ Every station receives the same broadcast message
 - ◆ Alas: there exists a broadcast address!
 - ◆ Number of stations/broadcasts in a domain affects throughput

Circuit switching

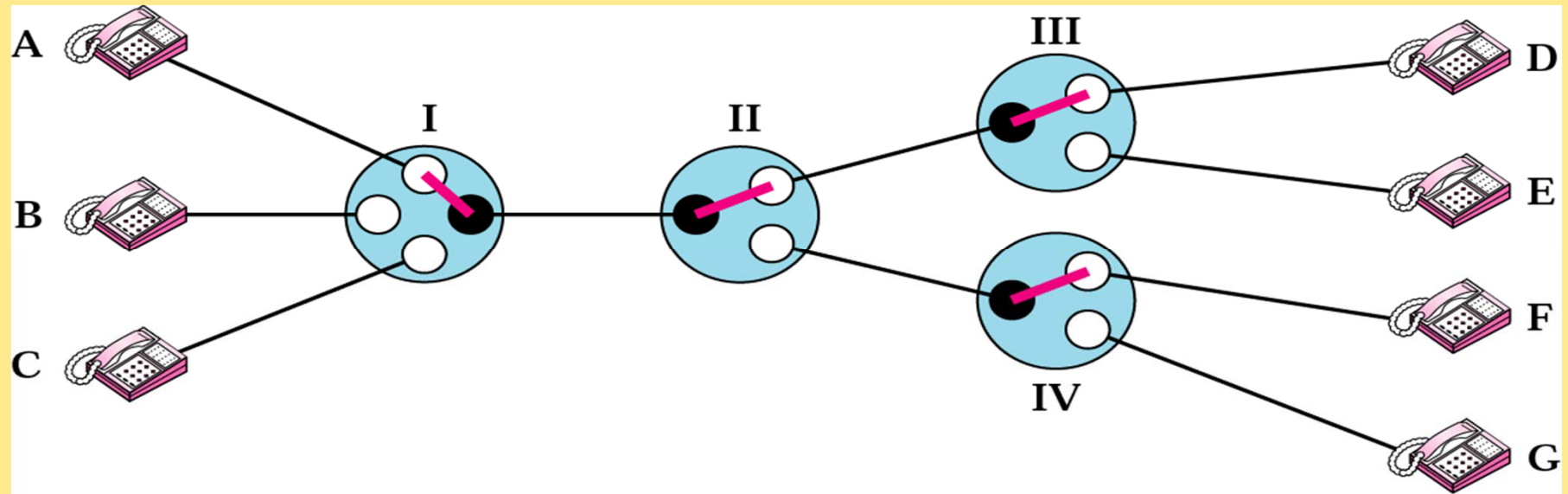

Packet Switching

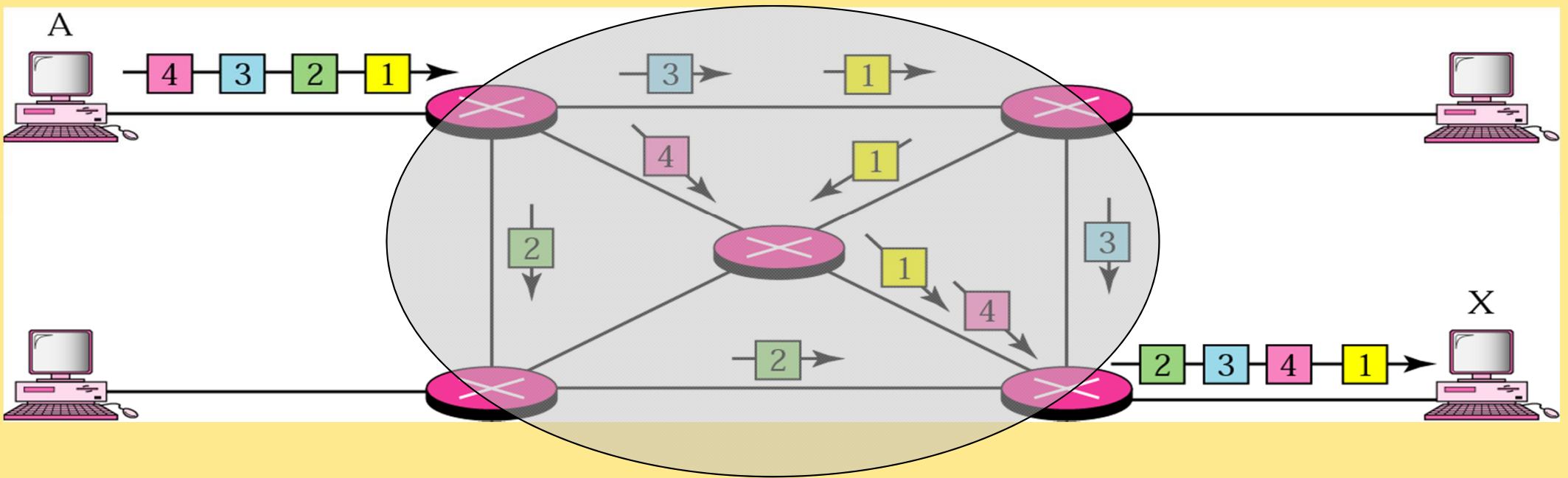

Ethernet, wired

- Ethernet developed by Xerox, Intel and DEC 1976.
- IEEE 802.3 is based on Ethernet.
 - Ethernet version II is included in IEEE802.3
 - Differences in the frame format but can co-exist on same link as 802.3.

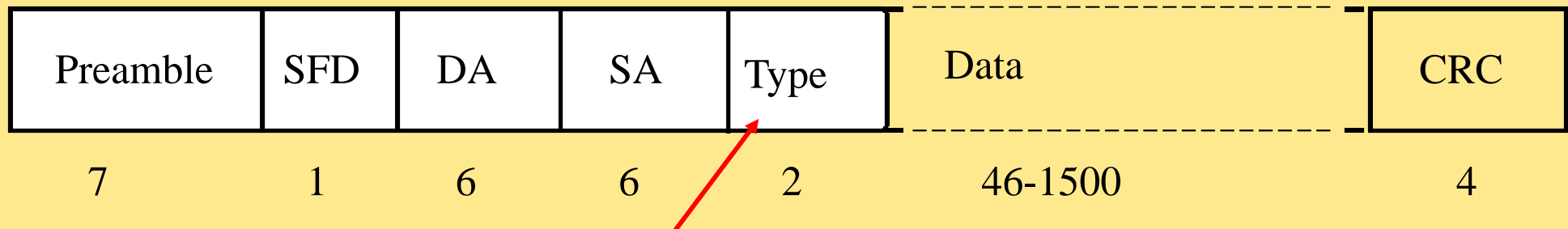

SFD=Start frame delimiter DA=Destination address SA=Source address

Protocol structure so far

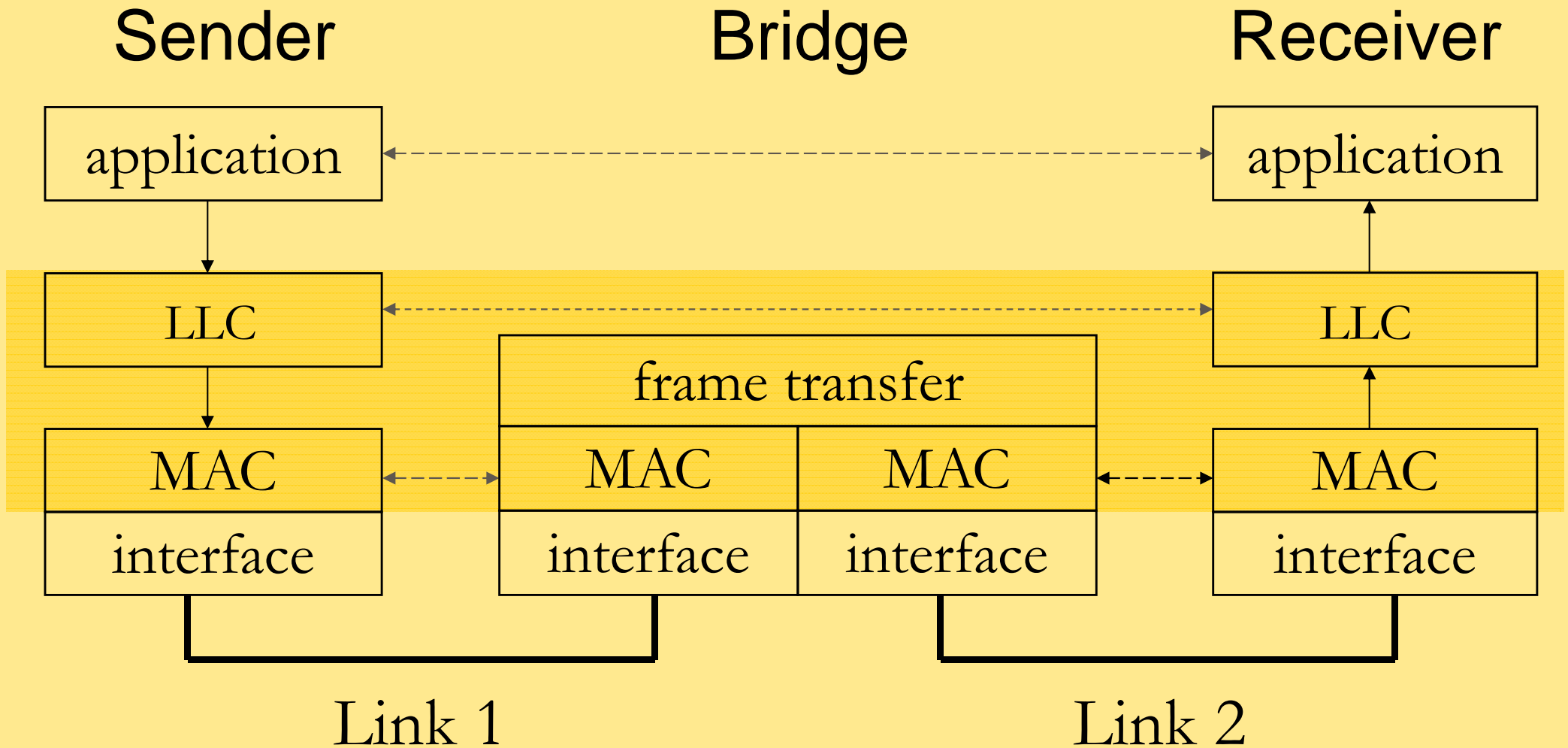

A bridge recognises frames!

Extended Networks

- ⌘ All layer 2 networks have limitations in reach.
- ⌘ There is a demand for connecting networks.

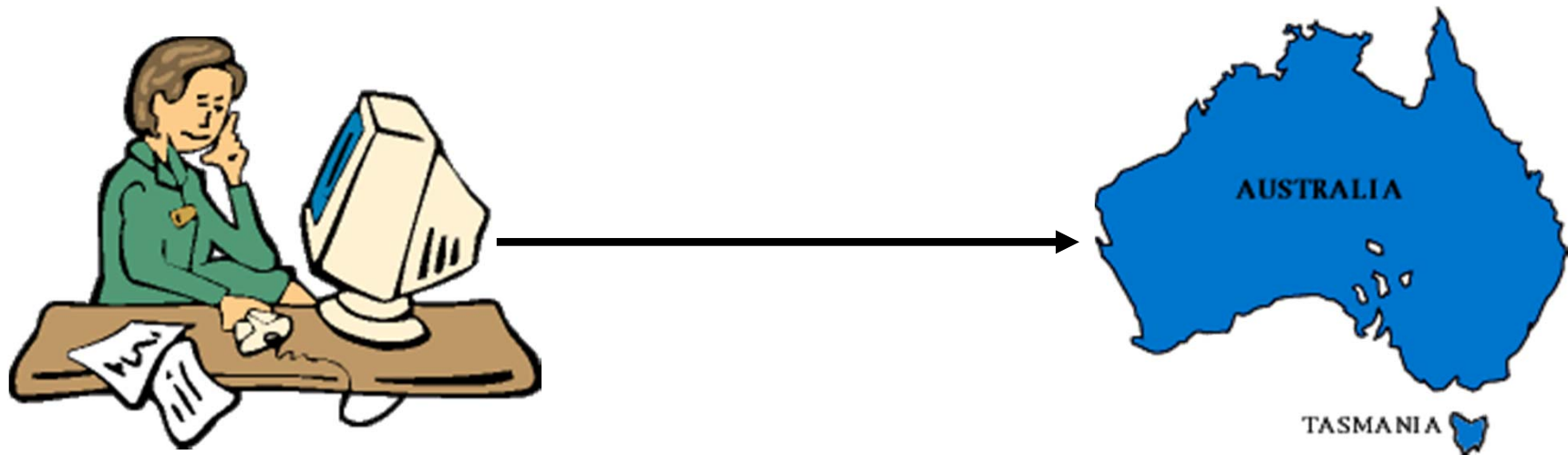

Layer 2 networks for long reach

⌘ SONET/SDH

- ◆ encapsulates several telephone calls (64kbps) in a hierarchy of flows
- ◆ flows can be added or dropped

⌘ ATM

- ◆ for telephony and data
- ◆ cells, small equal sized frames
- ◆ "packet switching" over virtual circuits (label switching)

⌘ Ethernet based networks for long distances

⌘ WDM – Wavelength Division Multiplexing

Switches selects routes?

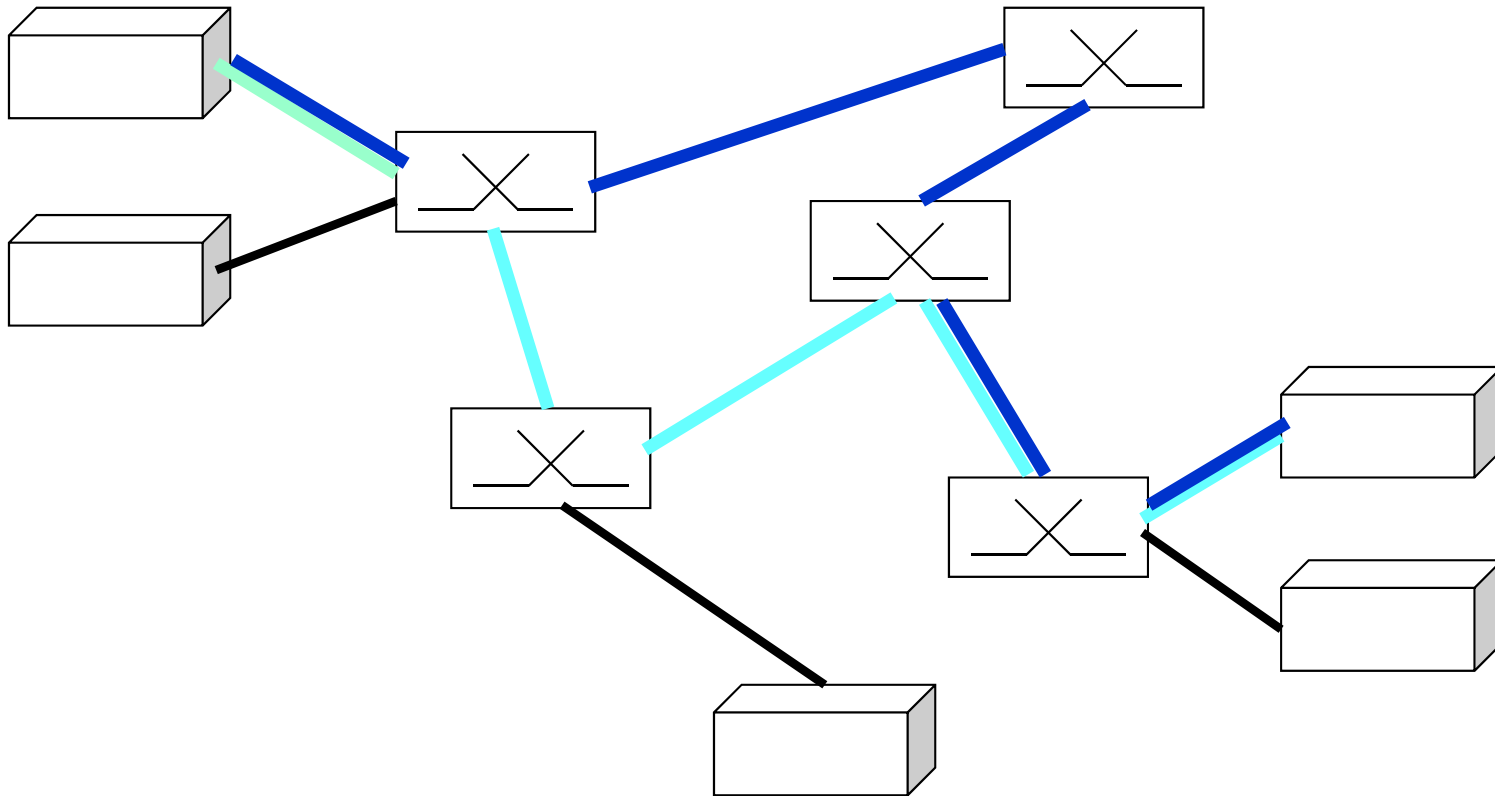

- In networks there might (preferable) exist multiple paths.
- Switches must keep track of all stations!

The objective of a switch?

- Connects networks with *same L2 protocol*
- Selects next network for incoming frames depending on destination address.

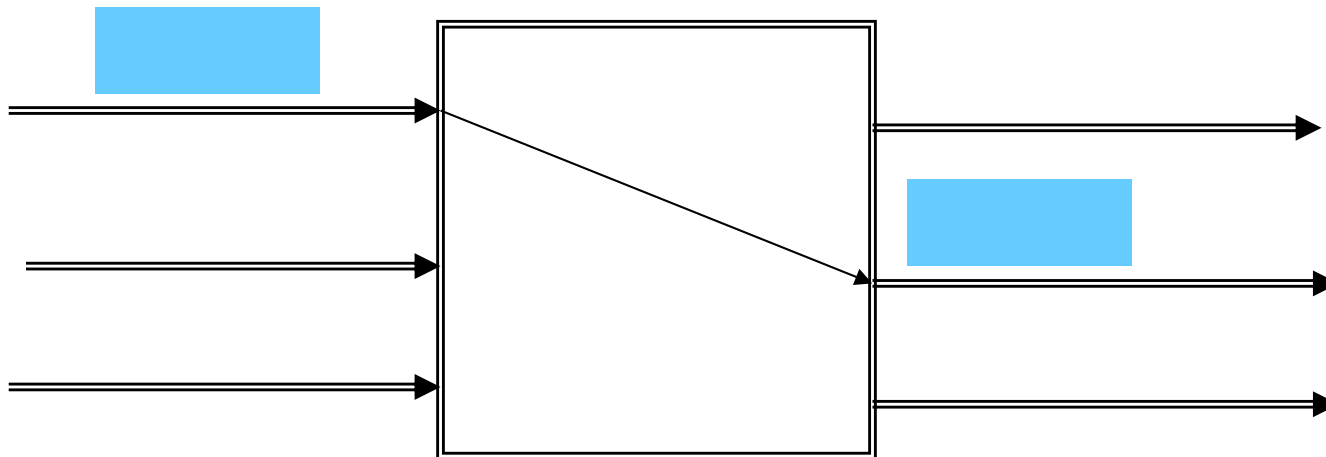

Routing

- Routing = selection of best path to destination
 - ◆ Router generic name for a best path selector on layer 3
 - ◆ Some layer 2 protocols include some form of routing
- Adapt best path to dynamics in the network
- Based on Graph theory
 - ◆ E.g. Dijkstra Shortest Path First
- Switching/Forwarding = select output interface and next hop based on best path

Routing (cont ...)

Principles

- Centralised
 - ◆ Remote switching/forwarding nodes send network information to central node that finds best paths and pushes those to switching/forwarding nodes
- Distributed
 - ◆ All nodes share network information and find best paths

Flooding

- Incoming frames are copied out on all other ports.
- To break loops: All frames must have a hop counter.

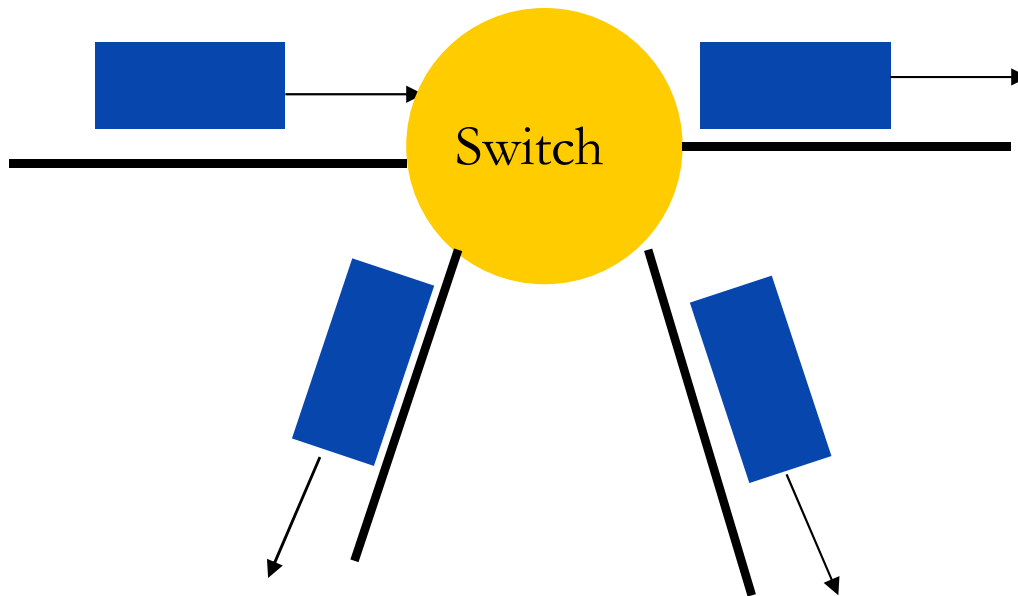

Network graphs

- A graph has nodes and edges
 - ◆ (sv noder och bågar)

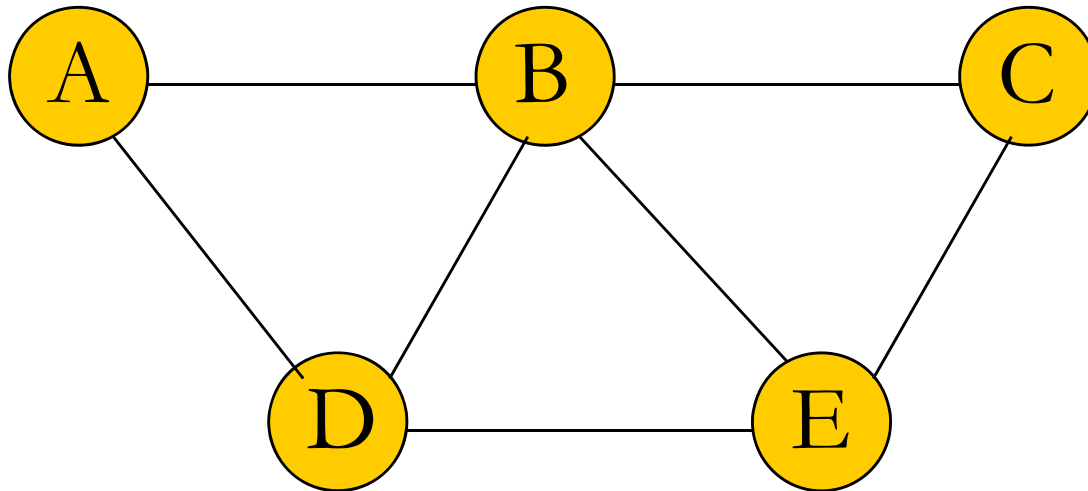

Nätgraf forts.

- Each edge is assigned a cost
- In network cost to use a link

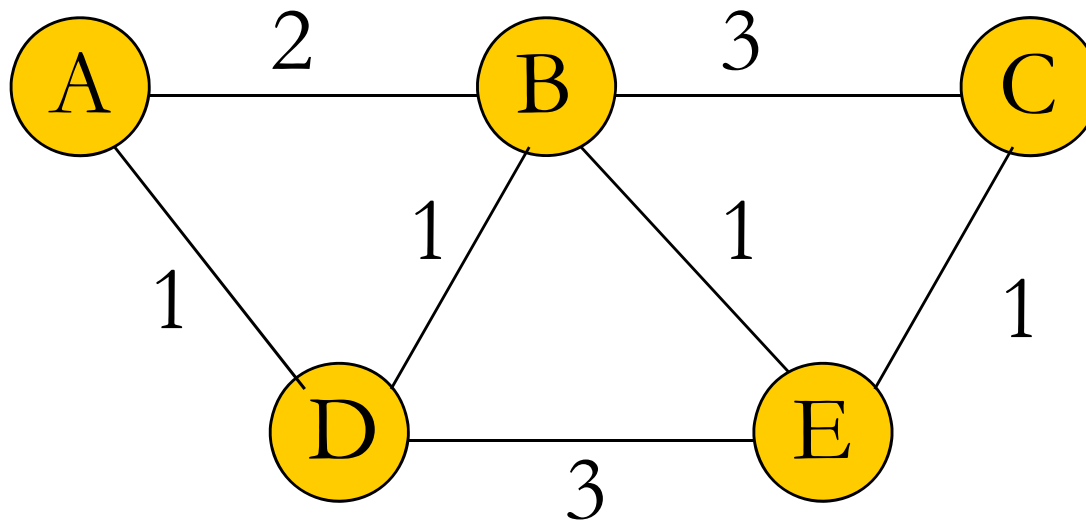

Link cost metrics

⌘ Capacity/Bit rate

⌘ Load

⌘ Type of network

⌘ Fixed

⌘ Mobile

⌘ Wifi

⌘ Latency

⌘ Etc ...

Least-hop path

- Least-hop path assumes link/edge cost is equal for all links/edges
- Path with least hop is preferred

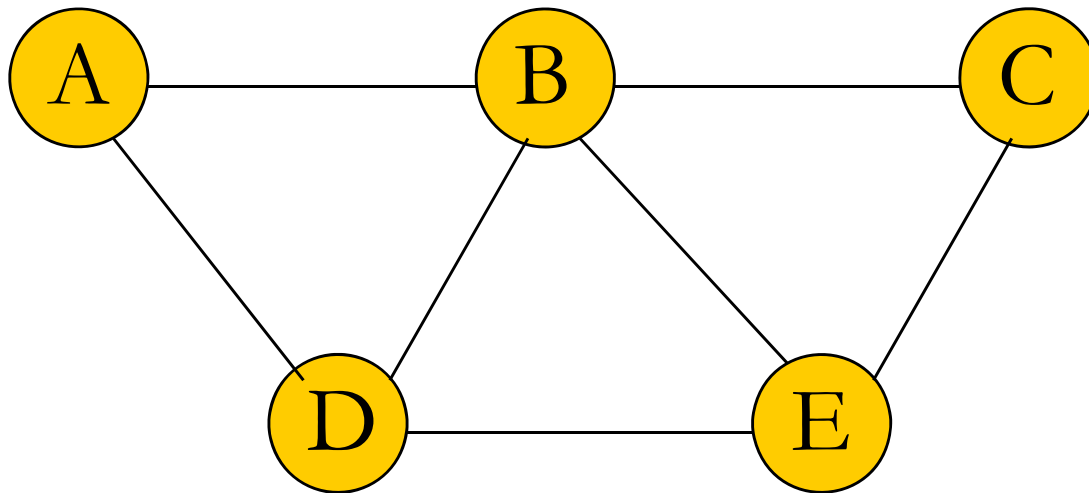

Least-cost path

- Adapt to different link/edge cost
- Path with least cumulative cost is preferred

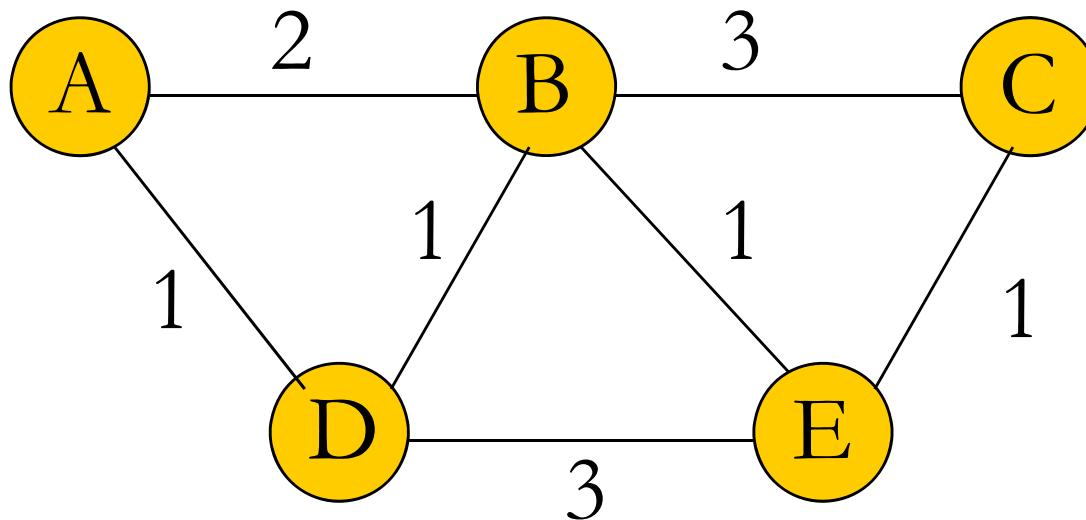

Problem!

If LANs don't have same L2 protocol?

- ◆ Different propagation media
- ◆ Different signaling
- ◆ Different frame structure
- ◆ Different MAC layer address formats

Solution: Network Layer Protocol

- Rides on top of any layer 2 network
 - Encapsulation
- Global address structure
 - Network ID requirement
 - Flat structure impossible; requires all addresses known to all switches
 - Host ID is address to individual host on a network
- Global frame format

Network Protocol

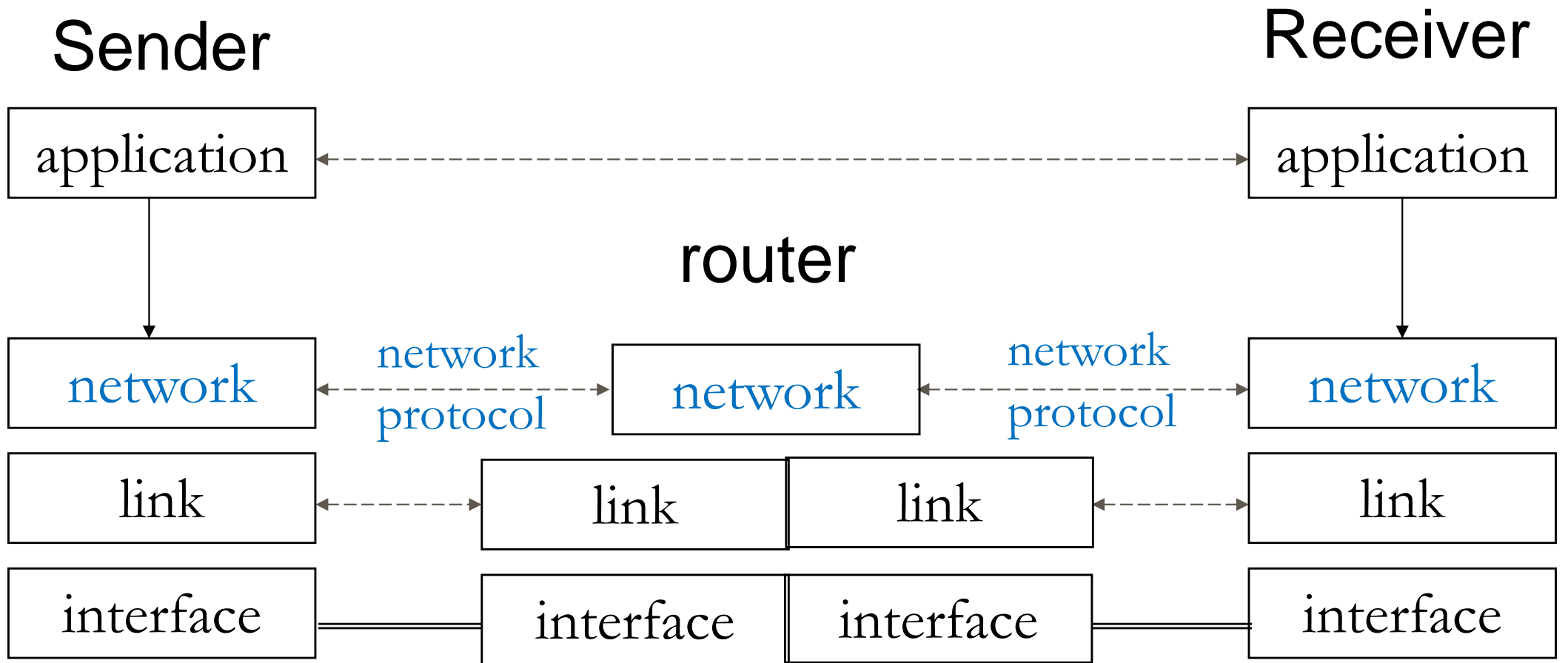

One Network Protocol: IP

- IP = Internet Protocol
- IP used on what is called Internet.
- IP defines IP addresses.
- Data transferred in IP packets/datagrams.
- Connection Free datatransfer.
- No error detection or control.
- This is called "best-effort".

Connection Oriented data transfer

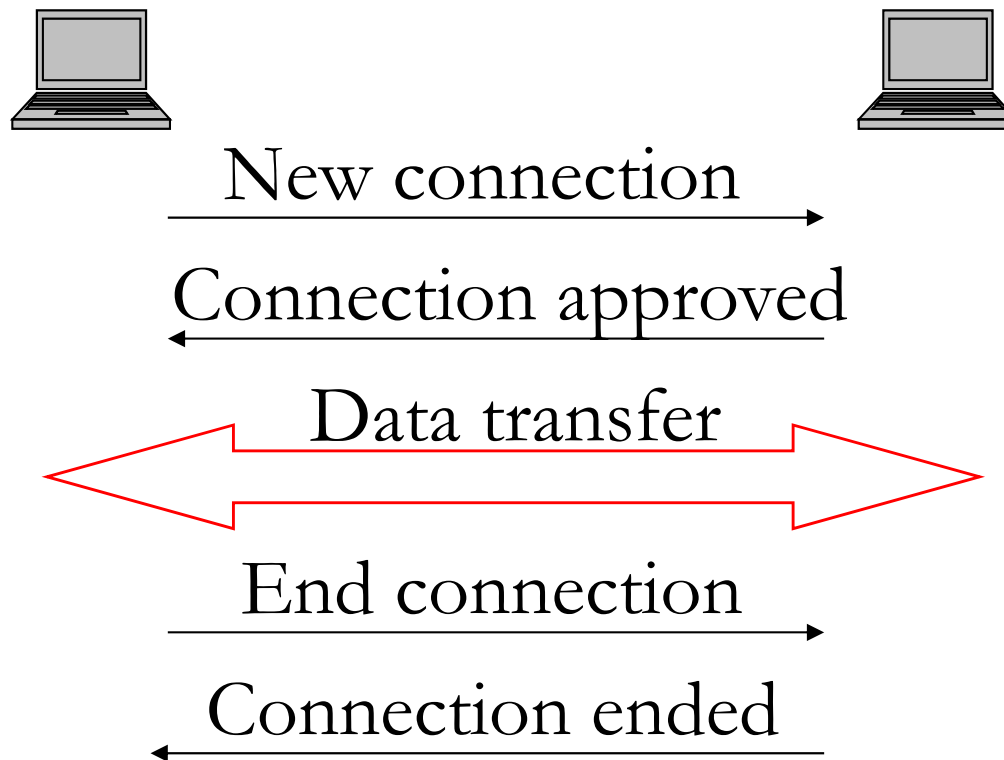

Connection Free data transfer

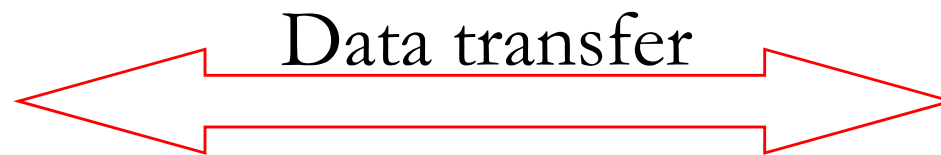

Internet Protocol

- Two versions in parallel: version 4 (IPv4) och version 6 (IPv6).
 - Incompatible
 - Translation needed
- IPv4 developed during 1970s.
 - All IPv4 addresses are allocated!
- IPv6 supports
 - More addresses
 - Realtime media transfer (built in)
 - Encryption and authentication (built in)

IPv4 datagram

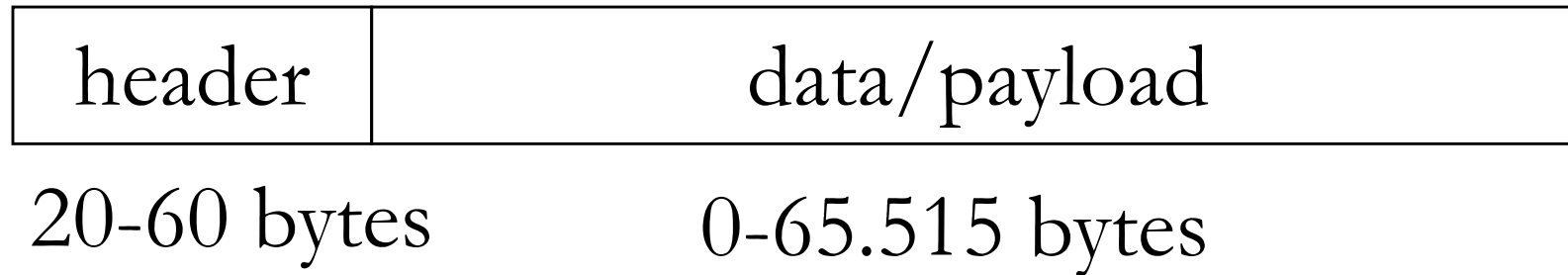

IPv4 header format

0	4	8	16	31
vers.	hl.	type	datagram length	
sequence number			frg.	fragment position
time to live		protocol	check sum	
source address				
destination address				
options			padding	

IPv4 address structure

- IPv4 addresses are 32 bits long.
 - ◆ $4.3 \cdot 10^9$ individual addresses
 - ◆ Only $3.8 \cdot 10^9$ can be used
- Printed as 4 decimal numbers; full stop as delimiter
 - ◆ Dot decimal notation
 - ◆ 4 bytes/octets

$$\begin{array}{c} 10000010 \ 11101011 \ 00010010 \ 10011110_2 \\ = \\ 130.235.18.158_{10} \end{array}$$

IPv4 address structure (2)

- Two parts:
 - ◆ Network identity (net id)
 - ◆ Host identity (host id)

One EIT IP address = 130.235.202.173

????

EIT network id = 130.235.200



IPv4 address structure (3)

Classful addressing

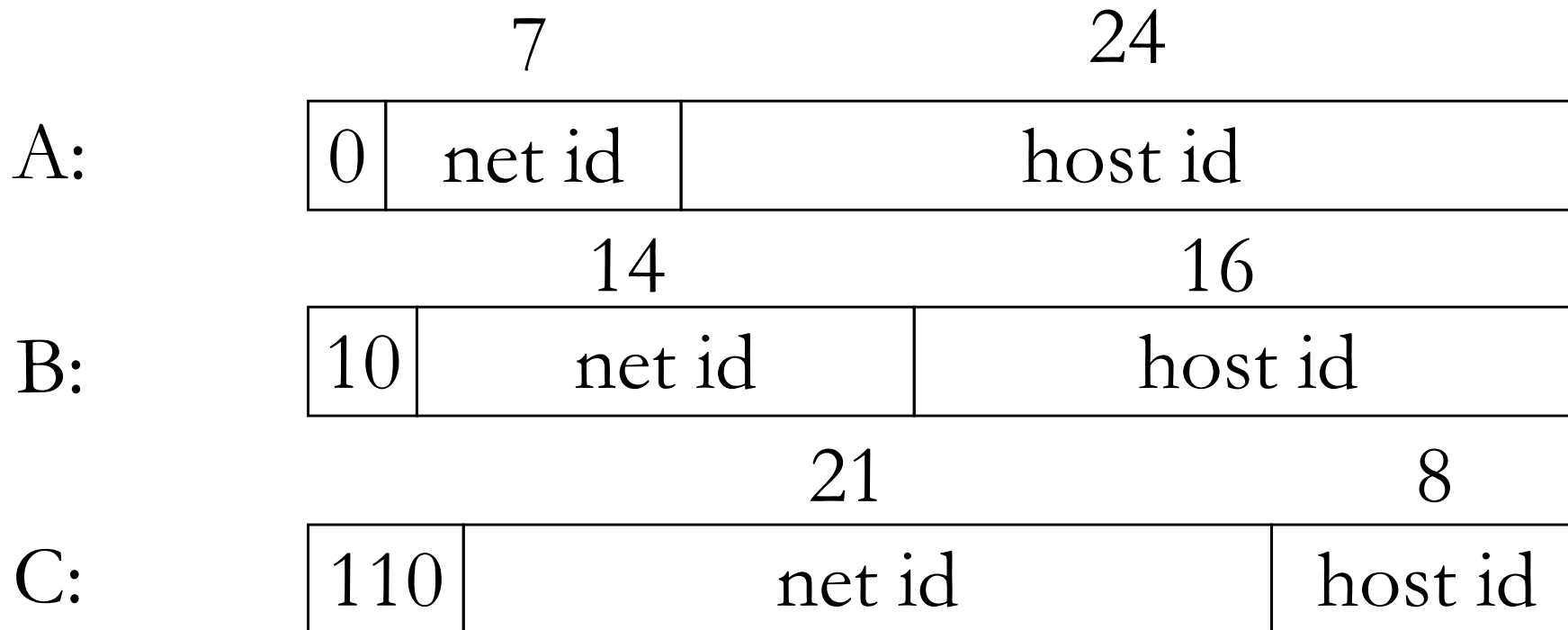

IPv4 address structure (4)

Subnetting

- Split network into subnets: Add a **subnet mask**
- 32 bit vector
 - ◆ Ones identify bits in net id
 - Always consecutive from the left
 - ◆ Zeros identify bits in host id
- 255.255.255.128
 - ◆ Splits one C net into two subnets
 - ◆ Splits one B net into 512 subnets

IPv4 address structure (3)

Classless addressing (CIDR)

- Skip classes
- Use only (sub)net mask

■ Address:	11011110 00010111 01000011 01000100
■ Mask:	11111111 11111111 11000000 00000000
■ Net id:	11011110 00010111 01000000 00000000
■ Host id:	00000000 00000000 00000011 01000100

IPv6 datagram

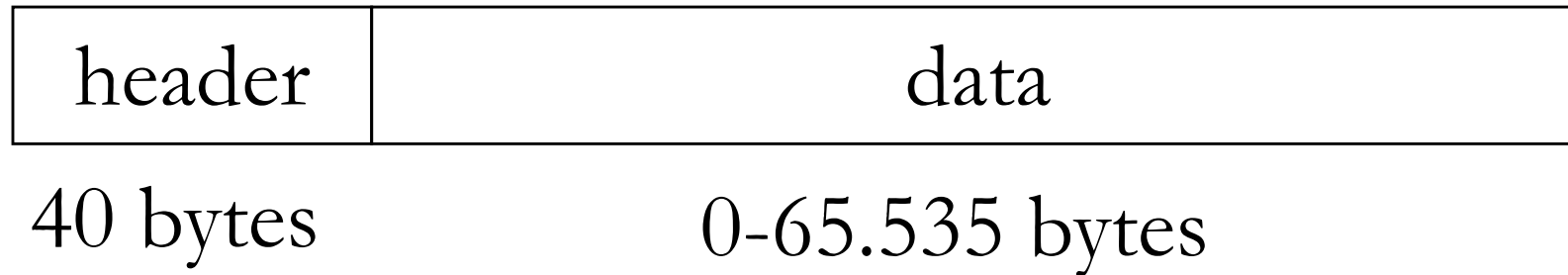

IPv6 header format

0 4 12 16 24 31

Vers.	Traffic class	Flow label		
Payload length		Next header	Hop limit	
Source address (16 bytes)				
Destination address (16 bytes)				

IPv6 address structure

- IPv6 addresses are 128 bits long
 - ◆ $3.4 \cdot 10^{38}$ individual addresses

010A : 1234 : E4F5 : 1003 : 4567 : BC98 : 0000 : 2341₁₆

IPv6 address structure (2)

- Address space divided into blocks
- Each block identified by its *block prefix*
 - 001 = *global unicast* ; host to host)
 - 1111 110 = *unique local unicast* ; corresponds to IPv4 private addresses, rfc 1918
 - 1111 1110 11 = *link local* ; used in combination with MAC address for auto configuration

IPv6 address structure (3)

- Printed as eight hexadecimal numbers; colon delimiter
 - ◆ Colon-hexadecimal notation
- Leading zeros in a group can be omitted
- Consecutive groups with zeros only
 - Can be printed as ::
 - Only allowed once per address

IPv6 address structure (4)

FDEC : 0102 : 0000 : 0000 : 0000 : EB82 : 0013 : 14A5

can be shortened to

FDEC : 102 :: EB82 : 13 : 14A5

IPv6 address structure (5)

- Net id or host id?
- Compare IPv4 (sub)net mask
- Printed as number of consecutive ones
- Exempel **prefix**: FDDEC::BBFF:0:FFFF/60
 - The first 60 bits gives the net id

Check Sum (Hash Sum)

- Split the bit vector into equal sized segments
- Calculate sum over all the segments
- Remove carry bits and add to the sum

- Before transmission
 - ◆ Calculate the sum's one complement
- Send segments and the one complemented sum

Check Sum (Hash Sum) (2)

Receiver side:

- ◆ Split the bit vector into equal sized segments
 - same segments size as the sending end
- ◆ Calculate sum over all the segments
 - Remove carry bits and add to the sum
- ◆ Calculate the sum's one complement
- ◆ If complement of sum = 0 then segments are received without error

From IP address to MAC-address

- Hosts have to know MAC addresses to be able to communicate on one LAN
- Find out the MAC/IP address mapping
 - IPv6 uses sub protocol of Neighbor Discovery Protocol (NDP)
 - IPv4 uses Address Resolution Protocol (ARP)

From IPv4 address to MAC address

ARP:

- Before transmitting an IP datagram sender must know of the corresponding MAC address on the same LAN
- ARP caches known IP/MAC address pair
- First look in ARP cache; if not found ask for it on the LAN

From IPv4 address to MAC address (2)

ARP request IP v.x.y.z (broadcast)

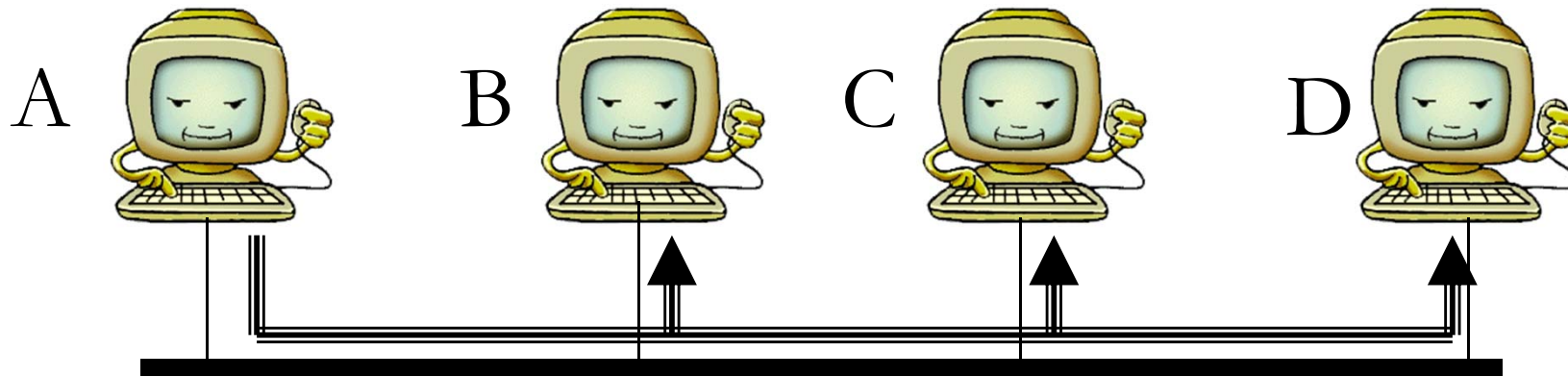

ARP reply MAC a:b:c:d:e:f

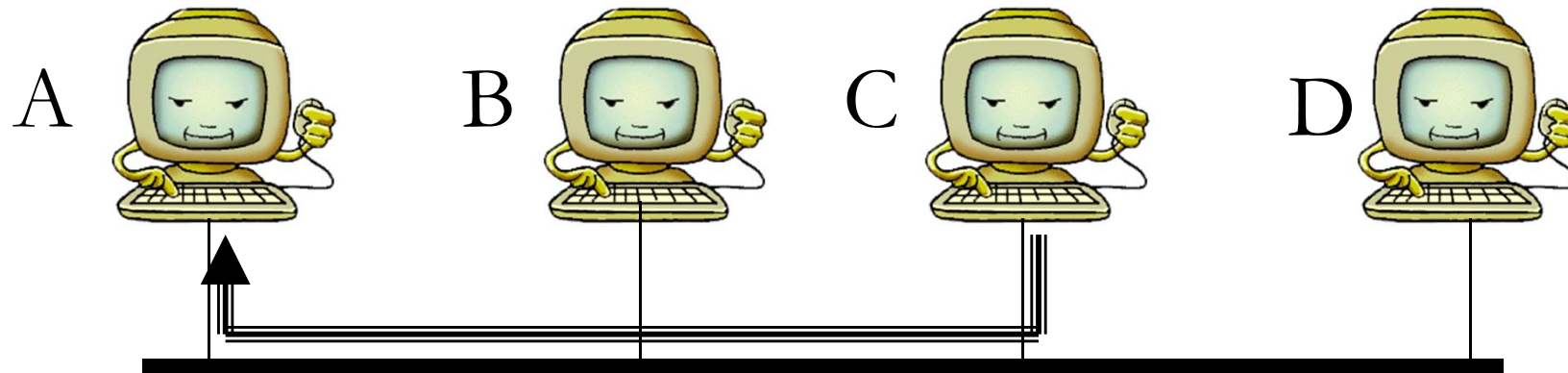

From IPv4 address to MAC address (3)

- If the IPv4 address is to another network the default gateway's MAC address has to be used

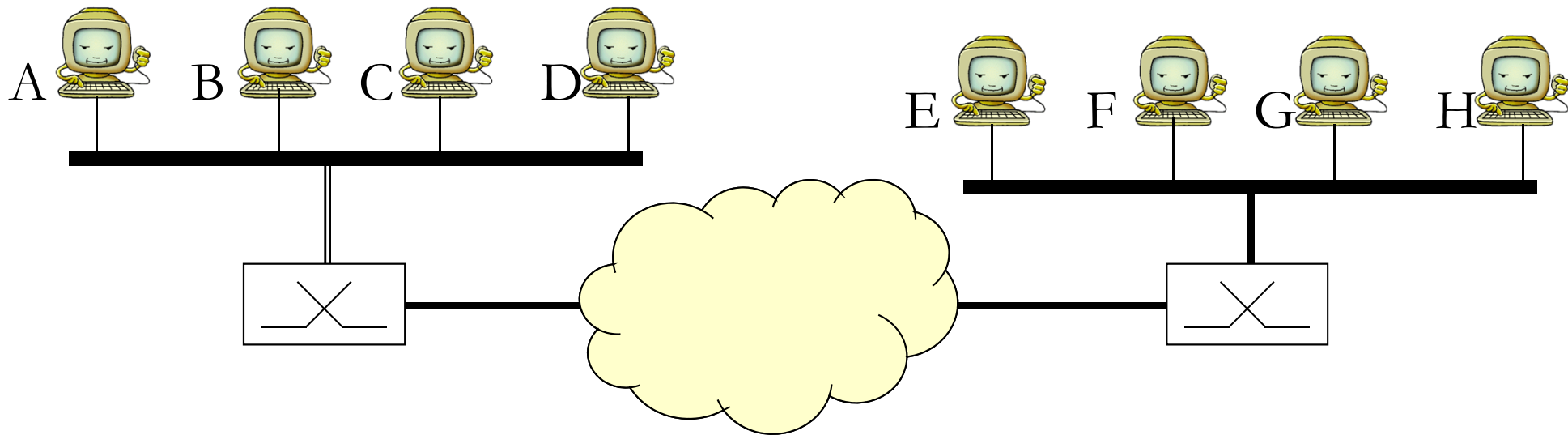

”Routing” in a host

- Sending host must know
 - Is destination on same network?
 - If not, which is the path to the outside world?
- Compare own net id with destinations net id:
 - If the same: ARP request for destination’s MAC address
 - If different: ARP request for default gateway’s MAC address

ARP (1)

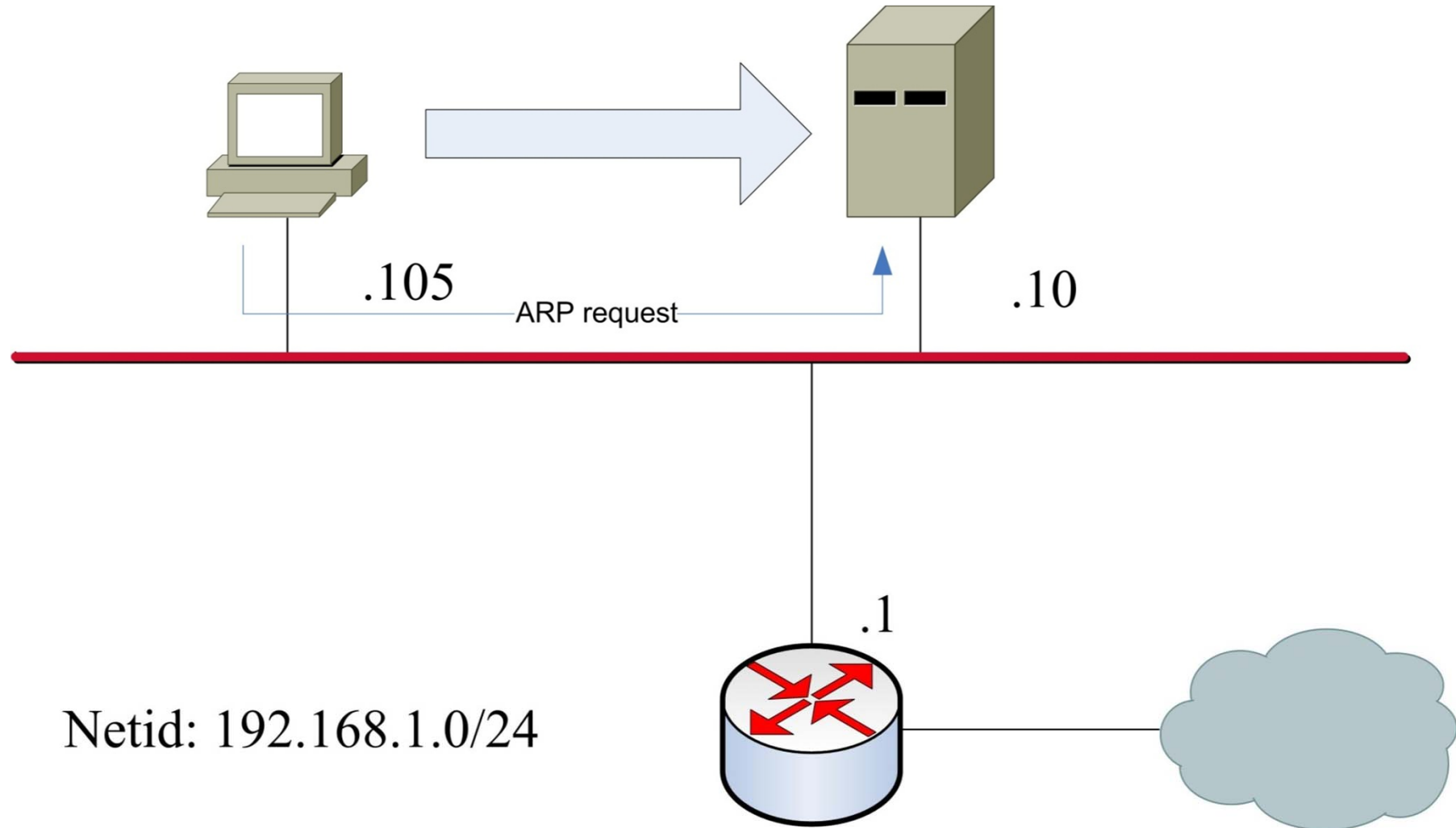

ARP (2)

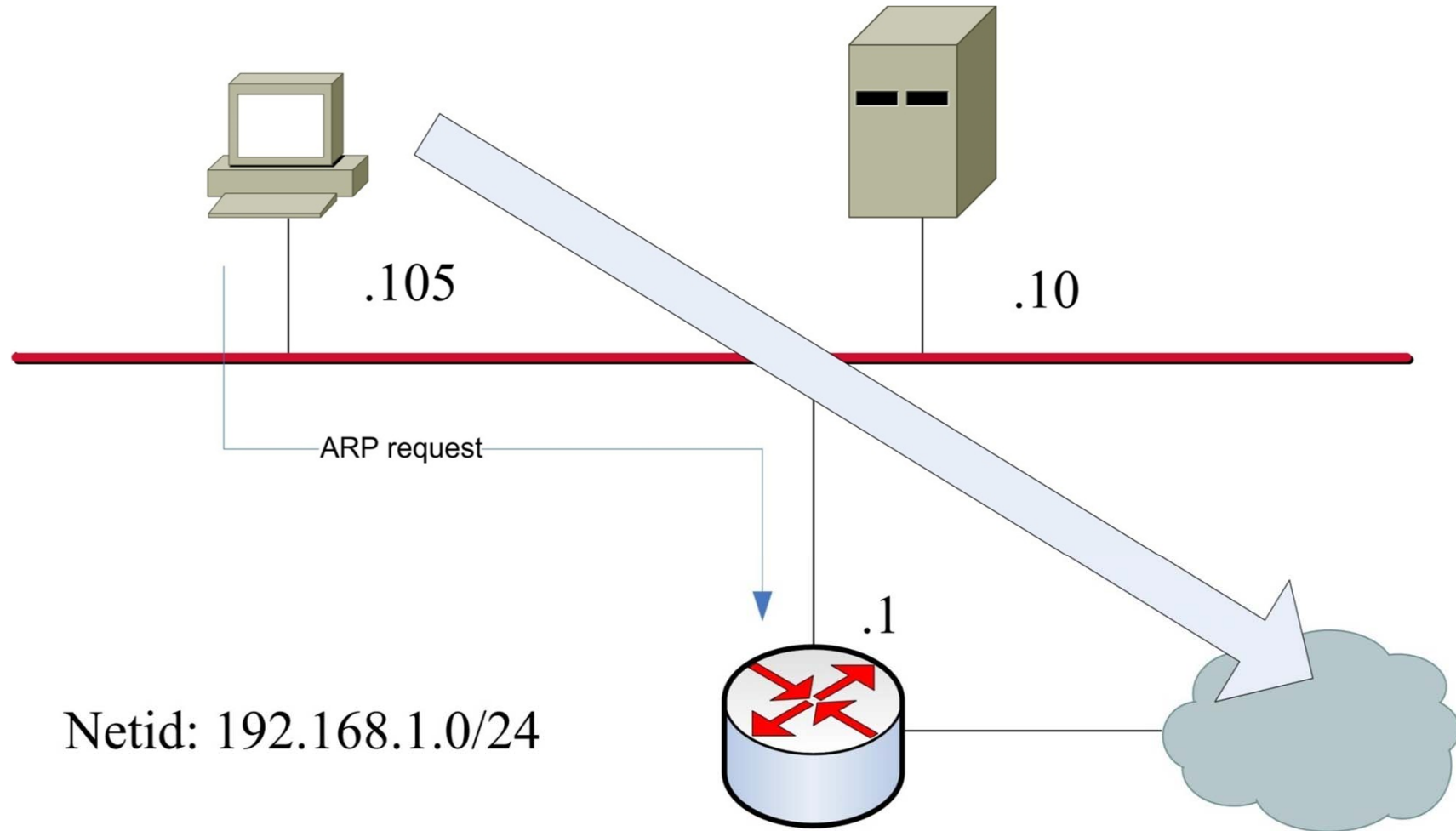

From IPv6 address to MAC address

- NDP instead of ARP
- NDP is part of **ICMPv6**
 - Internet Control Message Protocol
 - Supporting protocol for IPv6
- **Neighbor-Solicitation Message** corresponds to ARP request
- **Neighbor-Advertisement Message** corresponds to ARP reply

NDP (1)

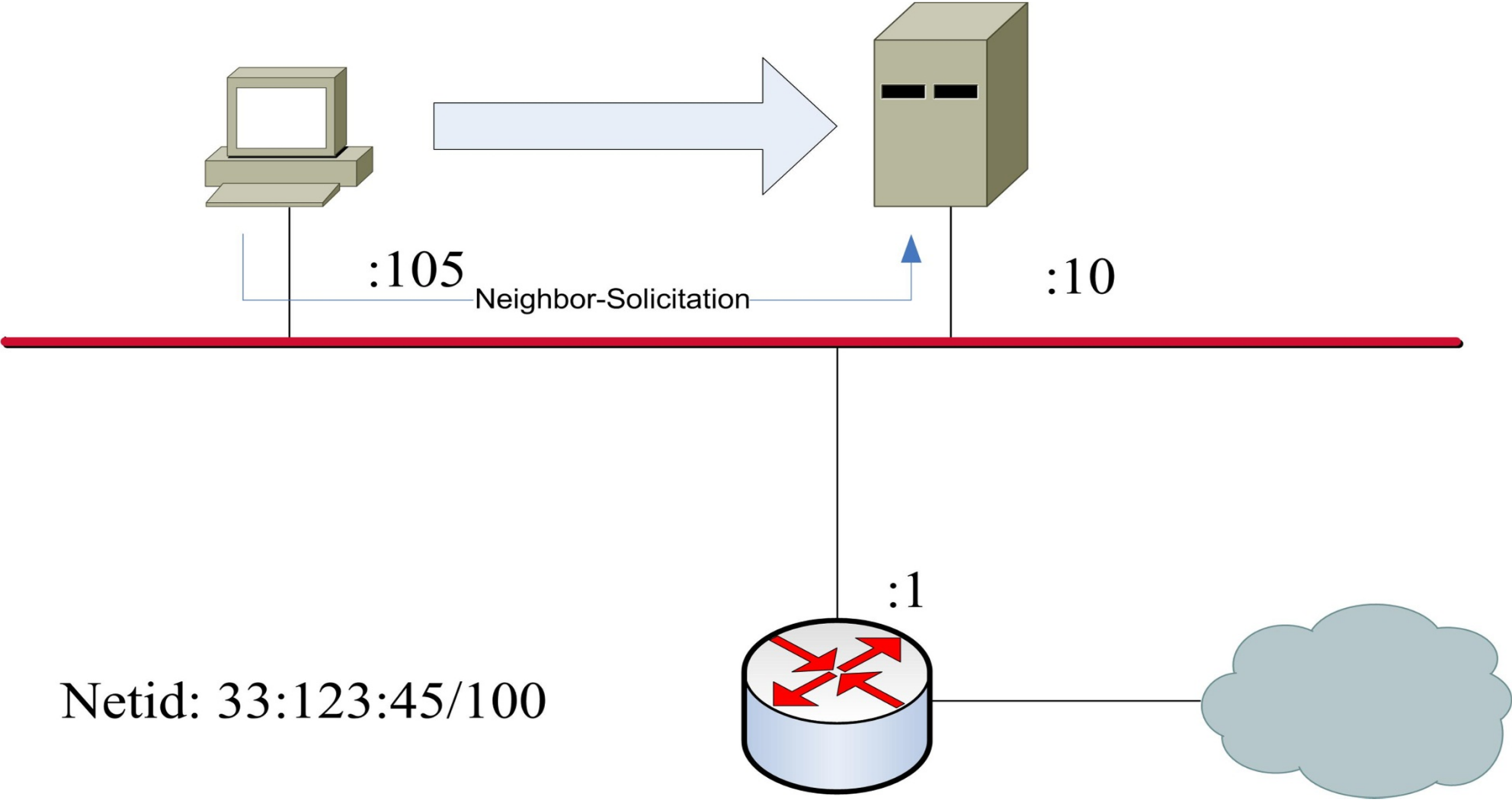

NDP (2)

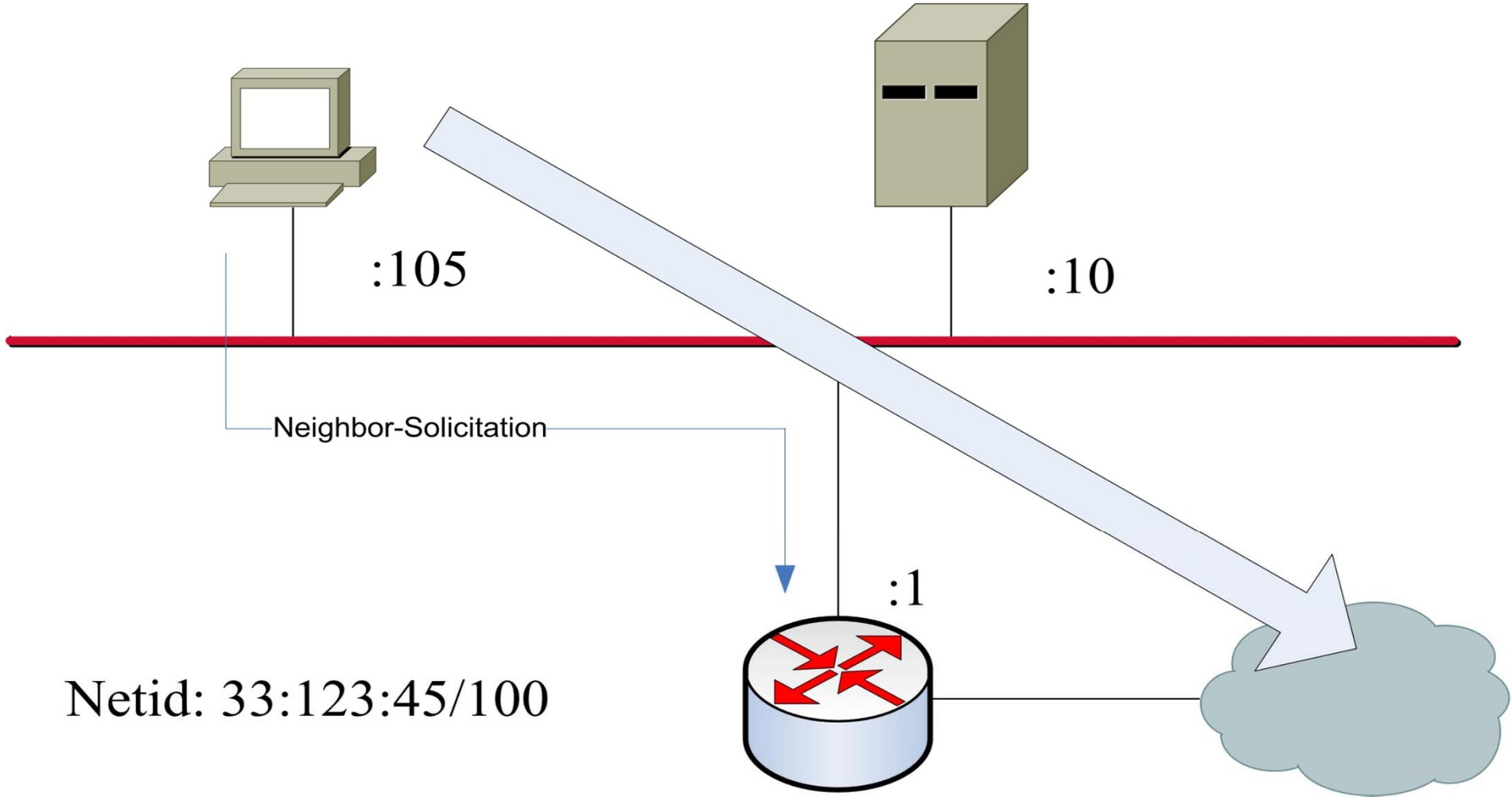

NDP (3)

Also Automatic Configuration

- Network Discovery
- Host "invents" own address
- Ask all stations on the LAN if there is a conflict
- Requests net id and default gateway's address