

# ETSF05/ETSF10 – Internet Protocols

SMTP

FTP

TFTP

DNS

SNMP

...

BOOTP

SCTP

TCP

UDP

## Routing on the Internet

IGMP

ICMP

IP

ARP

RARP

2015

Jens Andersson

Underlying LAN or WAN  
technology



# Circuit switched routing

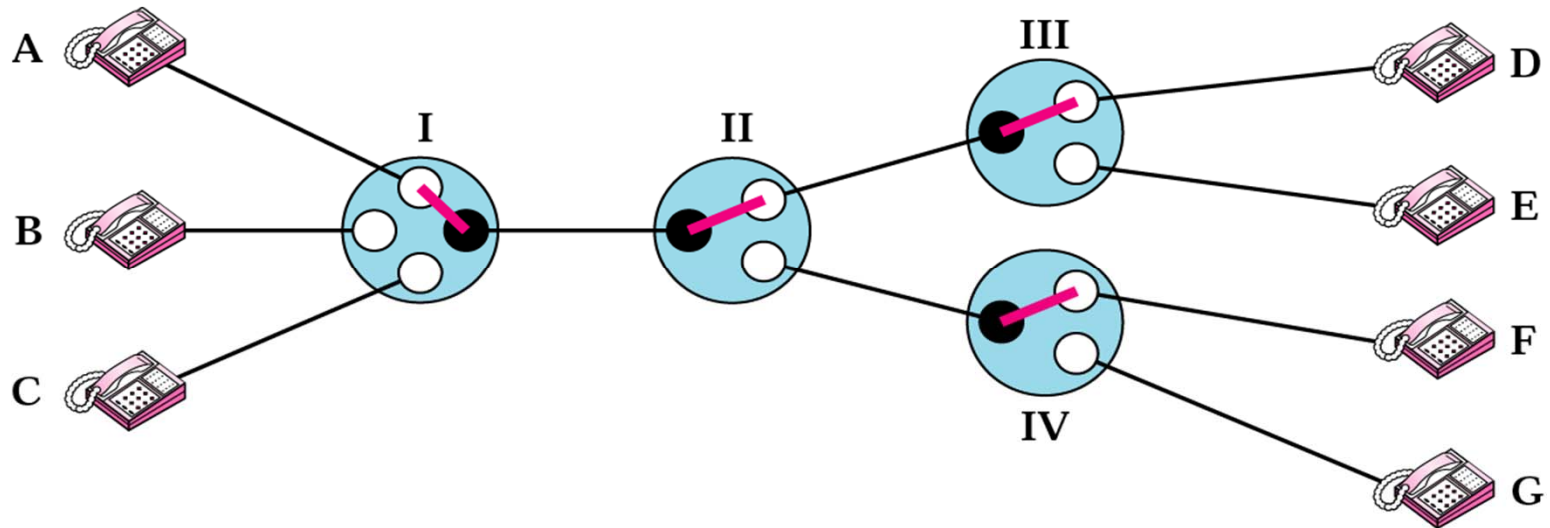

# Routing in Packet Switching Networks

- Key design issue for (packet) switched networks
- Select route across network between end nodes
- Characteristics required:
  - Correctness
  - Simplicity
  - Robustness
  - Stability
  - Fairness
  - Optimality
  - Efficiency

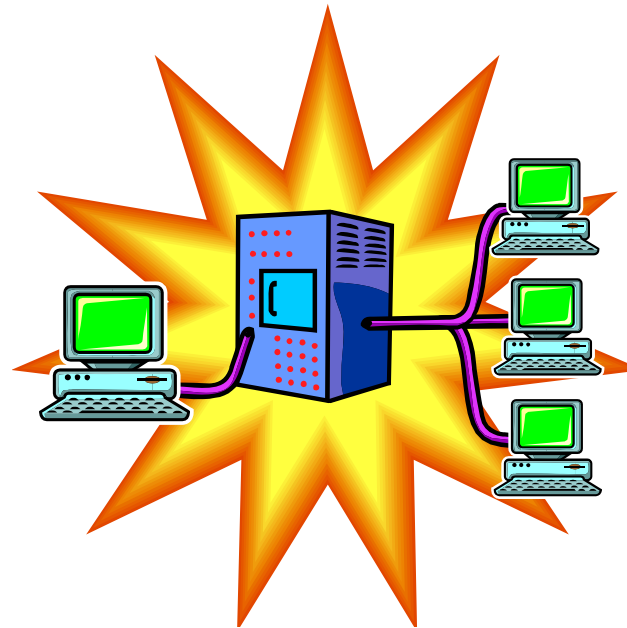

# Routing Strategies - Flooding

- Packet sent by node to every neighbor
- Eventually multiple copies arrive at destination
- No network information required
- Each packet is uniquely numbered so duplicates can be discarded
- Need to limit incessant retransmission of packets
  - Nodes can remember identity of packets retransmitted
  - Can include a hop count in packets



# Packet-switched Routing

## Choosing an optimal path

- According to a cost metric
- Decentralised: **each router has full/necessary information**

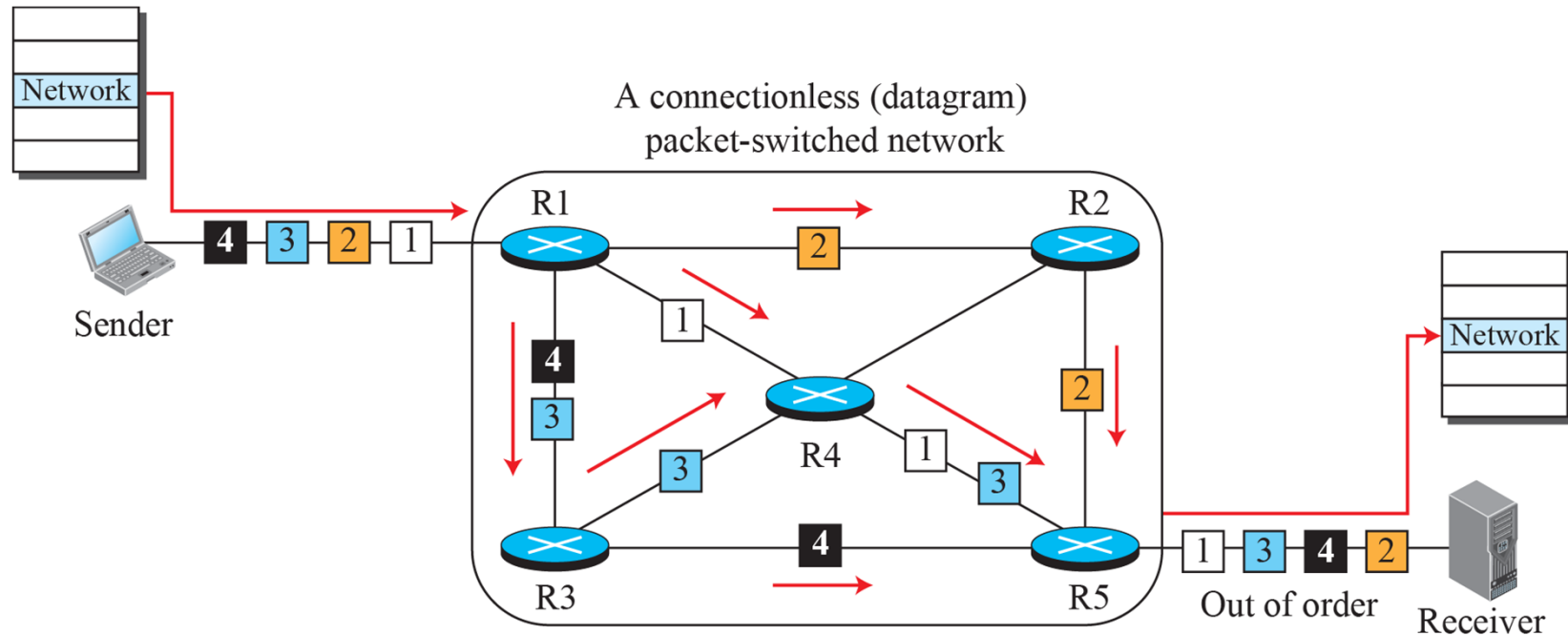

# Router

- Internetworking device
  - Passes data packets between networks
  - Checks **Network Layer** addresses
  - Uses Routing/forwarding tables

Two functions:

- 1 Routing
- 2 Forwarding

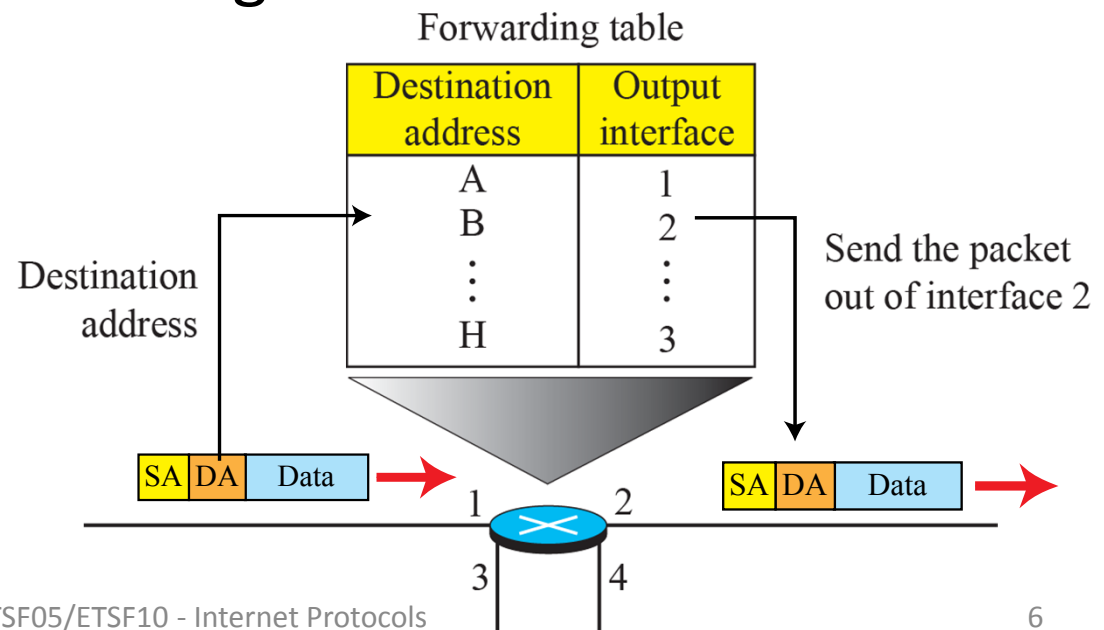

# Router Architecture Overview

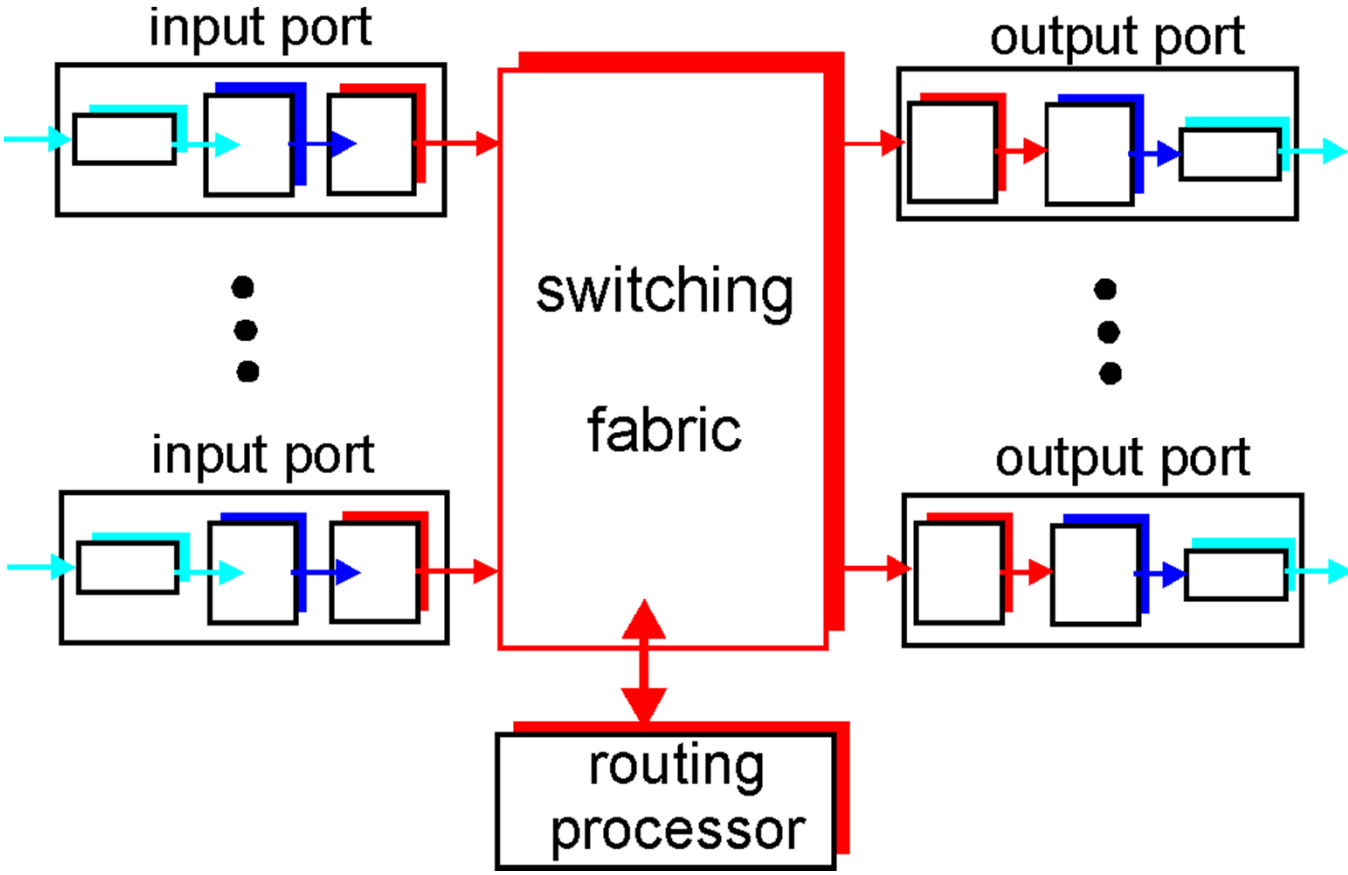

# Input Port

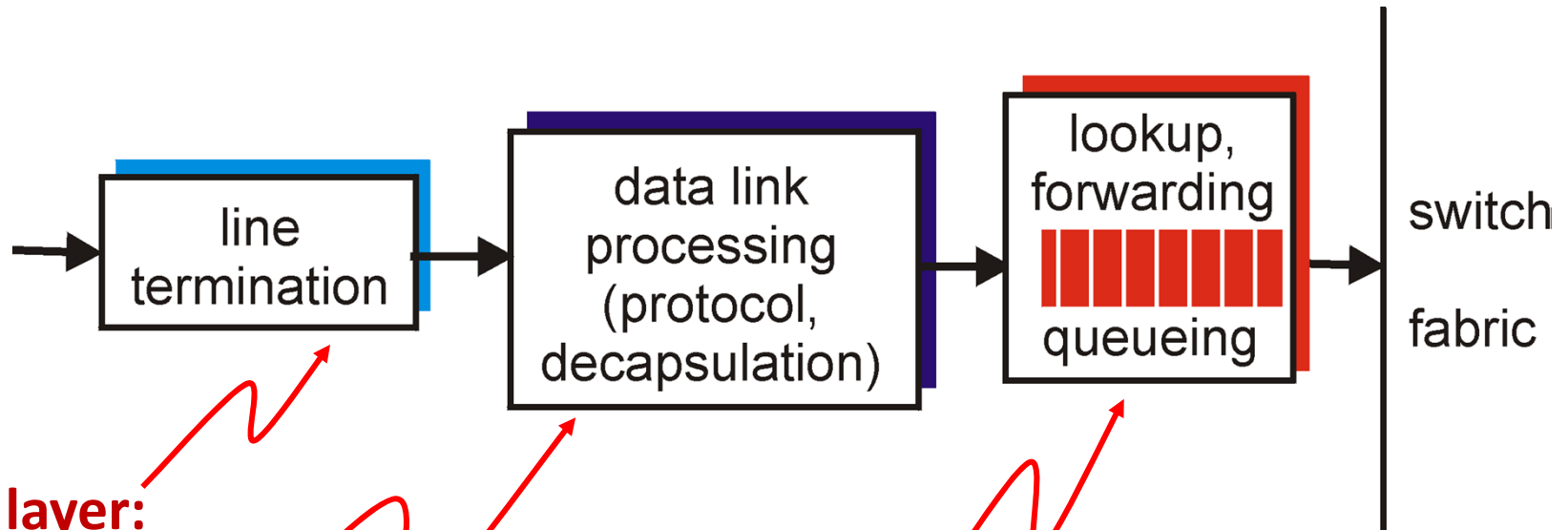

**Physical layer:**  
bit-level reception

**Data link layer:**  
e.g., Ethernet

## Decentralized switching:

- Given destination, lookup output port using routing table in input port memory
- Goal: complete input port processing at 'line speed'



# Input Port Queuing

- Fabric slower than sum of input ports → **queuing**
- **Delay and loss** due to input buffer overflow
- **Head-of-the-Line (HOL) blocking:** Datagram at front of queue prevents others in queue from proceeding

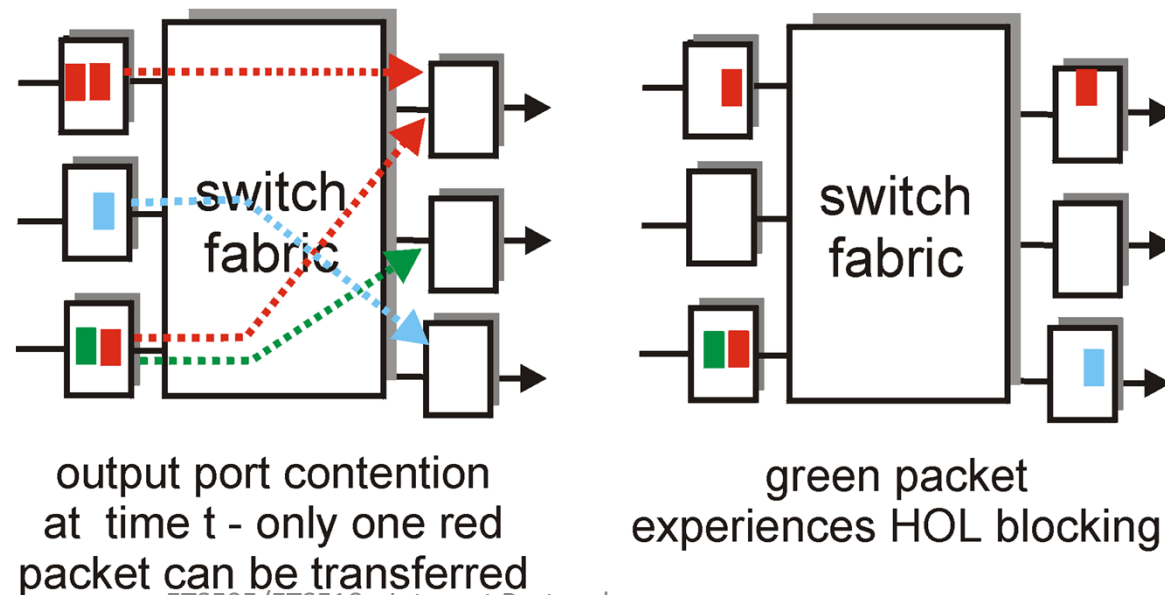

# Output Port

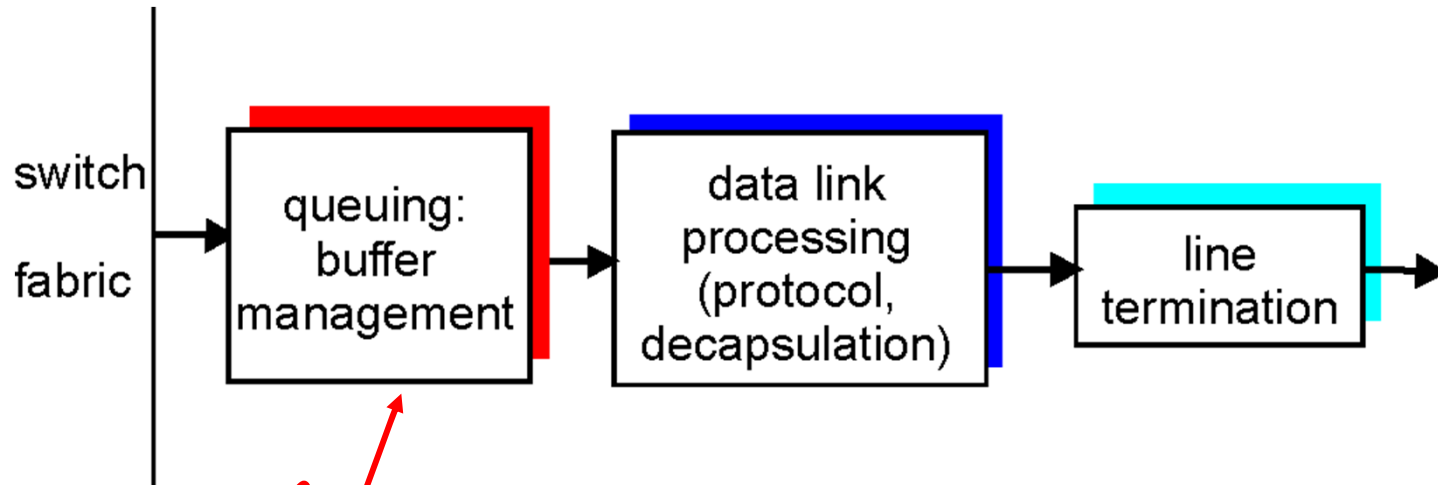

## Priority Scheduling:

- Scheduling discipline may choose among queued datagrams for transmission

# Switching Fabrics

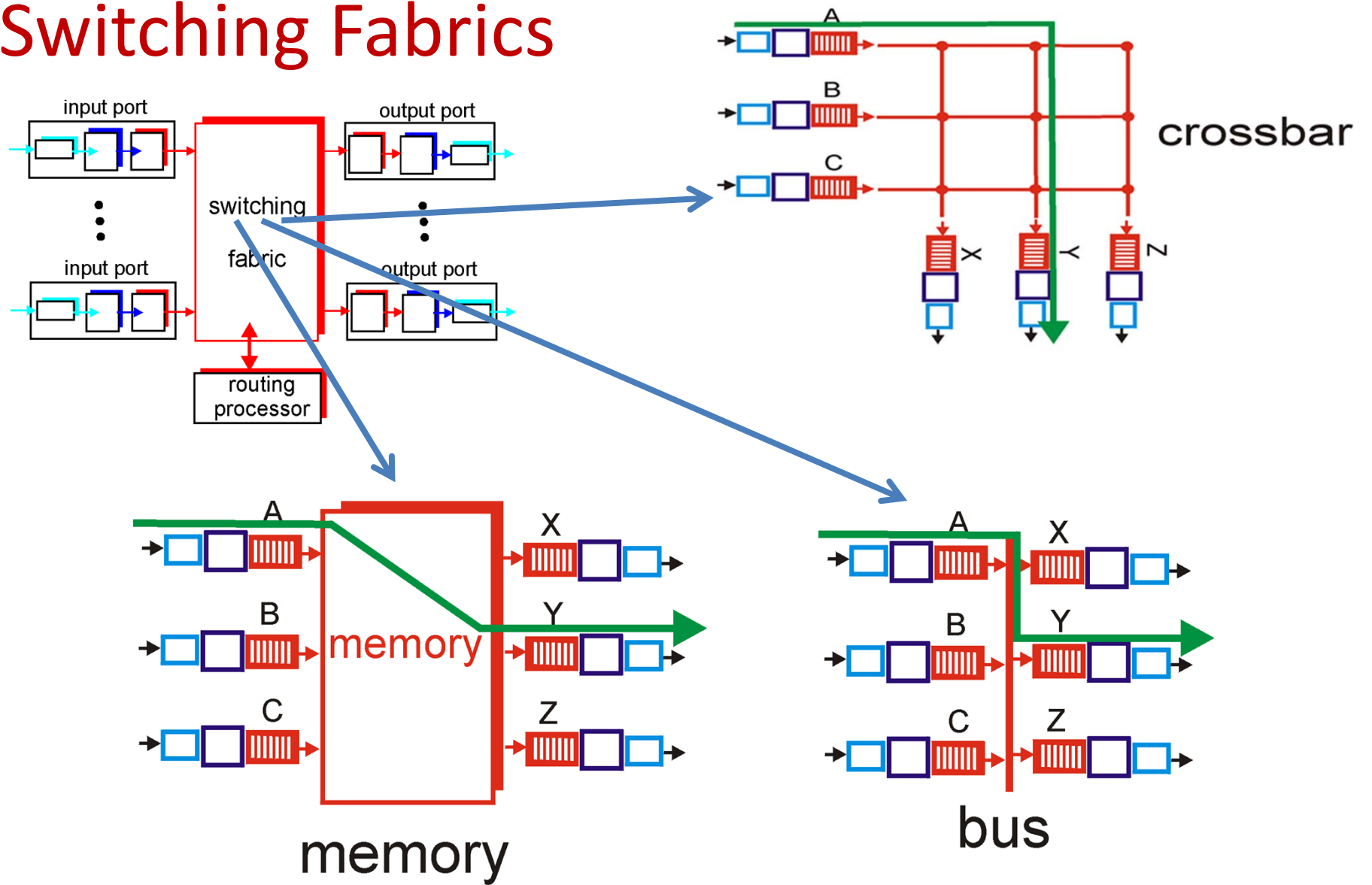

# Routing Tables and Forwarding Table

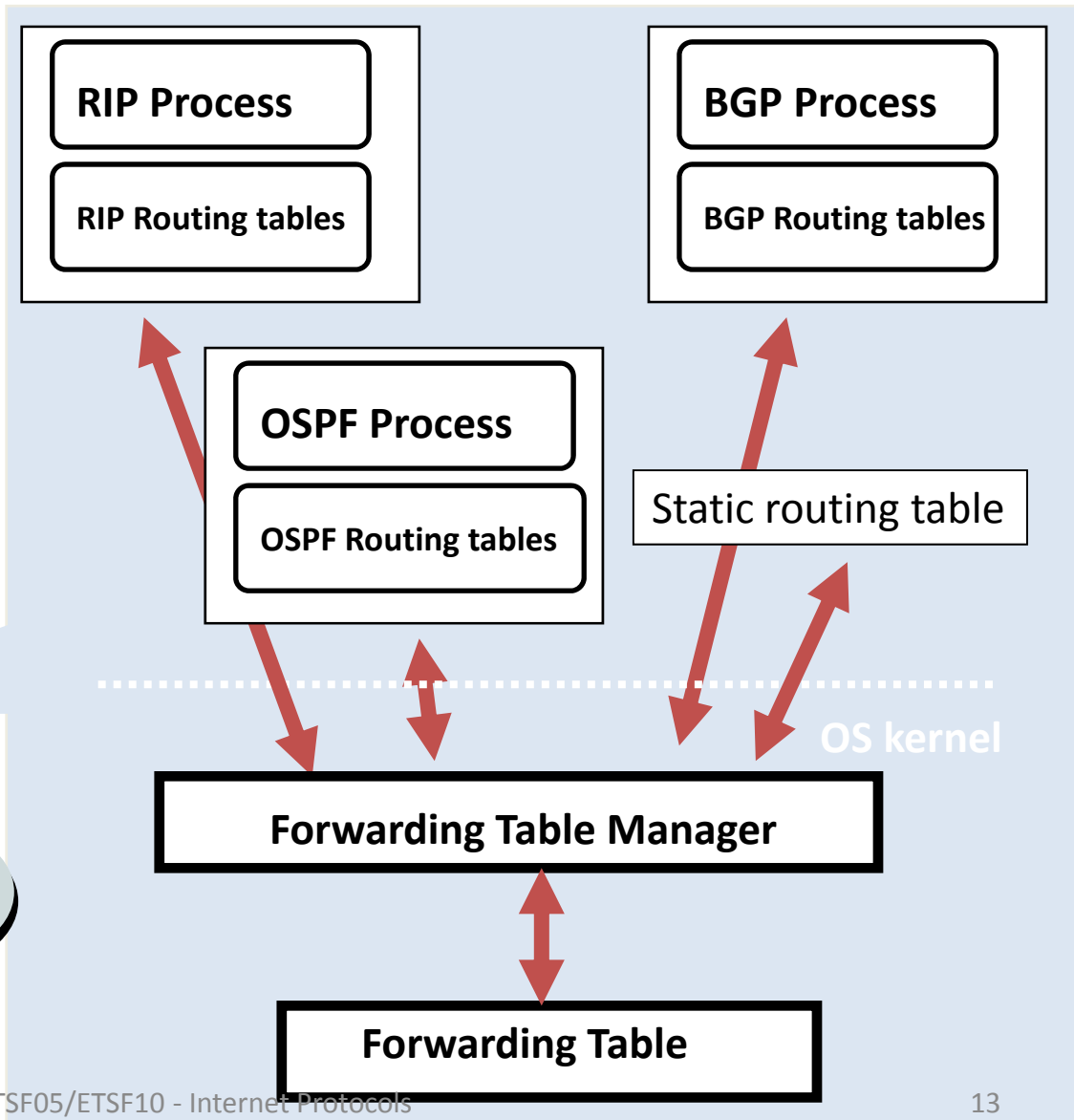
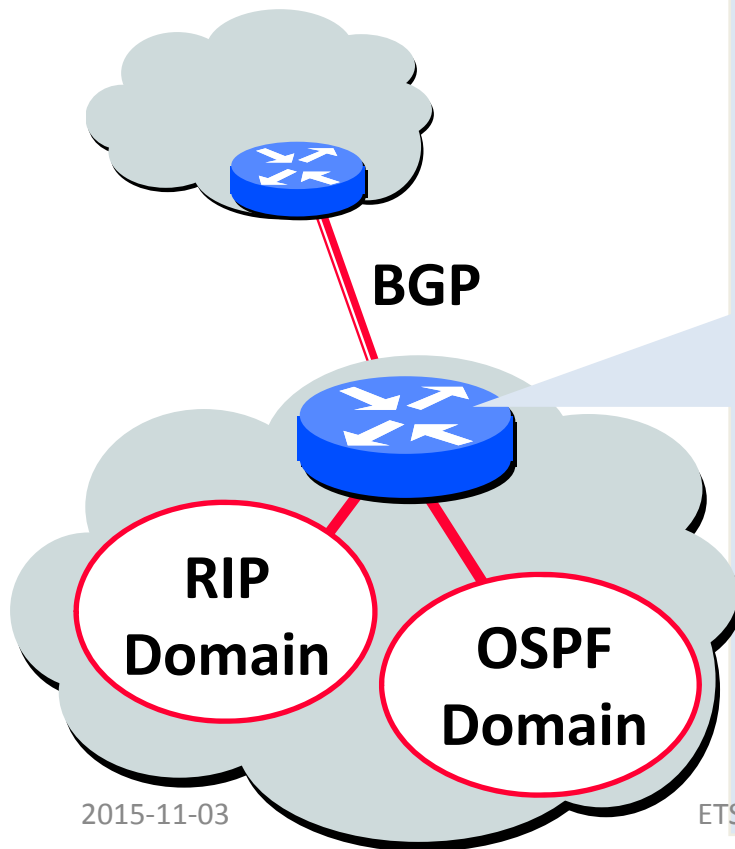
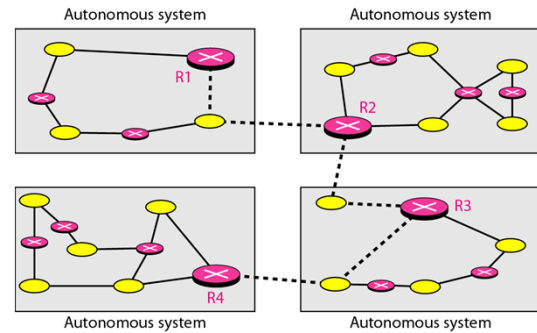

# Performance Criteria

- Used for selection of route
- Simplest is to choose “**minimum hop**”
- Can be generalized as “**least cost**” routing
- Because “least cost” is more flexible it is more common than “minimum hop”

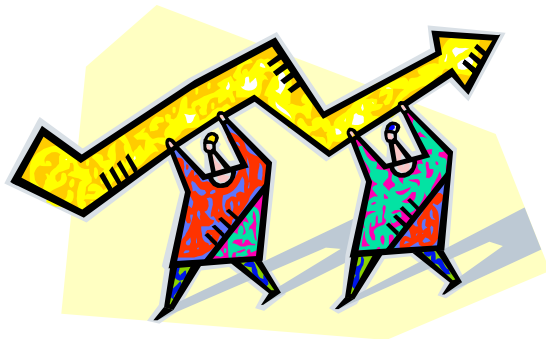

# Best Path: Decision Time and Place

## Decision time (when?)

- Packet or virtual circuit basis
- Fixed or dynamically changing

## Decision place (where?)

- Distributed - made by each node
  - More complex, but more robust
- Centralized – made by a designated node
- Source – made by source station

# Network Information Source and Update Timing

- Routing decisions usually based on knowledge of network, traffic load, and link cost
  - Distributed routing
    - Using local knowledge, information from adjacent nodes, information from all nodes on a potential route
  - Central routing
    - Collect information from all nodes

## Issue of update timing

- Depends on routing strategy
- Fixed - never updated
- Adaptive - regular updates

# Routing Strategies - Fixed Routing

- Use a **single permanent** route for each source to destination pair of nodes
- Determined using a least cost algorithm
- **Route is fixed**
  - Until a change in network topology
  - Based on expected traffic or capacity
- Advantage is **simplicity**
- Disadvantage is **lack of flexibility**
  - Does not react to network failure or congestion



# Routing Strategies - Adaptive Routing

- Used by almost all packet switching networks
- **Routing decisions change as conditions on the network change due to failure or congestion**
- **Requires information about network**

---

Disadvantages: Decisions more complex

---

Tradeoff between quality of network information and overhead

---

Reacting too quickly can cause oscillation

---

Reacting too slowly means information may be irrelevant

# Classification of Adaptive Routing Strategies

- A convenient way to classify is on the basis of information source

## Local (isolated)

- Route to outgoing link with shortest queue
- Can include bias for each destination
- Rarely used - does not make use of available information

## Adjacent nodes

- Takes advantage of delay and outage information
- Distributed or centralized

## All nodes

- Like adjacent

# ARPANET Routing Strategies

## 1st Generation

### Distance Vector Routing

- **1969**
- Distributed adaptive using **estimated delay**
  - Queue length used as estimate of delay
- Version of **Bellman-Ford** algorithm
- **Node exchanges delay vector with neighbors**
- **Update routing table based on incoming information**
- **Doesn't consider line speed**, just queue length and responds slowly to congestion

# ARPANET Routing Strategies

## 2nd Generation

### Link-State Routing

- **1979**
- Distributed adaptive using **delay** criterion
  - Using timestamps of arrival, departure and ACK times
- Re-computes average delays every 10 seconds
- **Any changes are flooded to all other nodes**
- Re-computes routing using **Dijkstra's algorithm**
- Good under light and medium loads
- Under heavy loads, little correlation between reported delays and those experienced

# ARPANET Routing Strategies

## 3rd Generation

- **1987**
- Link cost calculation changed
  - Damp routing oscillations
  - Reduce routing overhead
- Measure average delay over last 10 seconds and transform into link utilization estimate
- Normalize this based on current value and previous results
- **Set link cost as function of average utilization**

# Autonomous Systems (AS)

- Exhibits the following characteristics:
  - Is a set of routers and networks managed by a single organization
  - Consists of a group of routers exchanging information via a common routing protocol
  - Except in times of failure, is connected (in a graph-theoretic sense); there is a path between any pair of nodes

# Interior Router Protocol (IRP)

## Interior Gateway Protocol (IGP)

- A shared routing protocol which passes routing information between routers within an AS
- Custom tailored to specific applications and requirements

### Examples

- *Routing Information Protocol (RIP)*
- *Open Shortest Path First (OSPF)*

# Exterior Router Protocol (ERP)

## Exterior Gateway Protocol (EGP)

- Protocol used to pass routing information between routers in different ASs
- Will need to pass less information than an IRP for the following reason:
  - If a datagram is to be transferred from a host in one AS to a host in another AS, a router in the first system need only determine the target AS and devise a route to get into that target system
  - Once the datagram enters the target AS, the routers within that system can cooperate to deliver the datagram
  - The ERP is not concerned with, and does not know about, the details of the route

### Examples

- *Border Gateway Protocol (BGP)*
- *Open Shortest Path First (OSPF)*



# Graphical representation of a net

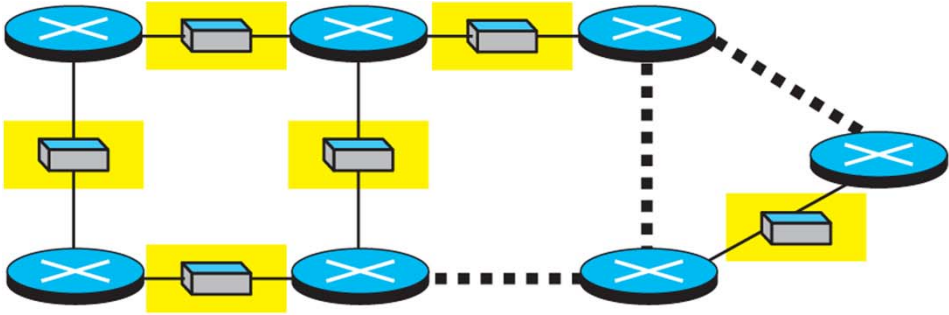
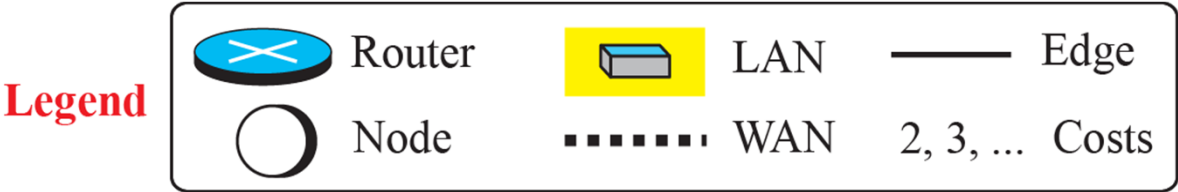

a. An internet

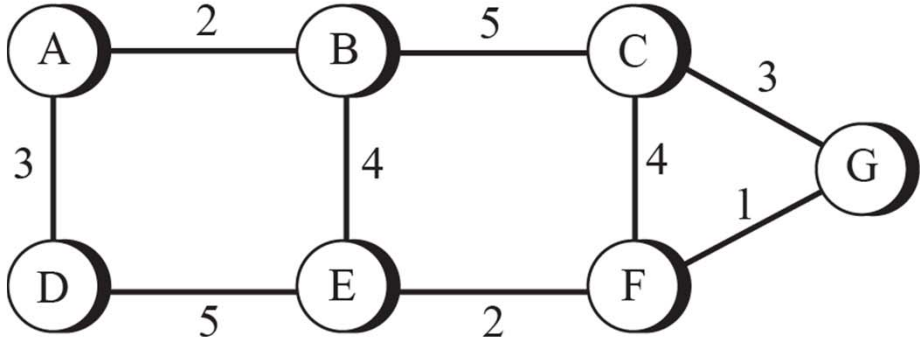

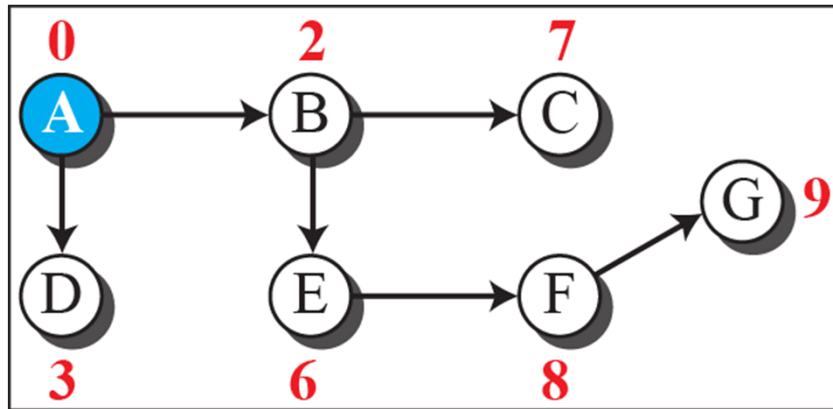

b. The weighted graph

# What is an end node?



## Legend

-  Root of the tree
-  Intermediate or end node
- 1, 2, ...** Total cost from the root

**Problem: The LANs are our destinations/end nodes, not the routers**

# A more realistic representation

- Solution: Nets and routers are all nodes in the tree.
- Routers hold tables how to reach nets and what is the *next hop* for to get there

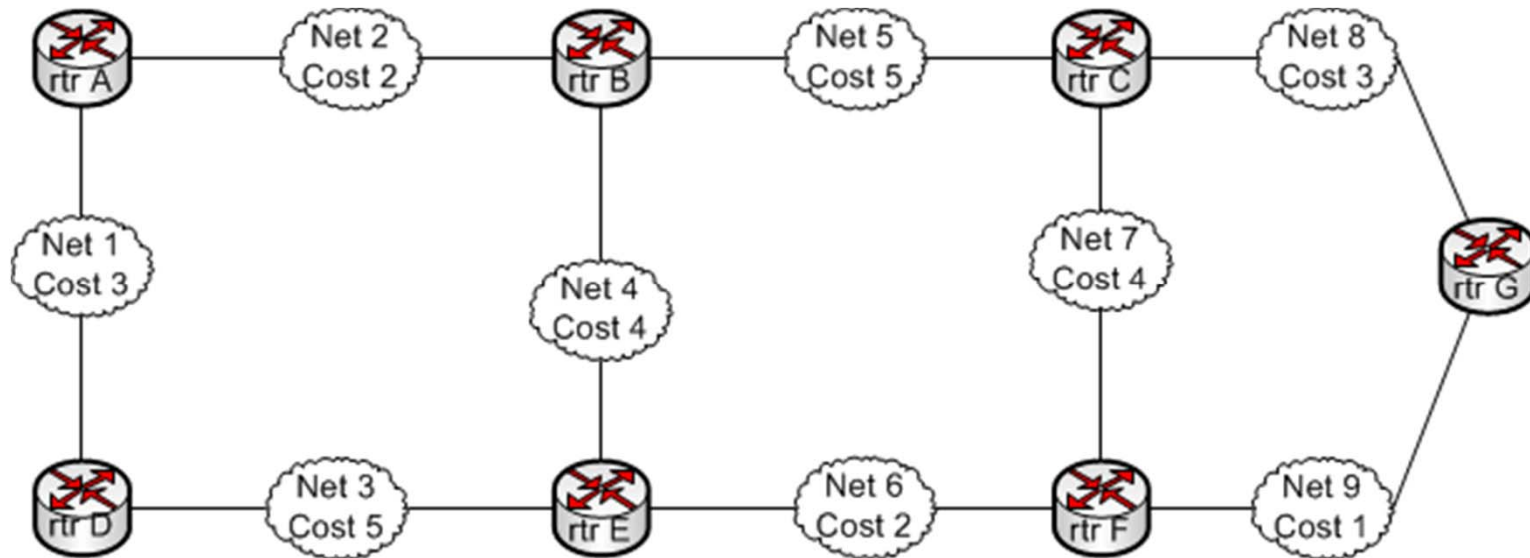

# Routing Algorithms and Protocols

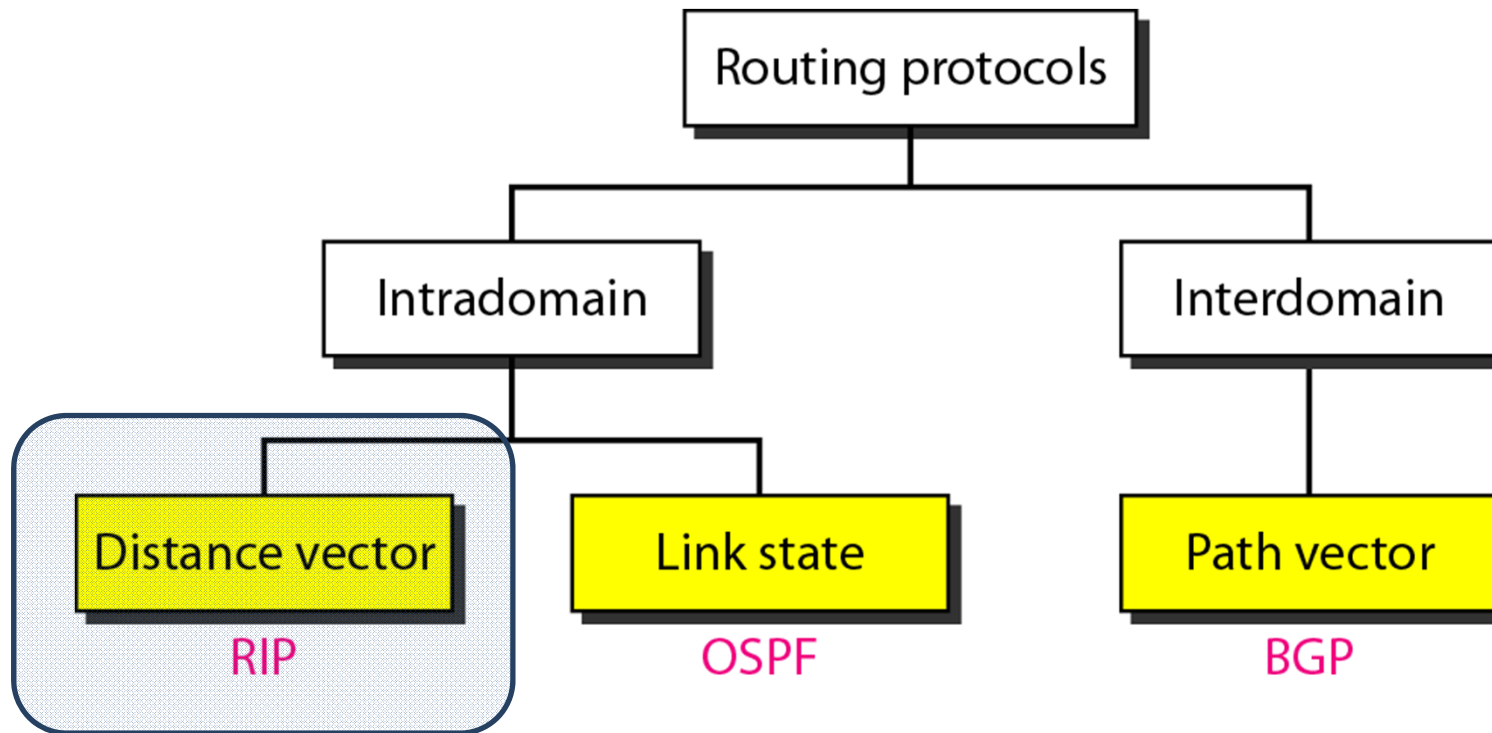

# Distance-Vector Routing

- Requires that each node exchange information with its neighboring nodes
  - Two nodes are said to be neighbors if they are both directly connected to the same network
- Used in the first-generation routing algorithm for ARPANET
- Each node maintains a vector of link costs for each directly attached network and distance and next-hop vectors for each destination
- Routing Information Protocol (RIP) uses this approach

# RIP (Routing Information Protocol)

- Included in BSD-UNIX Distribution in 1982
- Distance metric:
  - **# of hops** (max 15) to destination network
- Distance vectors:
  - exchanged among neighbours every 30" via Response Message (advertisement)
- Implementation:
  - Application layer protocol, uses UDP/IP

# A RIP Forwarding/Routing Table

Destination=net	Cost	Next hop=router
123	3	A
32	5	D
16	3	A
7	2	-

# RIP update message

- Contains the whole forwarding table
- Action on reception:
  - Add 1 to cost in received message
  - Change next hop to sending router
  - Apply RIP updating algorithm
- **IMPORTANT!** Received update msgs identify neighbours!



# RIP Updating Algorithm (Bellman-Ford)

```
if (advertised destination not in table)
{
  add new entry // rule #1
}
else if (adv. next hop = next hop in table)
{
  update cost // rule #2
}
else if (adv. cost < cost in table)
{
  replace old entry // rule #3
}
```

# RIP Example



# Two node instability/Count to infinity

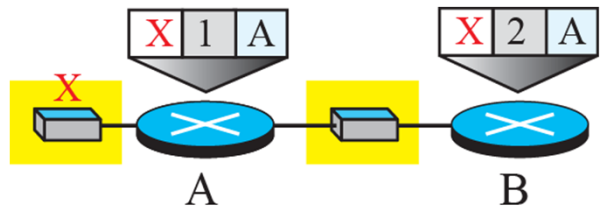

a. Before failure

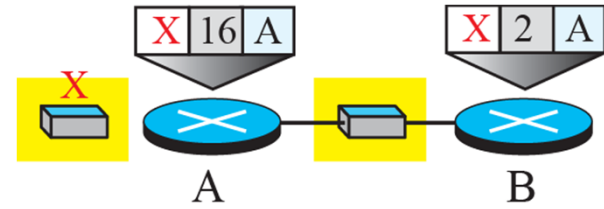

b. After link failure

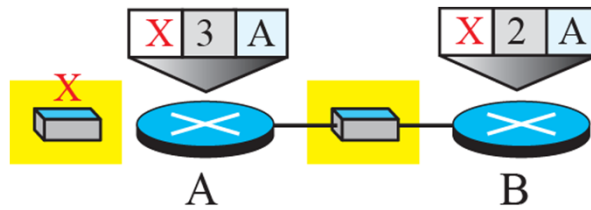

c. After A is updated by B

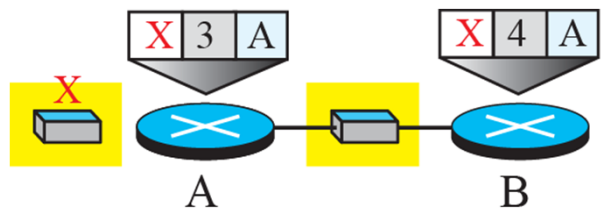

d. After B is updated by A

...

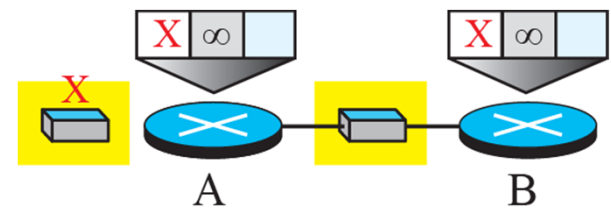

e. Finally

# Split Horizon breaks Count to infinity

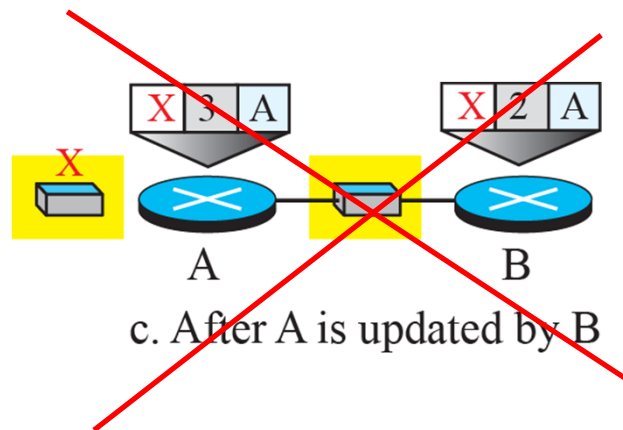
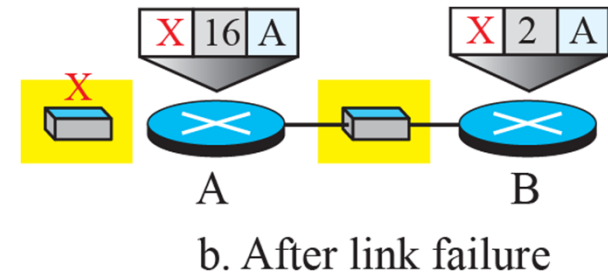
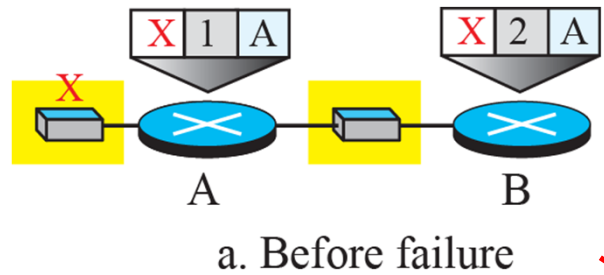

I have a route to X, but I got it from A so I won't tell A about it!

# RIP: Link Failure and Recovery

- If no advertisement heard after 180”
  - Neighbour/link declared dead
  - Routes via neighbour invalidated (infinite distance = 16 hops)
  - New advertisements sent to neighbours (triggering a chain reaction if tables changed)
  - “Poison reverse” used to prevent count to infinity loops
  - “Good news travel fast, bad news travel slow”

# Routing Algorithms and Protocols

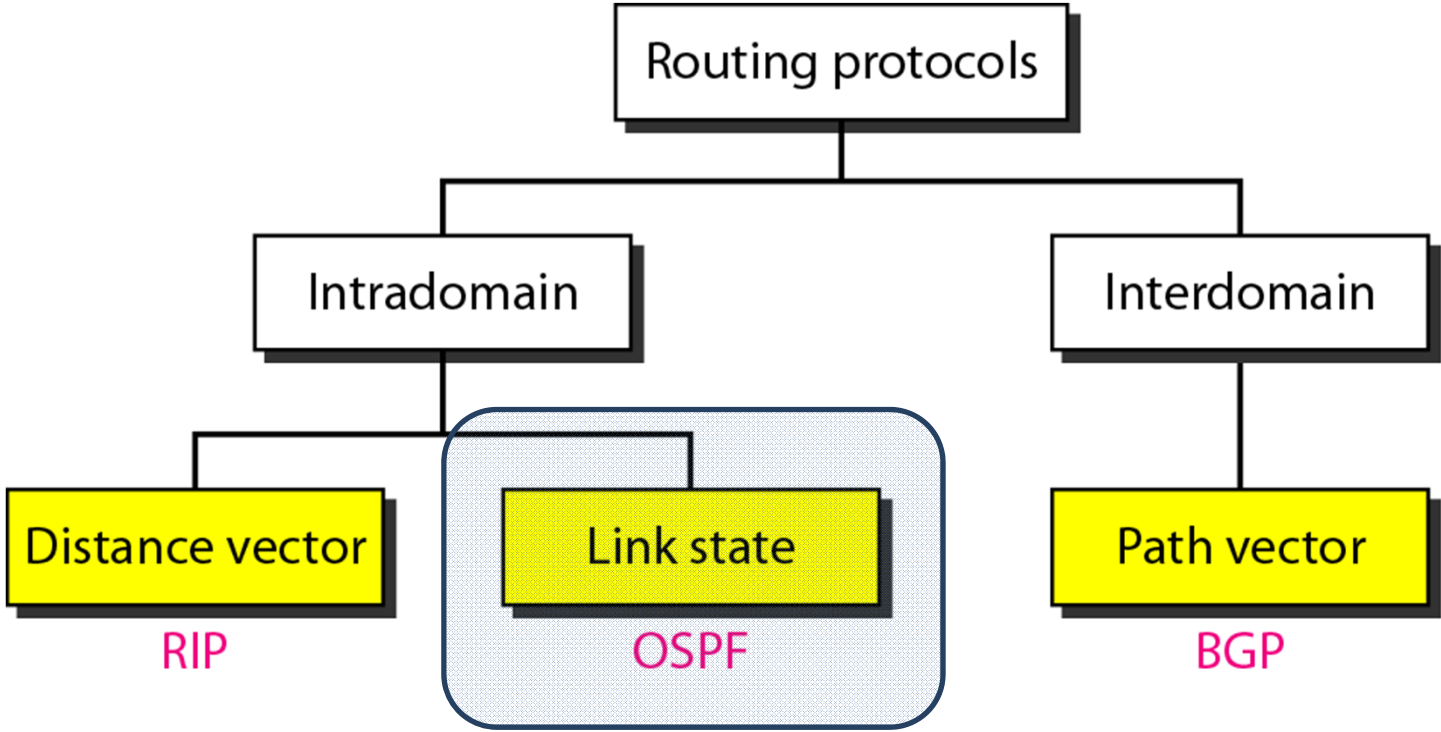

# Link-State Routing

- Designed to overcome the drawbacks of distance-vector routing
- When a router is initialized, it determines the link cost on each of its network interfaces
- The router then advertises this set of link costs to all other routers in the internet topology, not just neighboring routers
- From then on, the router monitors its link costs
- Whenever there is a significant change the router again advertises its set of link costs to all other routers in the configuration
- The OSPF protocol is an example
- The second-generation routing algorithm for ARPANET also uses this approach

# Open Shortest Path First (OSPF) Protocol

- RFC 2328
- Used as the interior router protocol in TCP/IP networks
- Computes a route through the internet that incurs the least cost based on a user-configurable metric of cost
- Is able to equalize loads over multiple equal-cost paths



# OSPF (Open Shortest Path First)

- Divides domain into areas
  - Limits flooding for efficiency
  - One "backbone" area connects all
- Distance metric:
  - Cost to destination network

# Areas, Router and Link Types

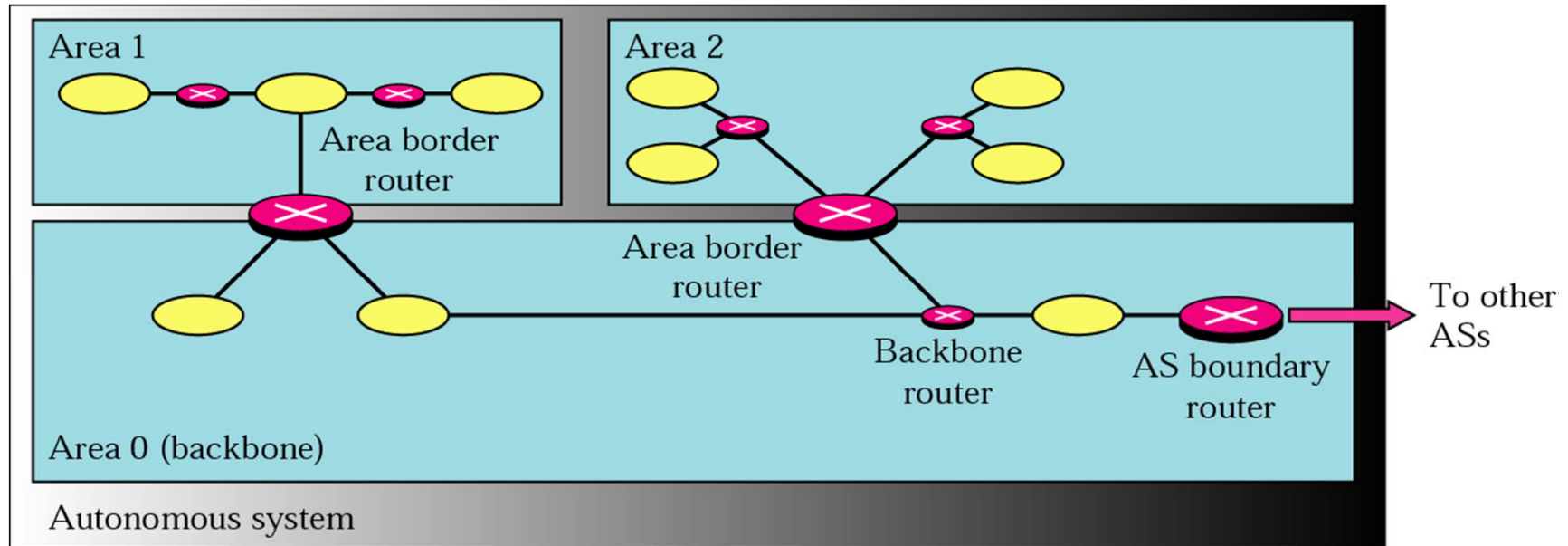

# Point-to-Point Link

- Connects two routers
- No need for addresses

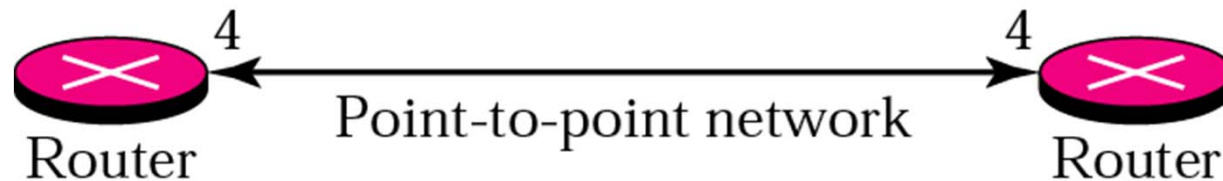
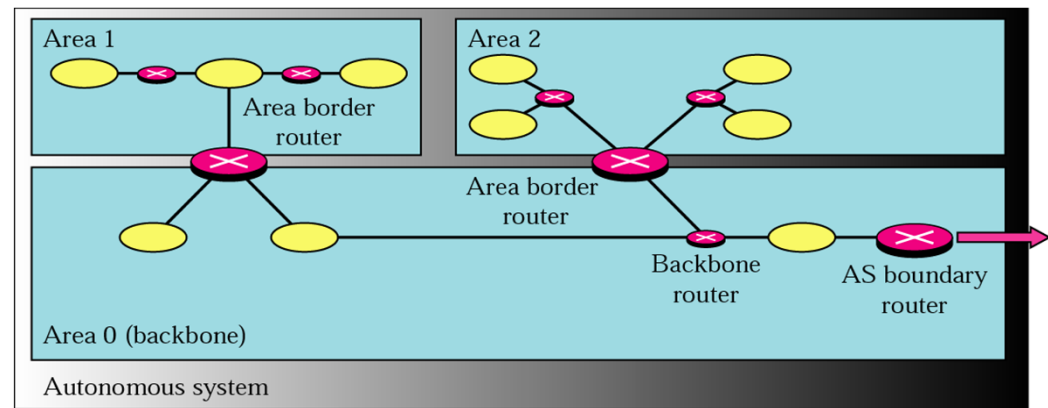

# Transient Link

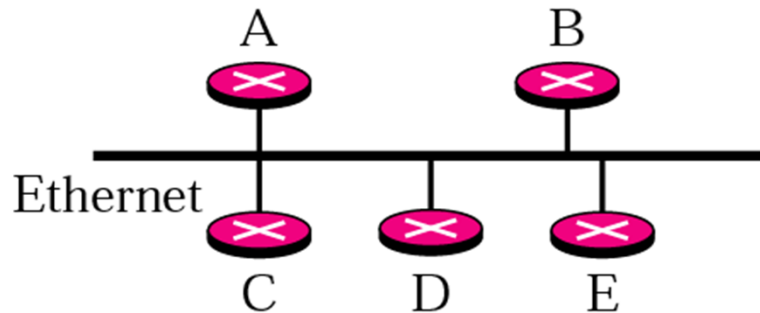
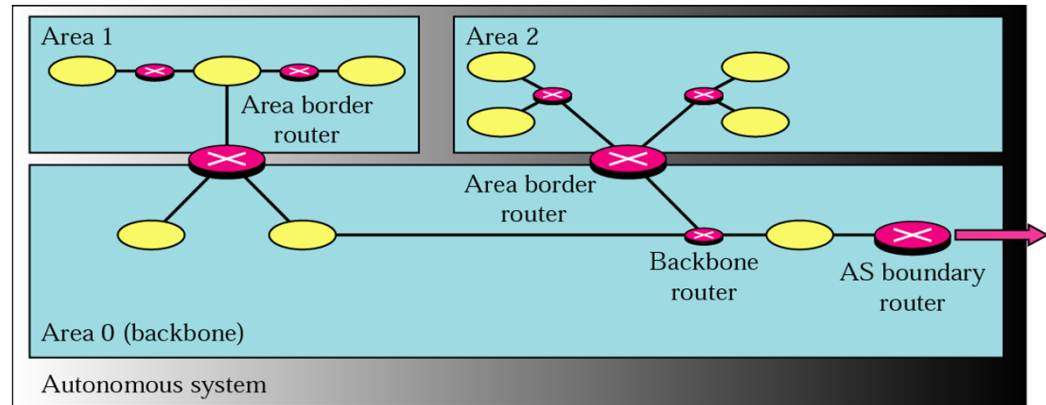

a. Transient network

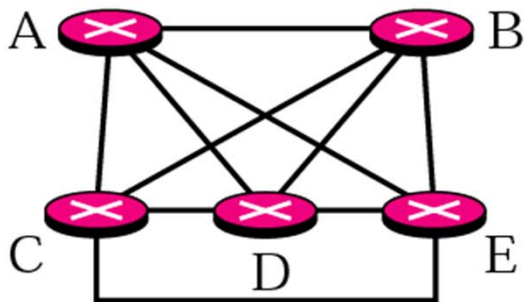

b. Unrealistic representation

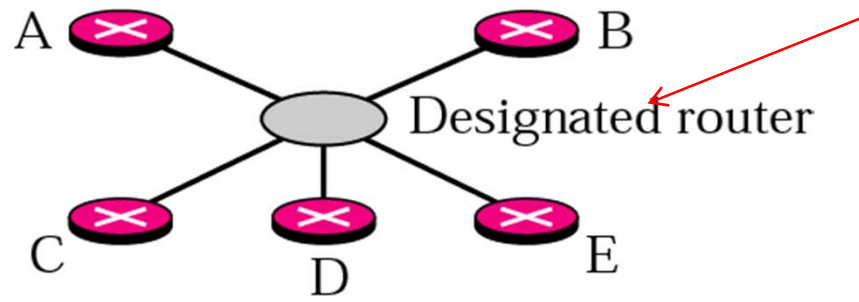

c. Realistic representation

# Stub Link

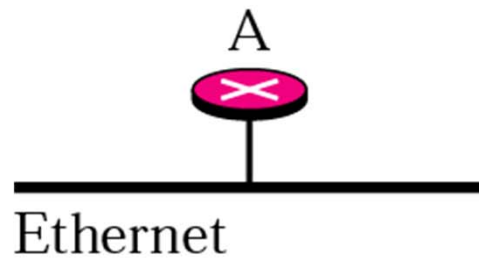
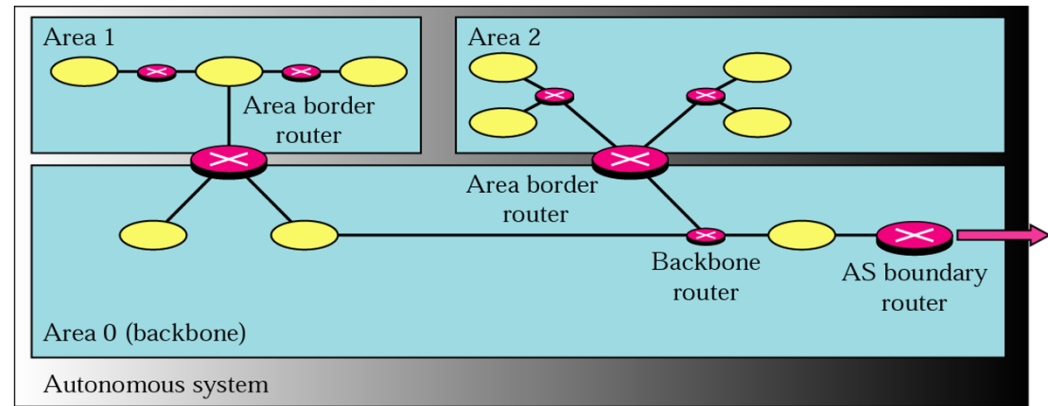

a. Stub network



b. Representation

# Link State Advertisements

- What to advertise?
  - Different entities as nodes
  - Different link types as connections
  - Different types of cost

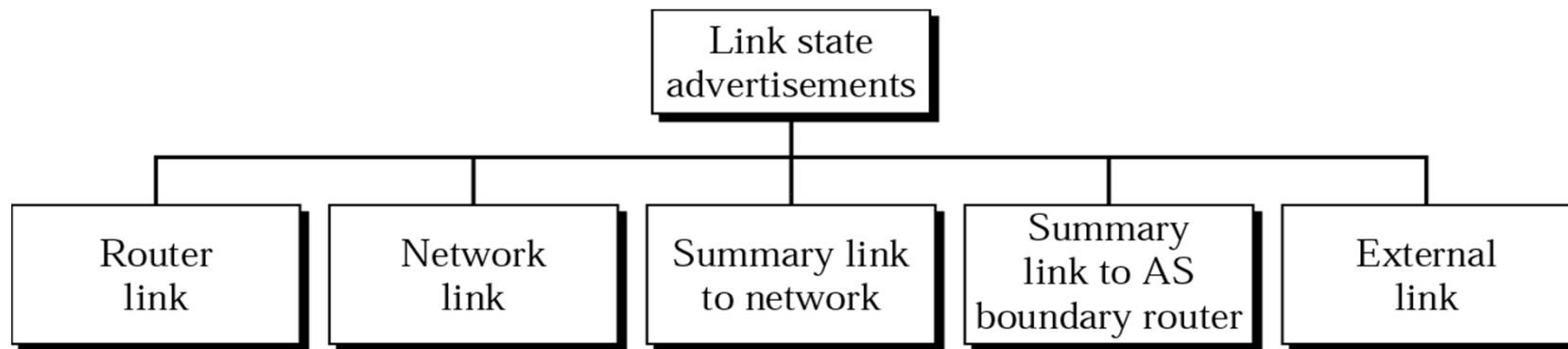

# Router Link Advertisement

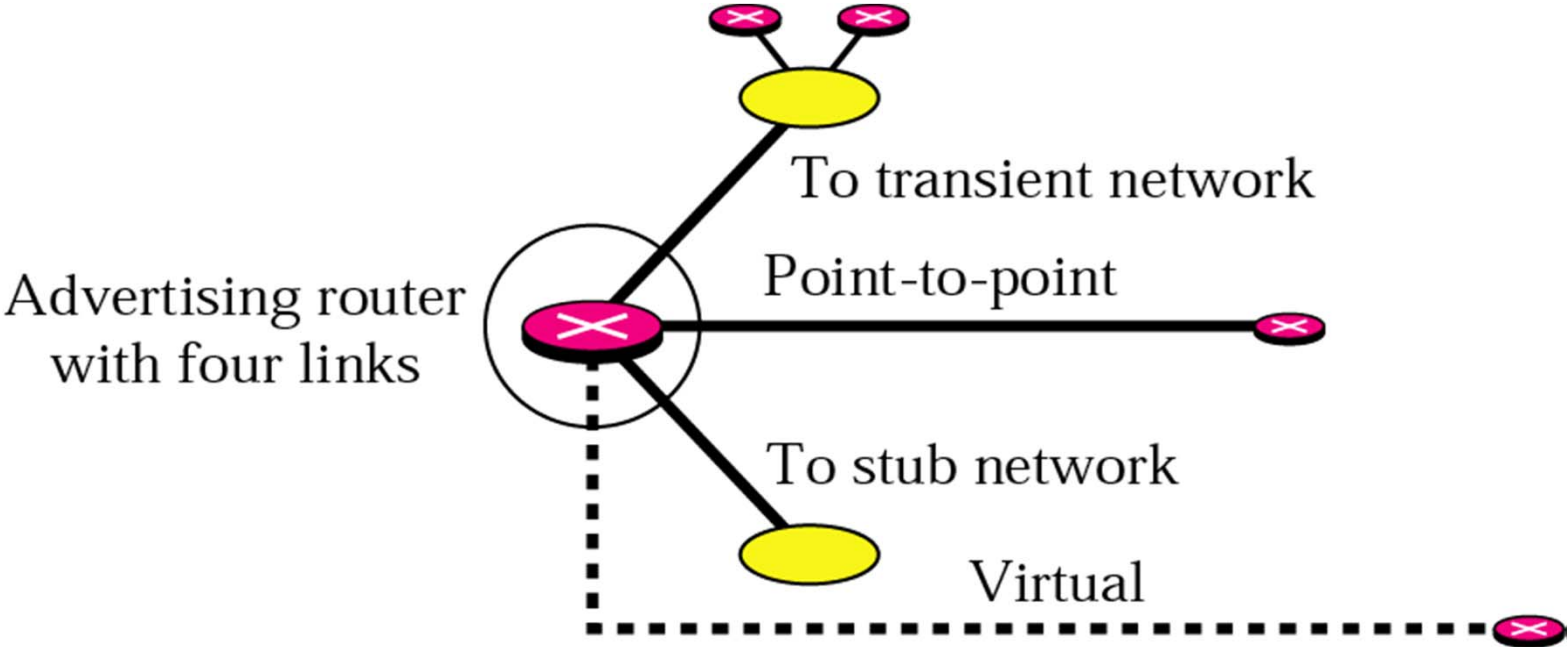

# Network Link Advertisement

- Network is a passive entity
  - It cannot advertise itself

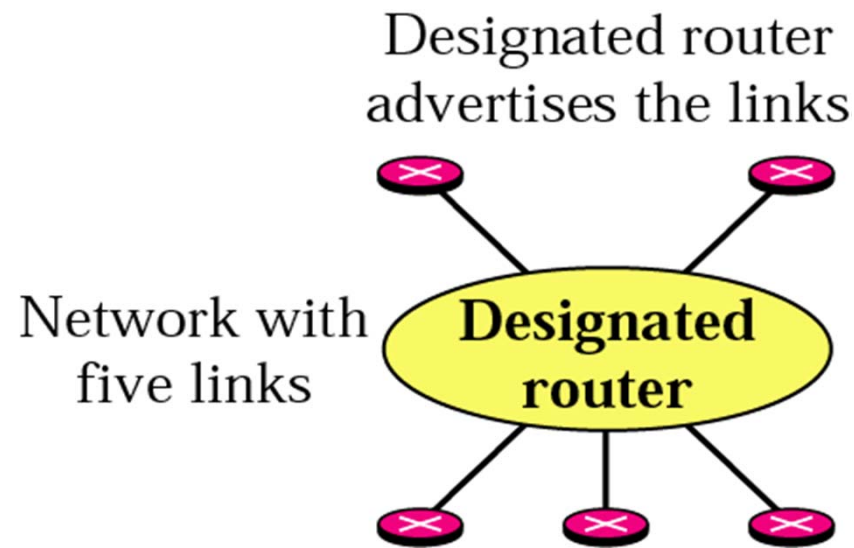



# Summary Link to Network

- Done by area border routers
  - Goes through the backbone

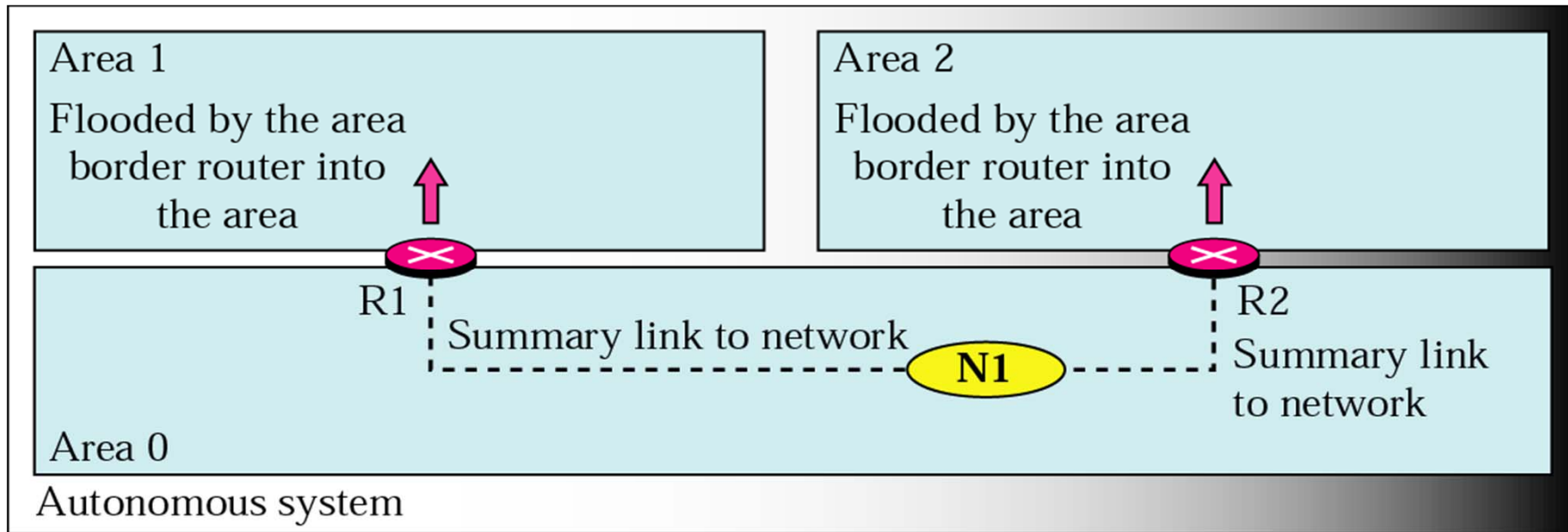

# Summary Link to AS Boundary Router

- Links to other domains  
"autonomous systems"

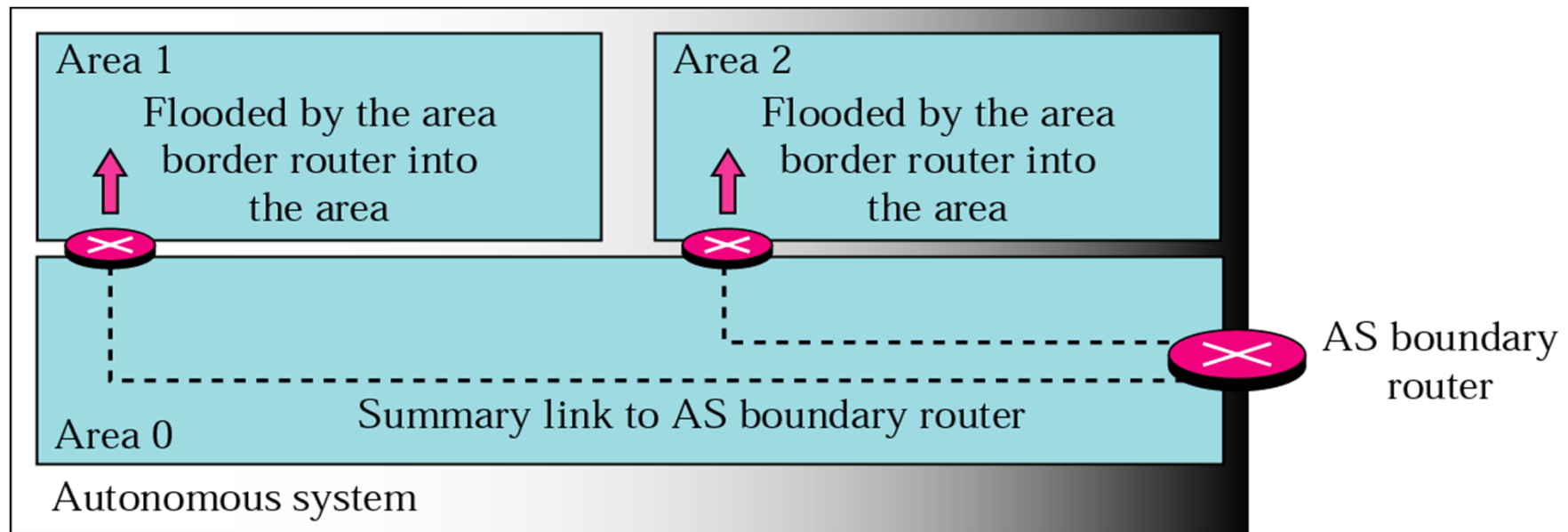

# External Link Advertisement

- Link to a single network outside the domain

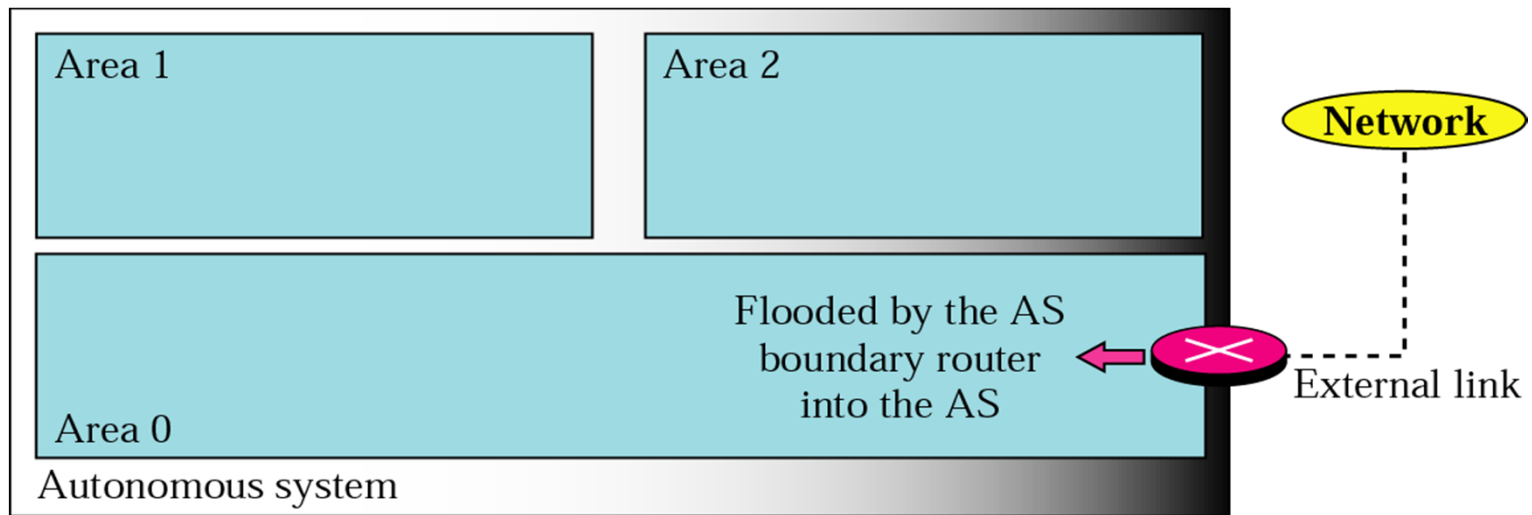

# Hello message

- Find neighbours
- Keep contact with neighbours: I am still alive!
- Sent out periodically (typically every 10th second)
- If no hellos received during holdtime (typically 30 seconds), neighbour declared dead.
  
- Compare RIP update messages

# Dijkstra's Algorithm

- Finds shortest paths from given source node to all other nodes
- Develop paths in order of increasing path length
- Algorithm runs in stages
  - Each time adding node with next shortest path
- Algorithm terminates when all nodes have been added to  $T$



Destination	Next Hop	Distance
N1	R3	10
N2	R3	10
N3	R3	7
N4	R3	8
N6	R10	8
N7	R10	12
N8	R10	10
N9	R10	11
N10	R10	13
N11	R10	14
H1	R10	21
R5	R5	6
R7	R10	8
N12	R10	10
N13	R5	14
N14	R5	14
N15	R10	17

Table 19.3

Routing Table  
for R6

# Comparison

- Bellman-Ford
  - Calculation for node  $n$  needs link cost to neighboring nodes plus total cost to each neighbor from  $s$
  - Each node can maintain set of costs and paths for every other node
  - Can exchange information with direct neighbors
  - Can update costs and paths based on information from neighbors and knowledge of link costs

- Dijkstra
  - Each node needs complete topology
  - Must know link costs of all links in network
  - Must exchange information with all other nodes

