

ETSF05 – Internet Protocols

Layer 1 and 2

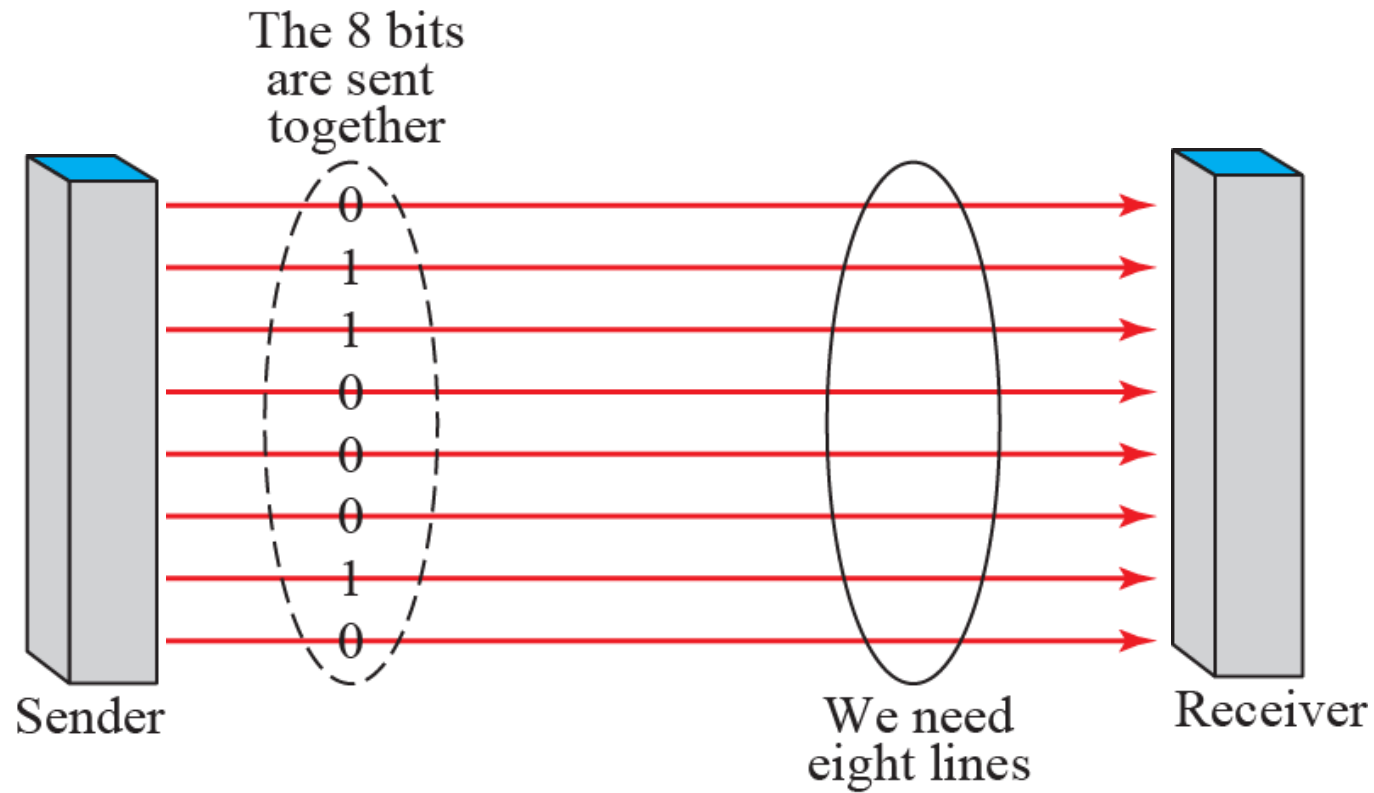

Parallel transmission



Serial transmission

Parallel/serial
converter

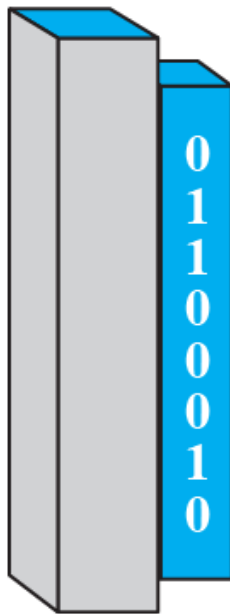

Sender

The 8 bits are sent
one after another.

0 1 1 0 0 0 1 0



We need only
one line (wire).

Serial/parallel
converter

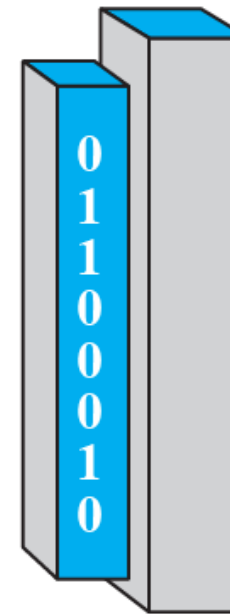

Receiver

Transmission modes

- Asynchronous

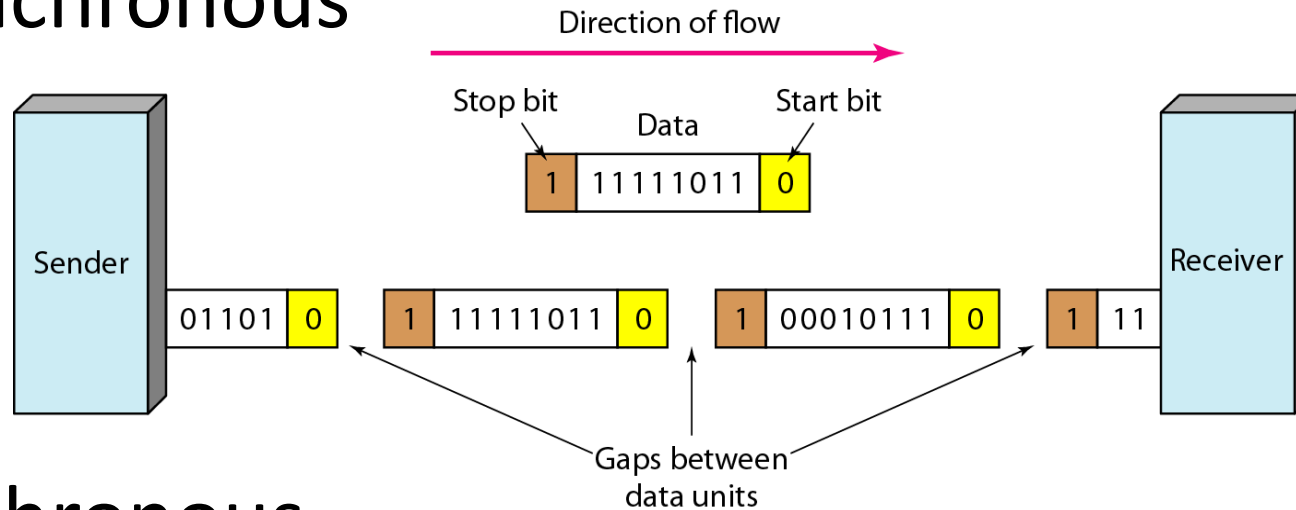

- Synchronous

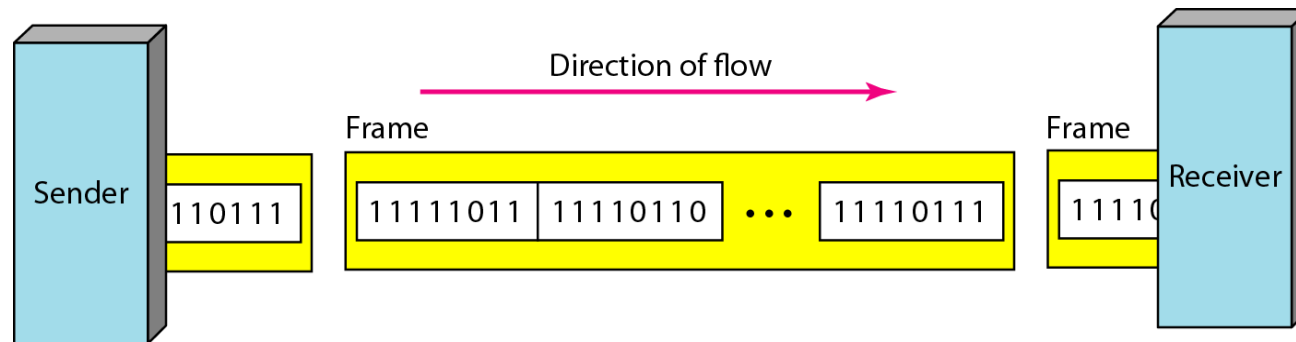

Multiplexing, princip

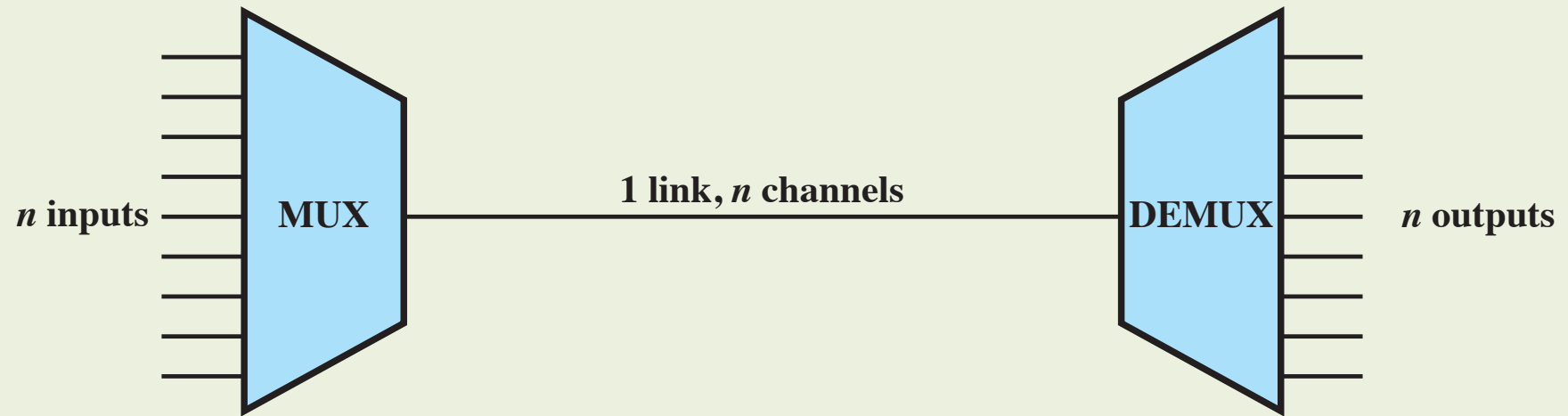

Figure 8.1 Multiplexing

Multiplexing in time/frequency

FDM Frequency Division Multiplexing



TDM Time Division Multiplexing

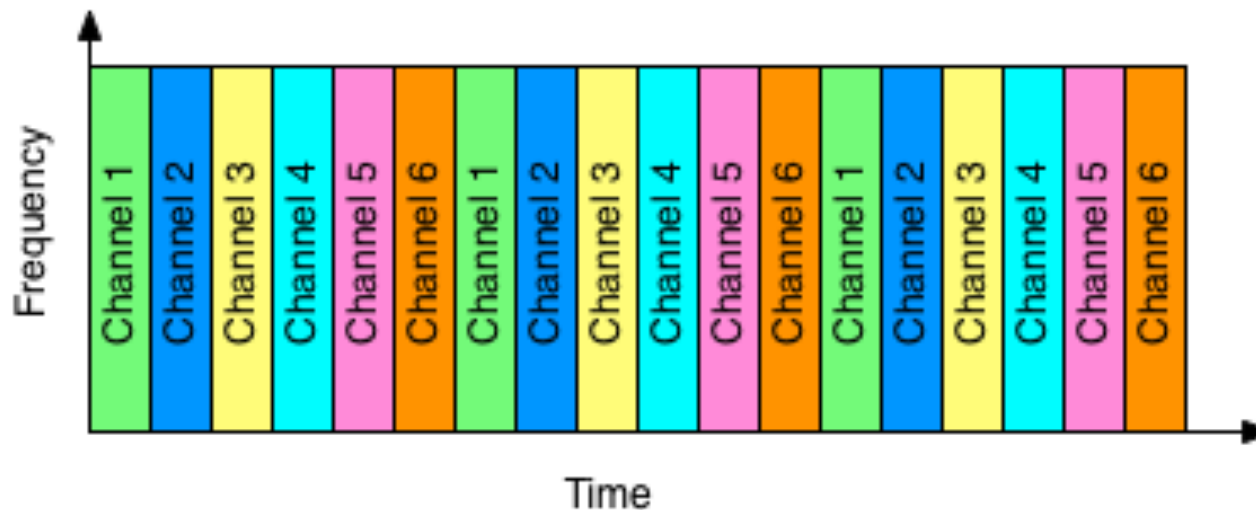

Synkron TDM

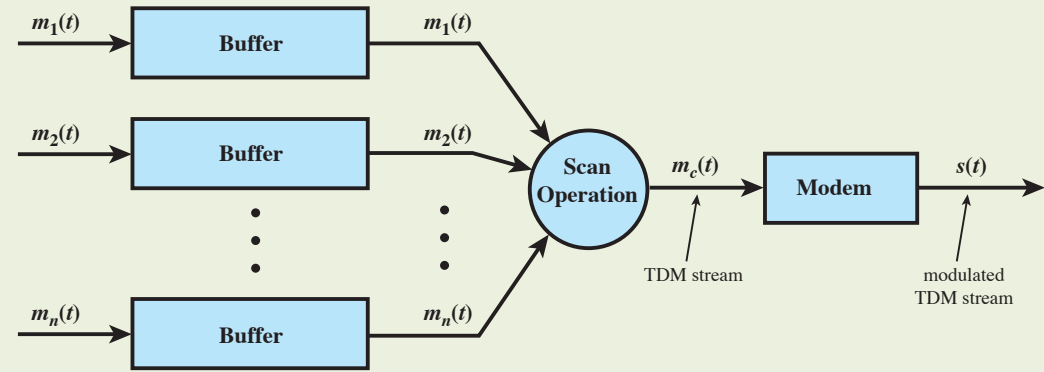

(a) Transmitter

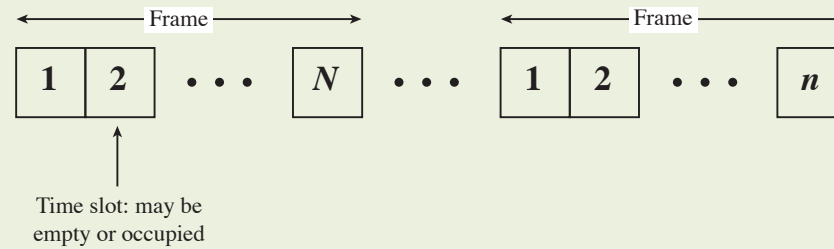

(b) TDM Frames

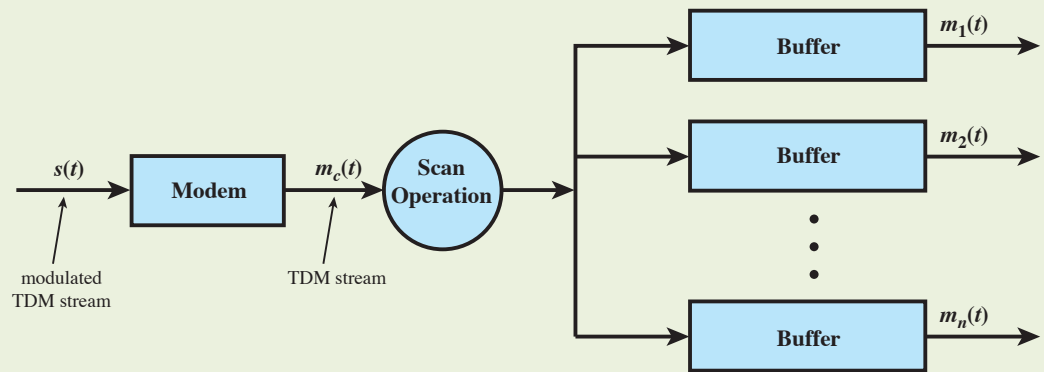

(c) Receiver

Figure 8.6 Synchronous TDM System

TDM Link Control

- Data link control protocols not needed
 - Time is control parameter
 - No headers and trailers
- Flow control
 - Data rate of multiplexed line is fixed
 - If one channel receiver can not receive data, the others must carry on. The corresponding source must be turned off, leaving empty slots for a while.
- Error control
 - Errors handled on individual channel

Synchronisation

- Problem of synchronizing various data sources
- Variation among clocks could cause loss of synchronization
- Issue of data rates from different sources not related by a simple rational number

Pulse Stuffing is a common solution

Have outgoing data rate (excluding framing bits) higher than sum of incoming rates

Stuff extra dummy bits or pulses into each incoming signal until it matches local clock

Stuffed pulses inserted at fixed locations in frame and removed at demultiplexer

Synchronisation

- Problem of synchronizing various data sources
 - E.g. variation or drift in clocks
- Common solution: Pulse stuffing
 - Outgoing data rate higher than sum of incoming rates
 - Stuff extra pulses (or bits) at predefined positions in the outgoing sequence
 - Pulses identified at the receiver, which can be used to synchronize with the transmitter.

Control of transmission

Simplex

- One way transmission

Half duplex

- Two way transmission, but not simultaneously

Full duplex

- Two way transmission

Duplexing

- FDD (Frequency Division Duplexing)
 - Separate Up-link and Down-link in frequency band
- TDD (Time Division Duplexing)
 - Separate Up-link and Down-link in time slots
- Electrical duplexing
 - Up and Down signals separated electrically using a hybrid circuit at both ends

Duplexing

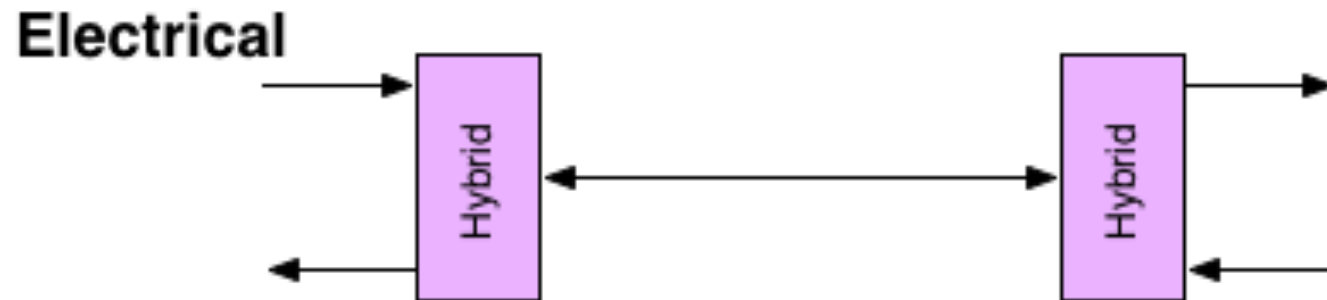
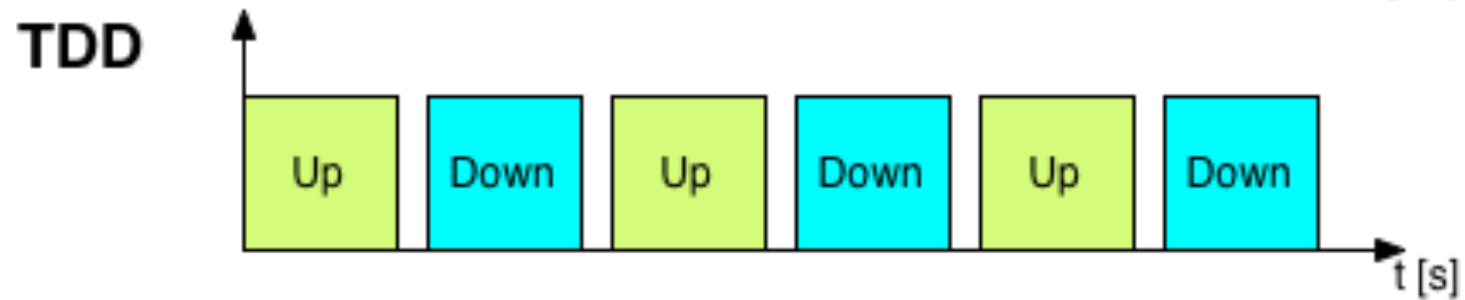
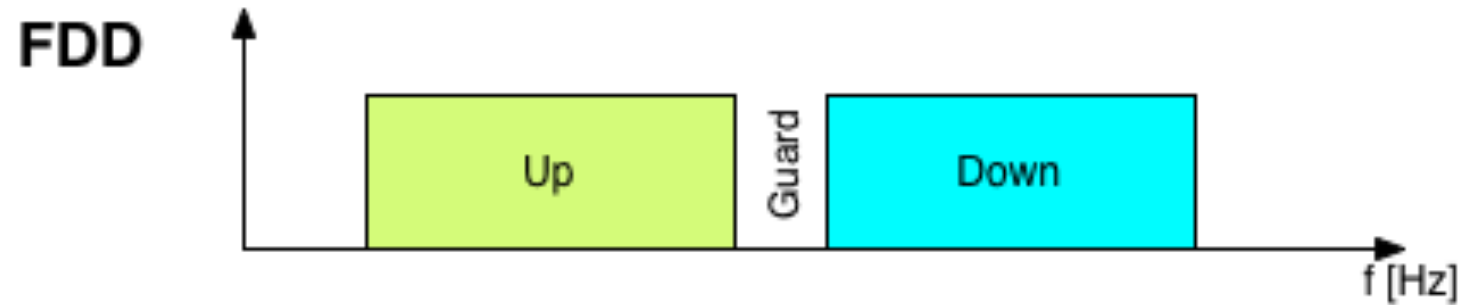

Point-to-point protocol (PPP)

- Direct connection between two nodes
 - Internet access
 - Home user to ISP
 - Telephone line
 - Cable TV

PPP

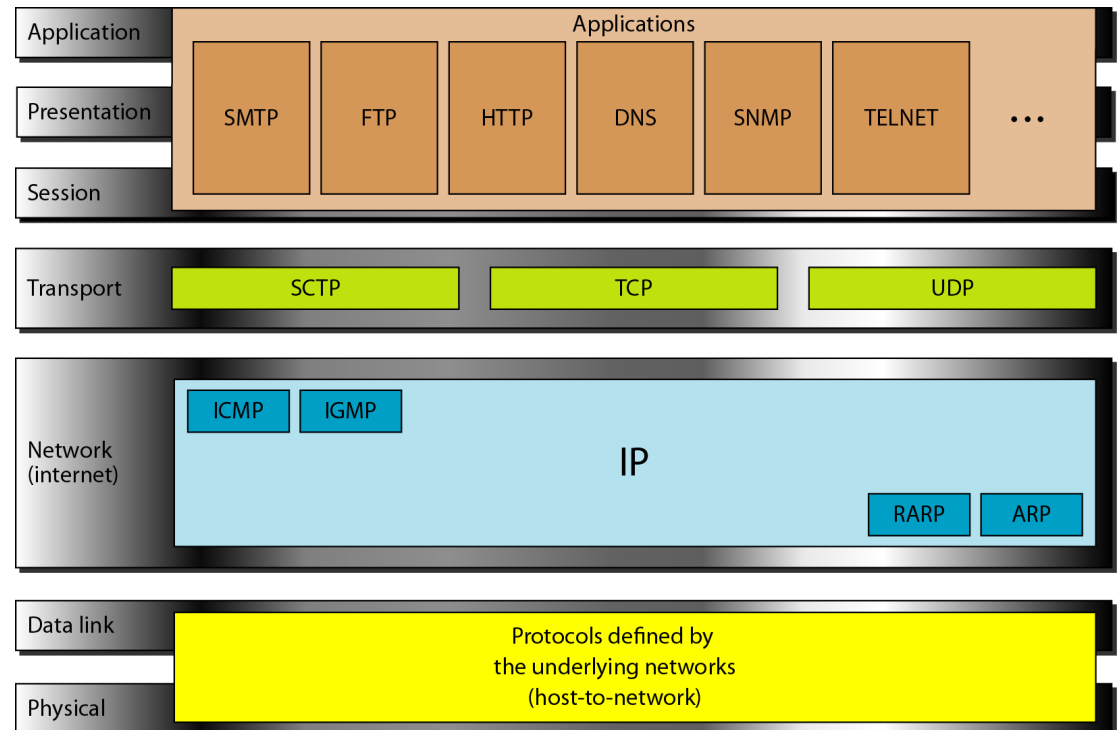
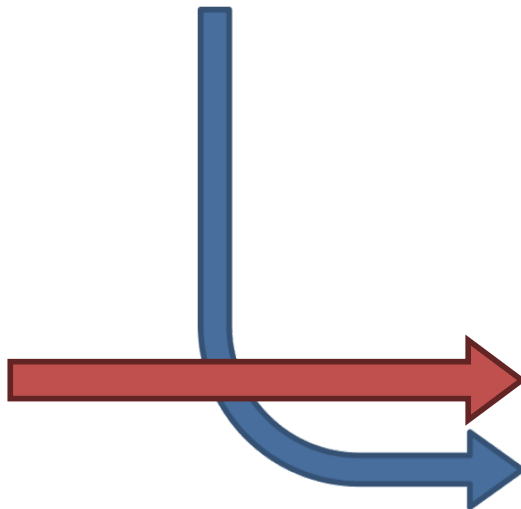

State transitions in PPP

- We need more protocols

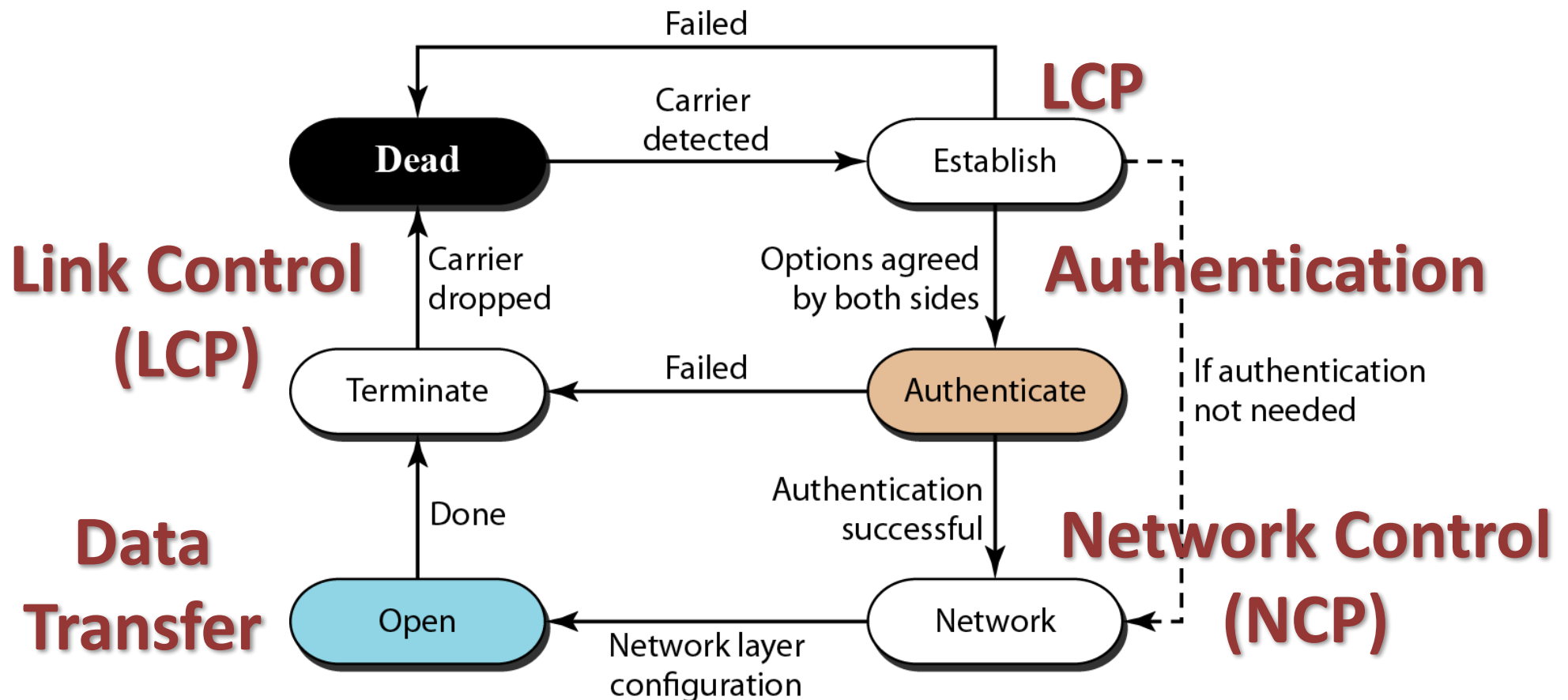

PPP frame format

- Support for several (sub)protocols
- Address & control not used
- Maximum payload 1500 bytes

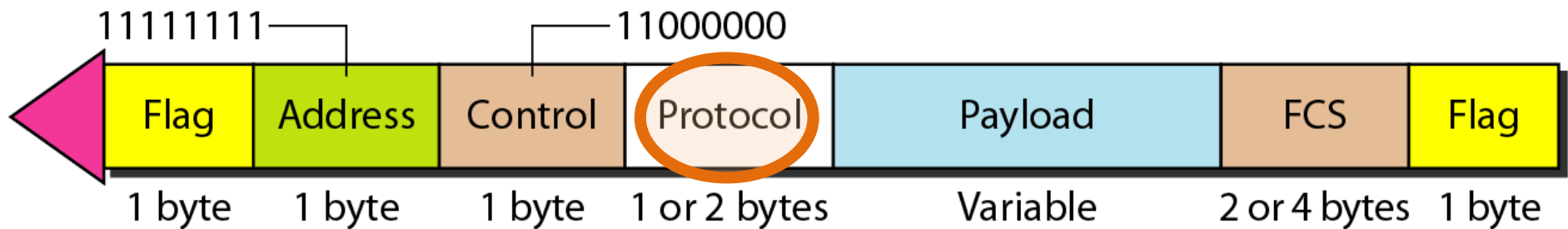

LCP: 0xC021
AP: 0xC023 and 0xC223
NCP: 0x8021 and
Data: 0x0021 and

LCP: Link Control Protocol
AP: Authentication Protocol
NCP: Network Control Protocol

Link control protocol (LCP)

- Establish
- Configure
- Terminate

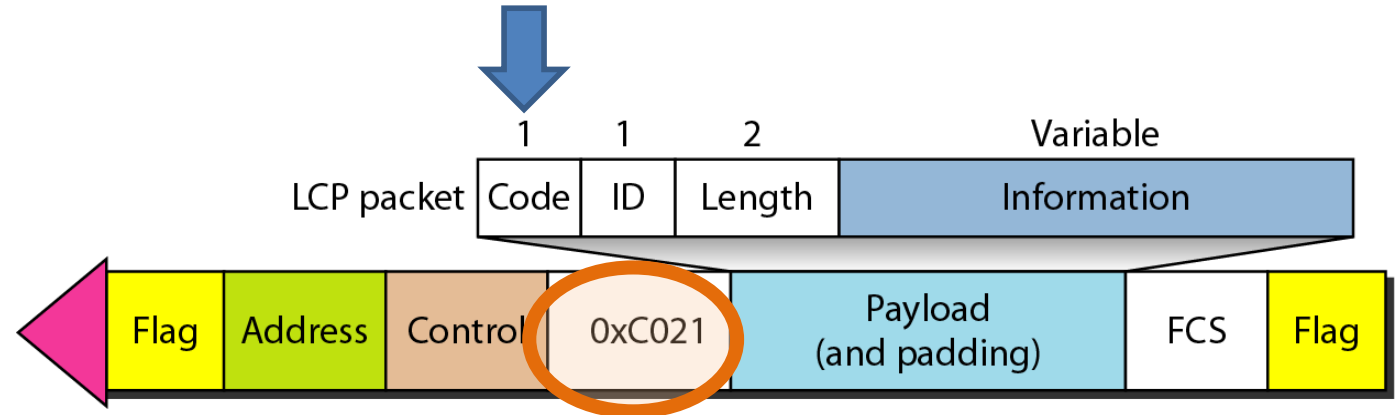

	Code	Packet Type	Description
Link Configuration	0x01	Configure-request	Contains the list of proposed options and their values
	0x02	Configure-ack	Accepts all options proposed
	0x03	Configure-nak	Announces that some options are not acceptable
	0x04	Configure-reject	Announces that some options are not recognized
Link Termination	0x05	Terminate-request	Request to shut down the line
	0x06	Terminate-ack	Accept the shutdown request
Monitoring and Debugging	0x07	Code-reject	Announces an unknown code
	0x08	Protocol-reject	Announces an unknown protocol
	0x09	Echo-request	A type of hello message to check if the other end is alive
	0x0A	Echo-reply	The response to the echo-request message
	0x0B	Discard-request	A request to discard the packet

Authentication protocols (AP)

- Password authentication (PAP)

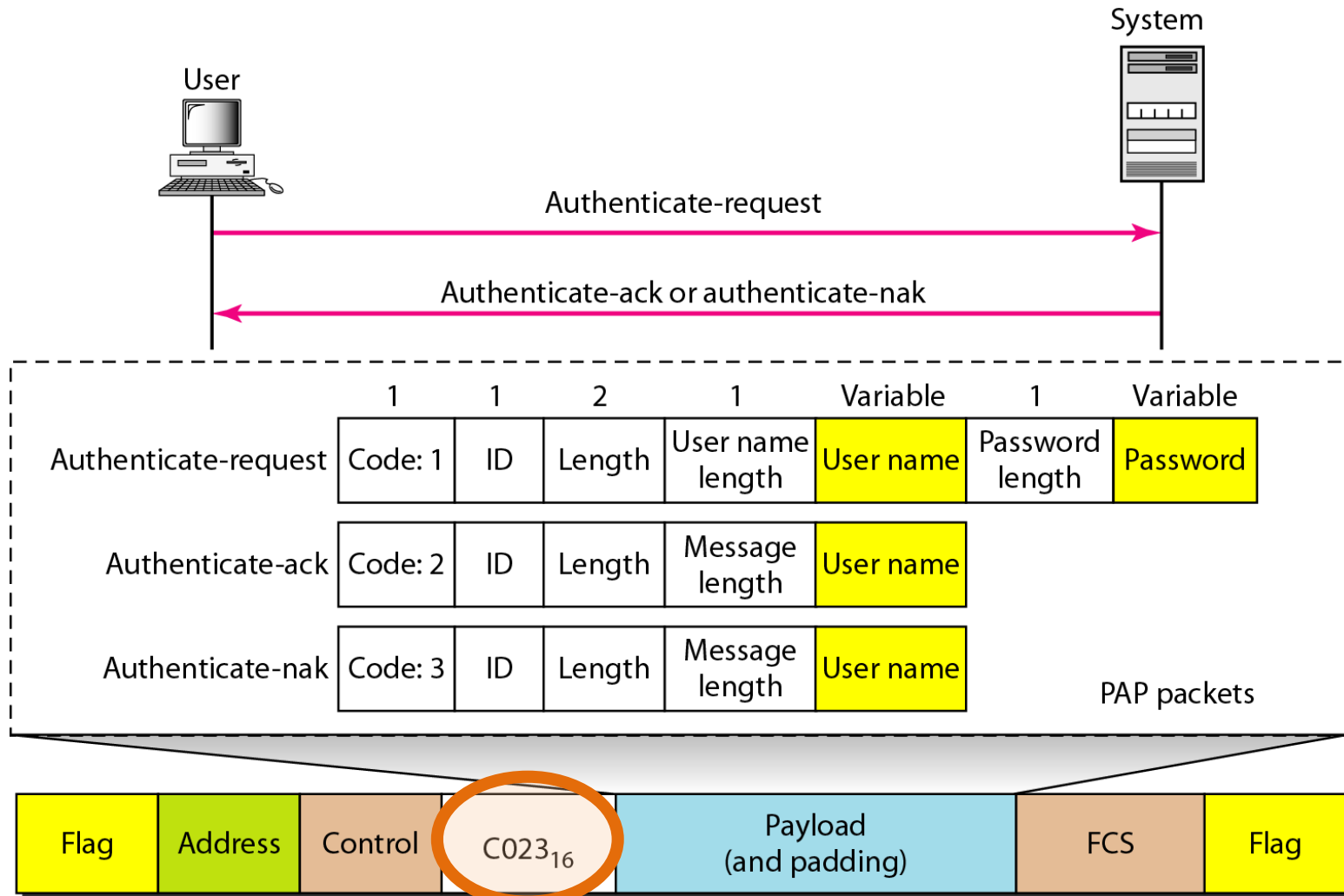

Authentication protocols (AP)

- Challenge handshake authentication (CHAP)

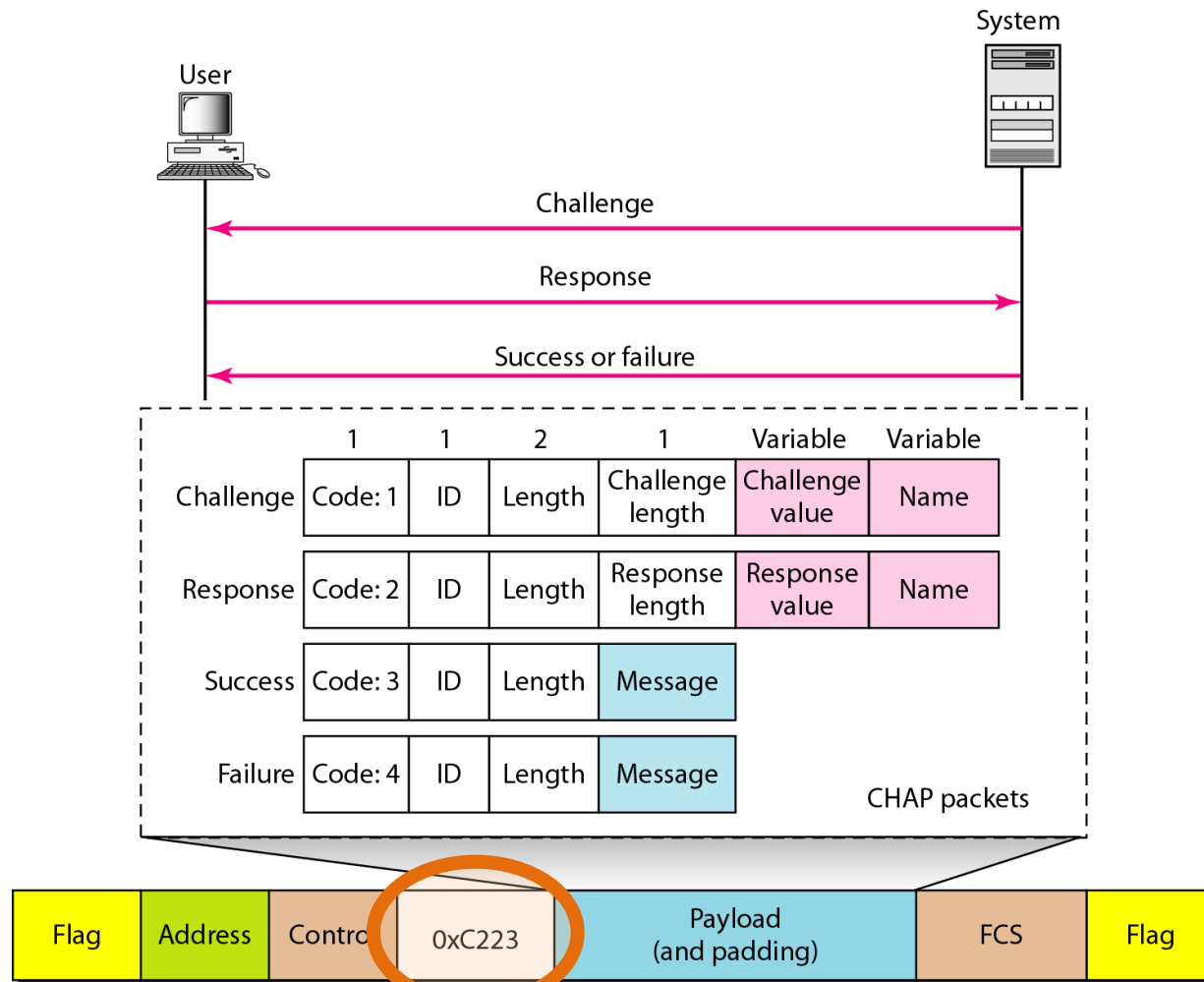

Network control protocols (NCP)

- Preparations for the network layer
 - IPCP for Internet

<i>Code</i>	<i>IPCP Packet</i>
0x01	Configure-request
0x02	Configure-ack
0x03	Configure-nak
0x04	Configure-reject
0x05	Terminate-request
0x06	Terminate-ack
0x07	Code-reject

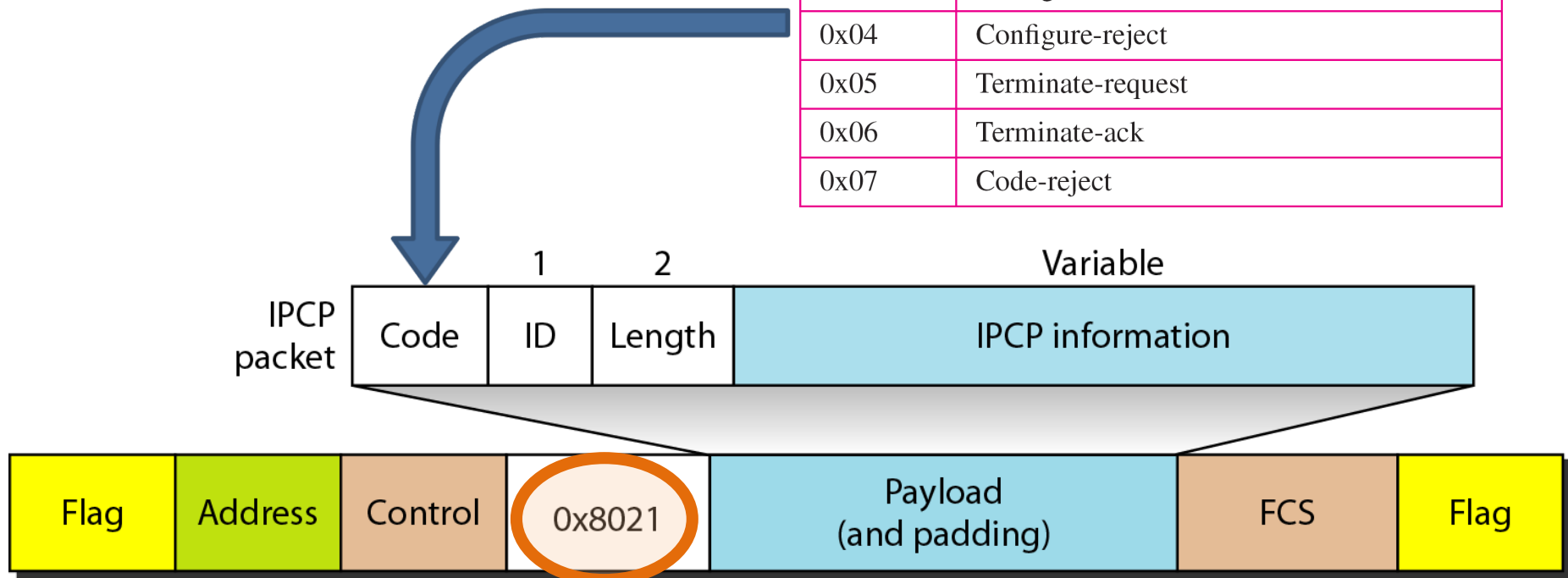

IP datagram encapsulation in PPP

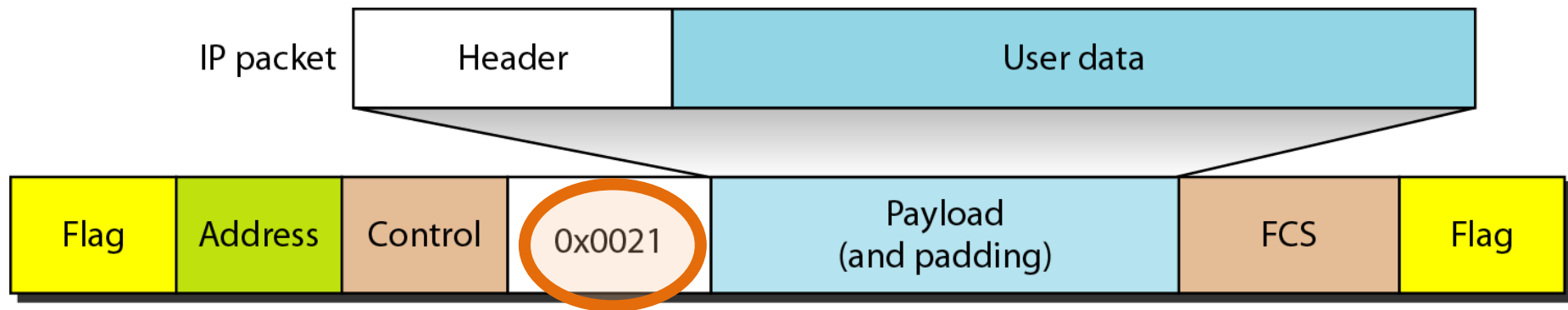

PPP session example

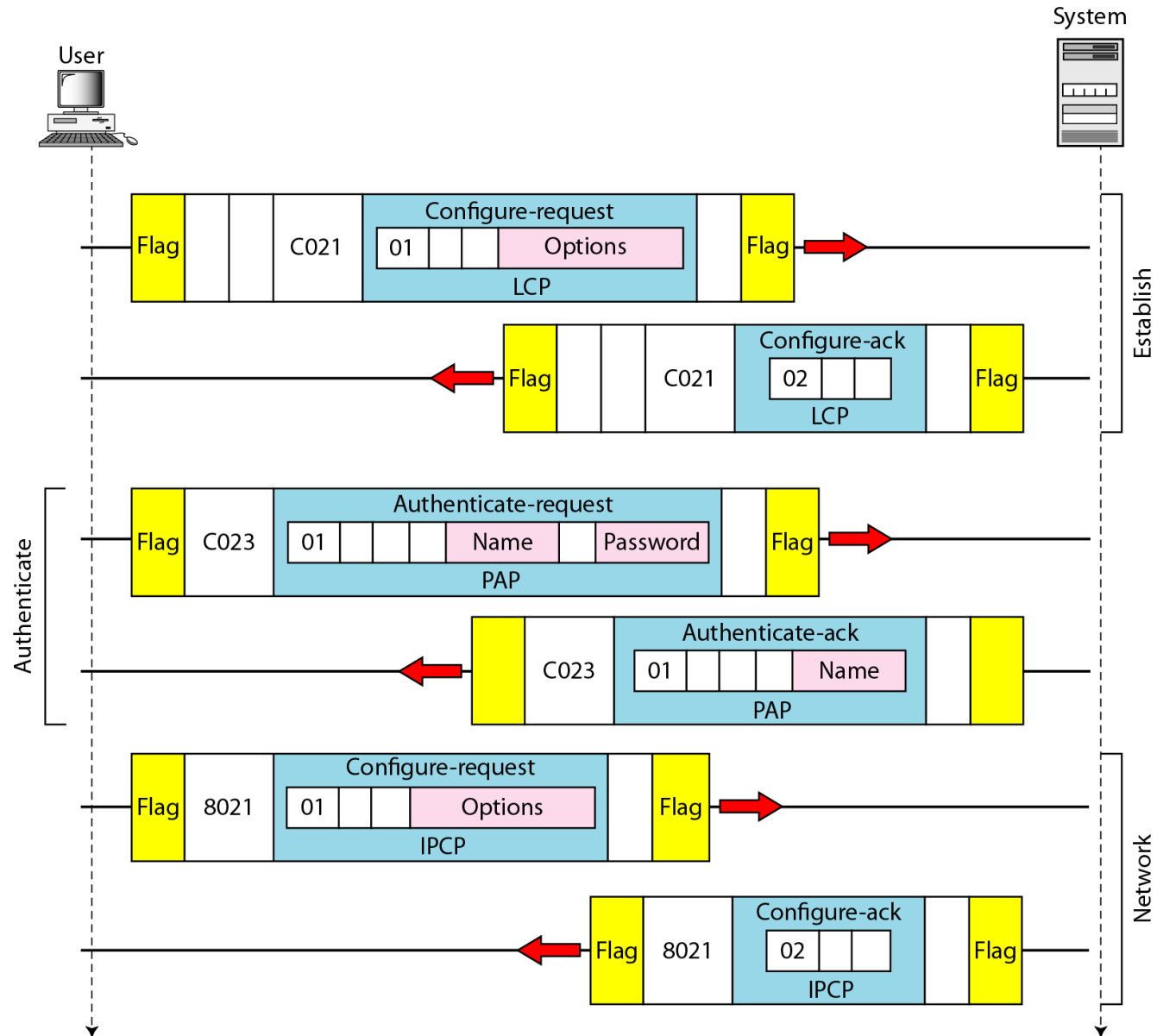

PPP session example (cont'd)

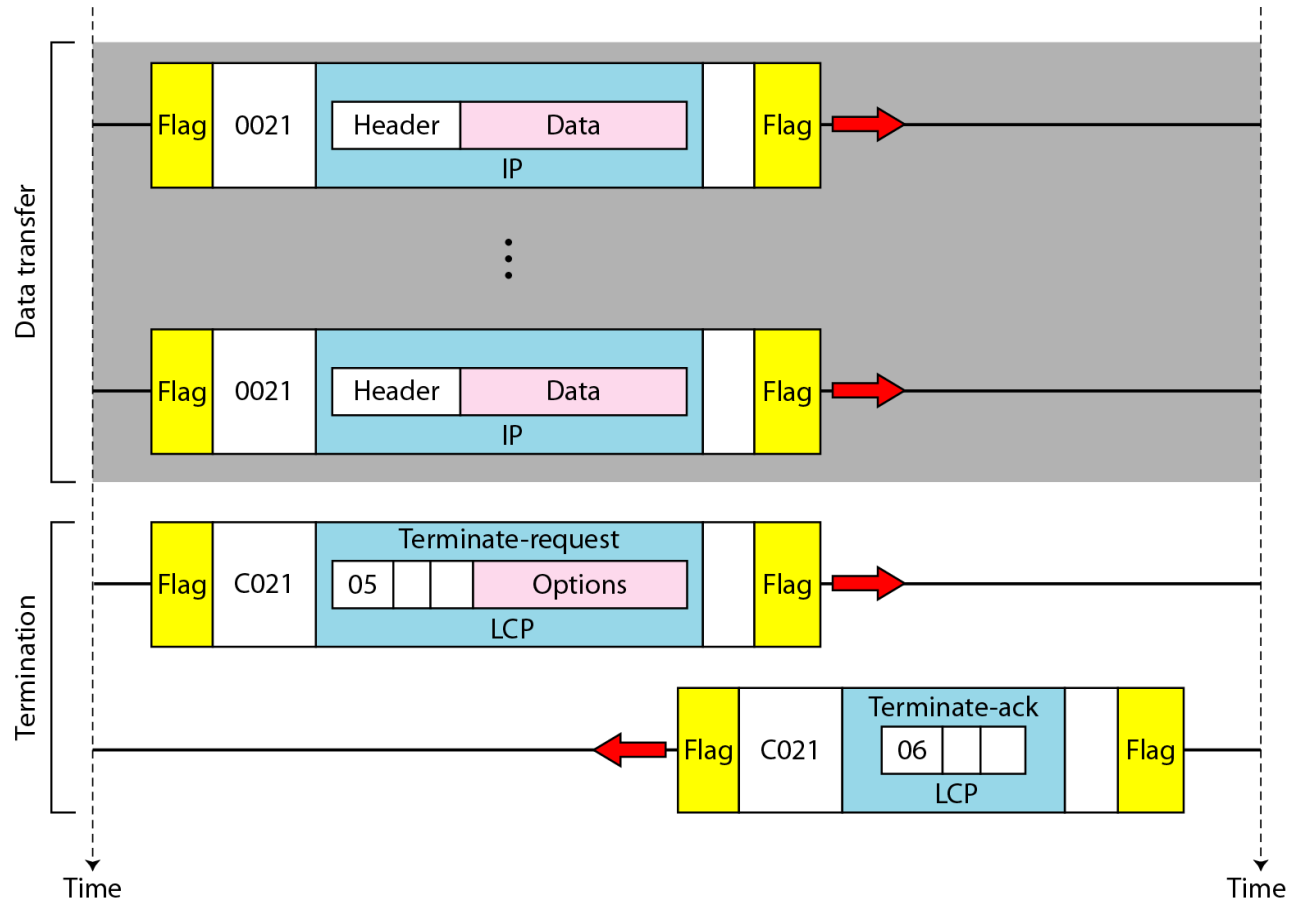

SONET/SDH

- Synchronous Optical Network (ANSI)
- Synchronous Digital Hierarchy (ITU-T)
- High speed capability of optical fiber
- Defines hierarchy of signal rates
 - Synchronous Transport Signal level 1 (STS-1) or Optical Carrier level 1 (OC-1) is 51.84Mbps
 - Carries one DS-3 or multiple (DS1 DS1C DS2) plus ITU-T rates (e.g., 2.048Mbps)
 - Multiple STS-1 combine into STS-N signal
 - ITU-T lowest rate is 155.52Mbps (STM-1)

Digital hierarchy on optical links

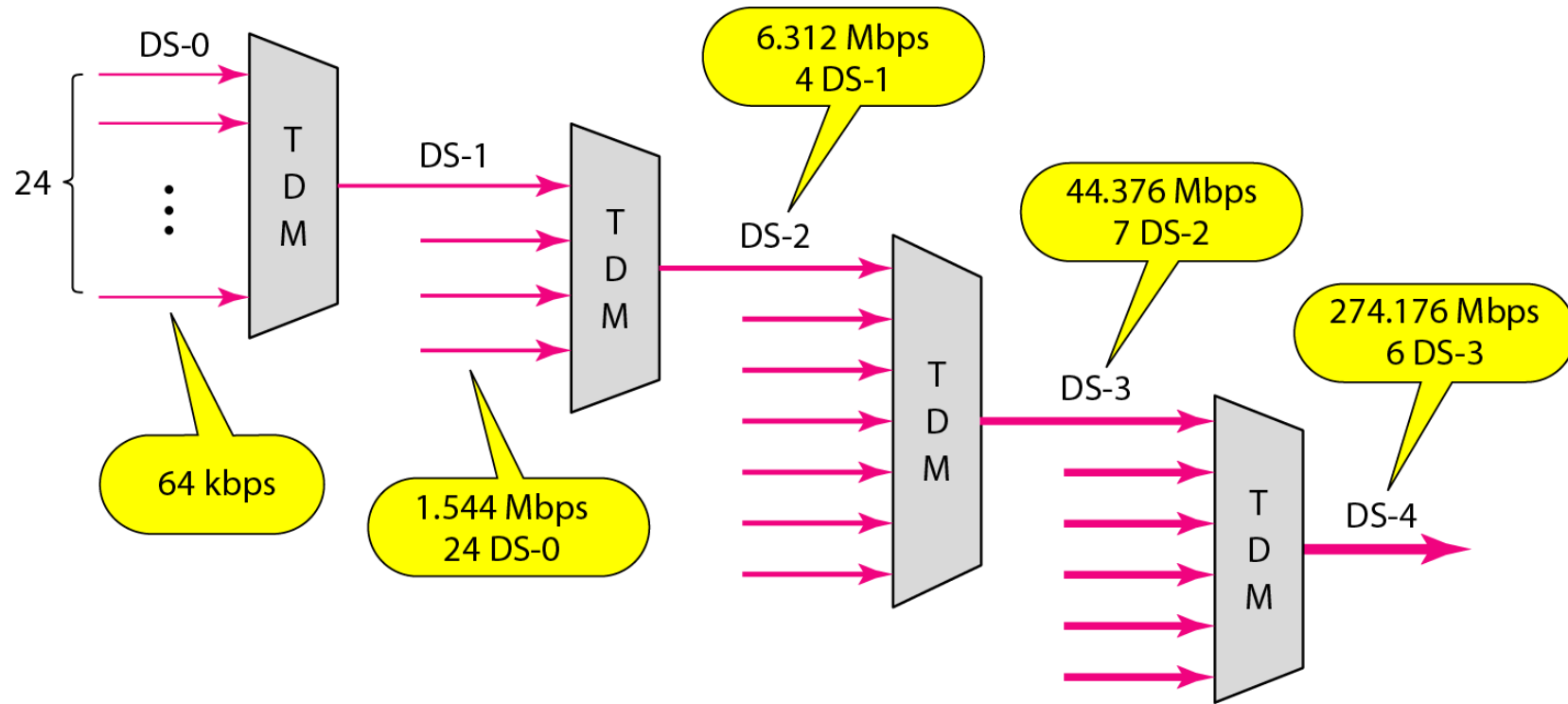

Table 8.4

SONET/SDH Signal Hierarchy

SONET Designation	ITU-T Designation	Data Rate	Payload Rate (Mbps)
STS-1/OC-1		51.84 Mbps	50.112 Mbps
STS-3/OC-3	STM-1	155.52 Mbps	150.336 Mbps
STS-12/OC-12	STM-4	622.08 Mbps	601.344 Mbps
STS-48/OC-48	STM-16	2.48832 Gbps	2.405376 Gbps
STS-192/OC-192	STM-64	9.95328 Gbps	9.621504 Gbps
STS-768	STM-256	39.81312 Gbps	38.486016 Gbps
STS-3072		159.25248 Gbps	153.944064 Gbps

SONET frames

- Proportional to data rates

<i>STS</i>	<i>OC</i>	<i>Rate (Mbps)</i>	<i>STM</i>
STS-1	OC-1	51.840	
STS-3	OC-3	155.520	STM-1
STS-9	OC-9	466.560	STM-3
STS-12	OC-12	622.080	STM-4
STS-18	OC-18	933.120	STM-6
STS-24	OC-24	1244.160	STM-8
STS-36	OC-36	1866.230	STM-12
STS-48	OC-48	2488.320	STM-16
STS-96	OC-96	4976.640	STM-32
STS-192	OC-192	9953.280	STM-64

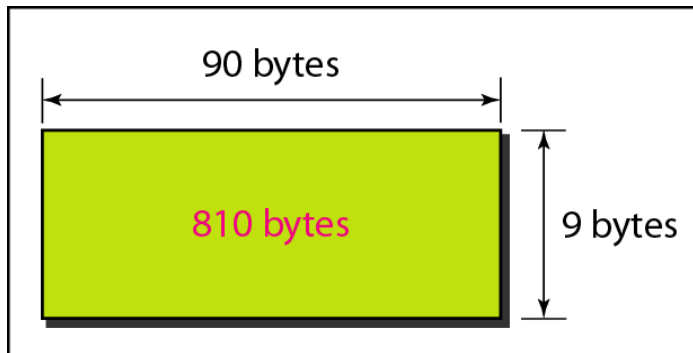

a. STS-1 frame

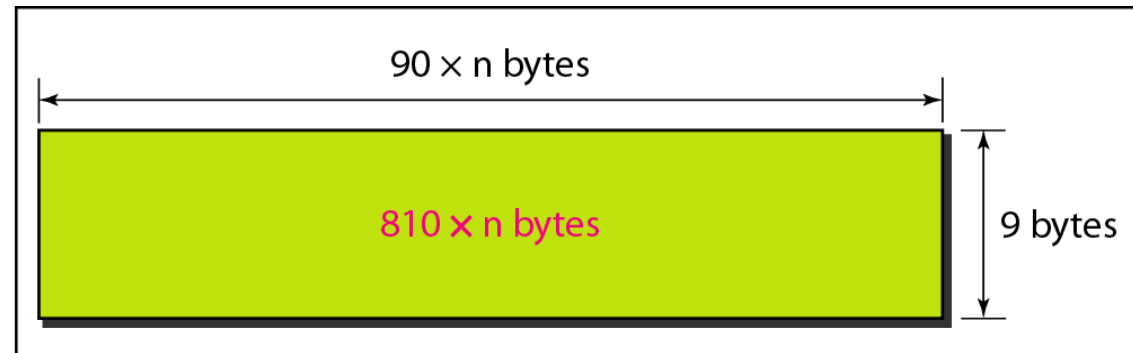

b. STS-n frame

SONET frames in transmission

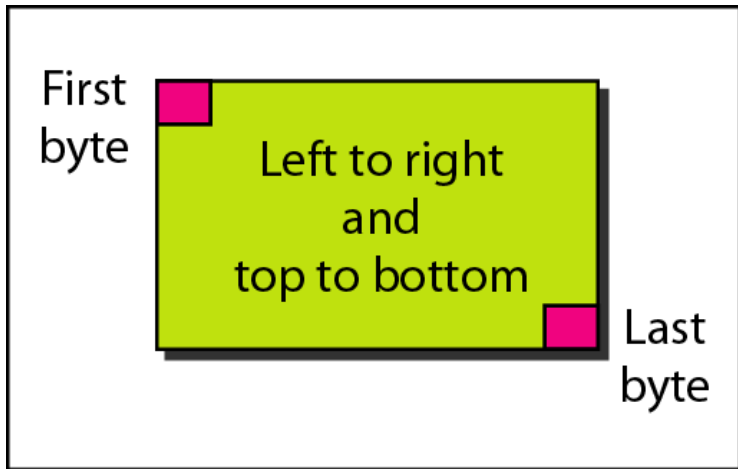

a. Byte transmission

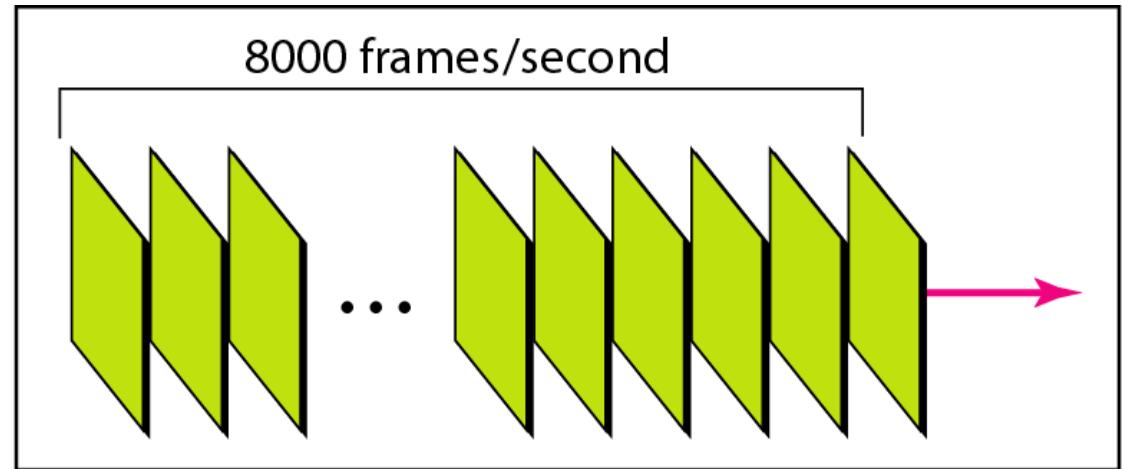

b. Frame transmission

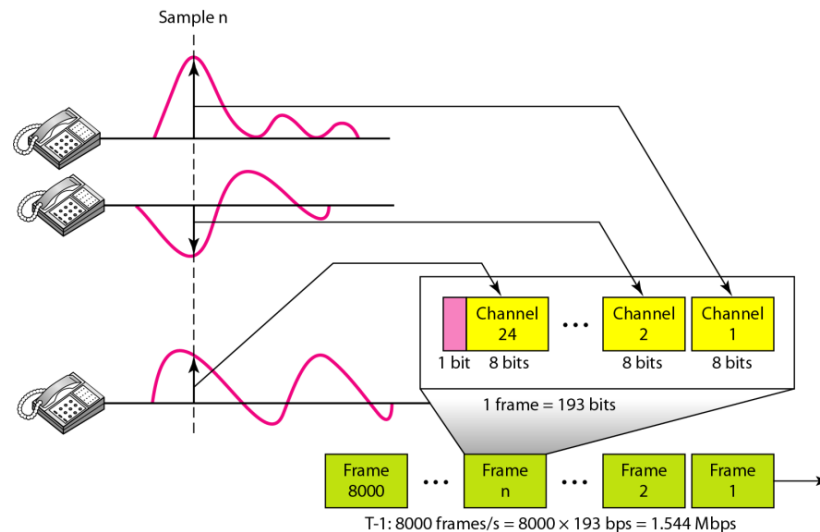

Network architecture

- Devices and connections

ADM: Add/drop multiplexer

STS MUX: Synchronous transport signal multiplexer

STS DEMUX: Synchronous transport signal demultiplexer

R: Regenerator

T: Terminal

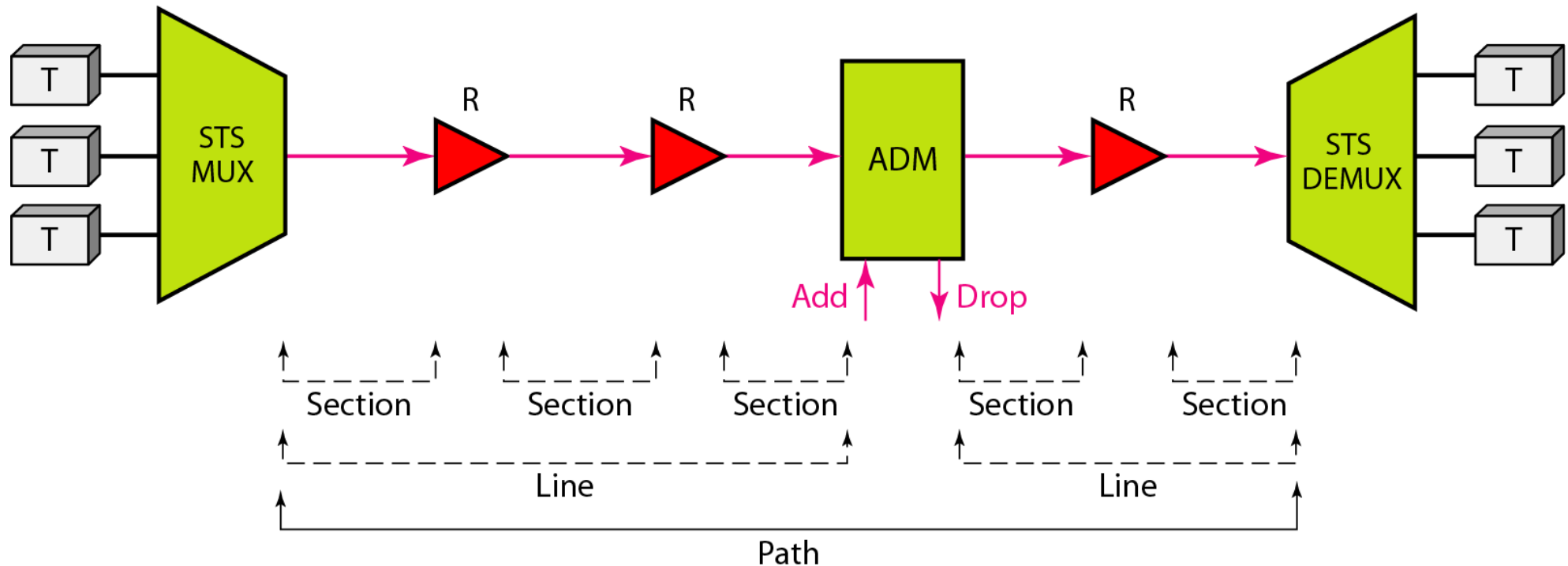

Network architecture

- Devices and layers

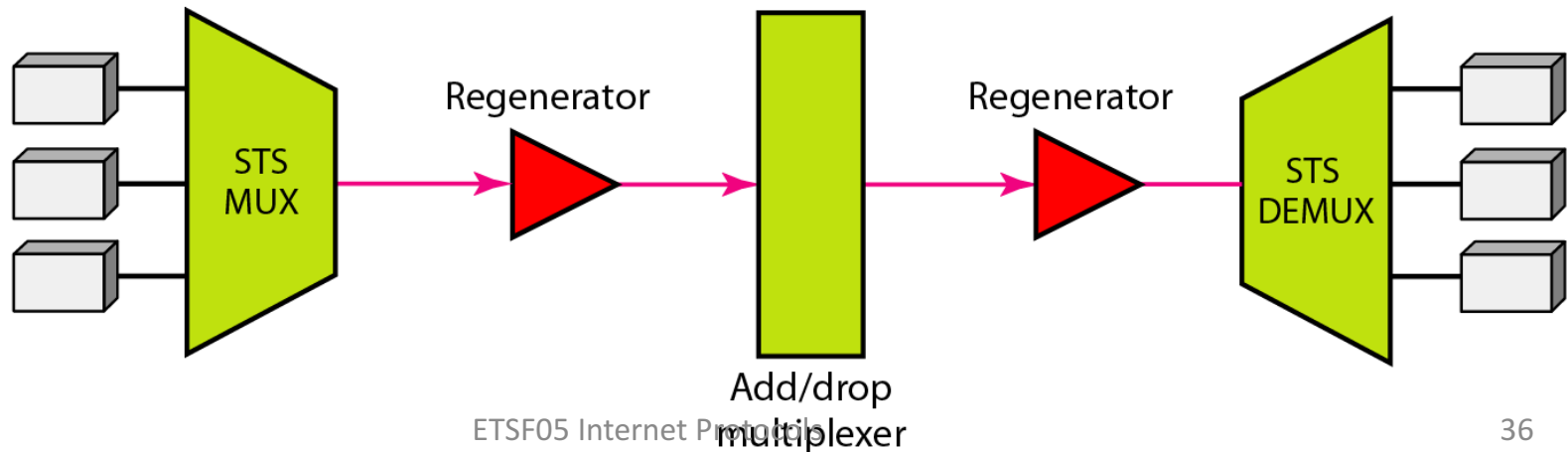
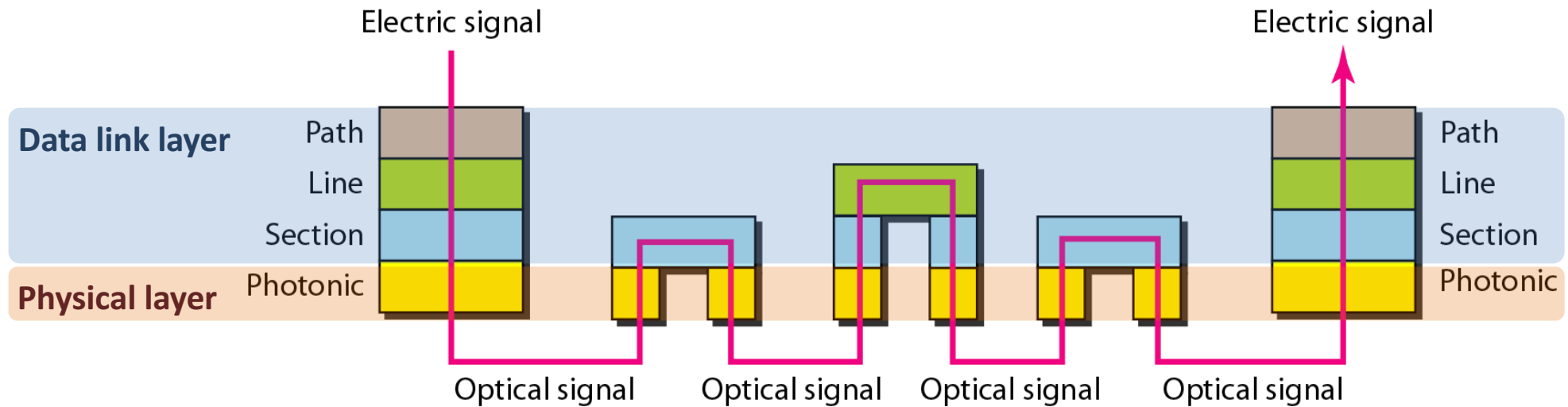

SONET add/drop multiplexer

- Replaces a signal with another one
- Operates at line layer
- Similar to a switch

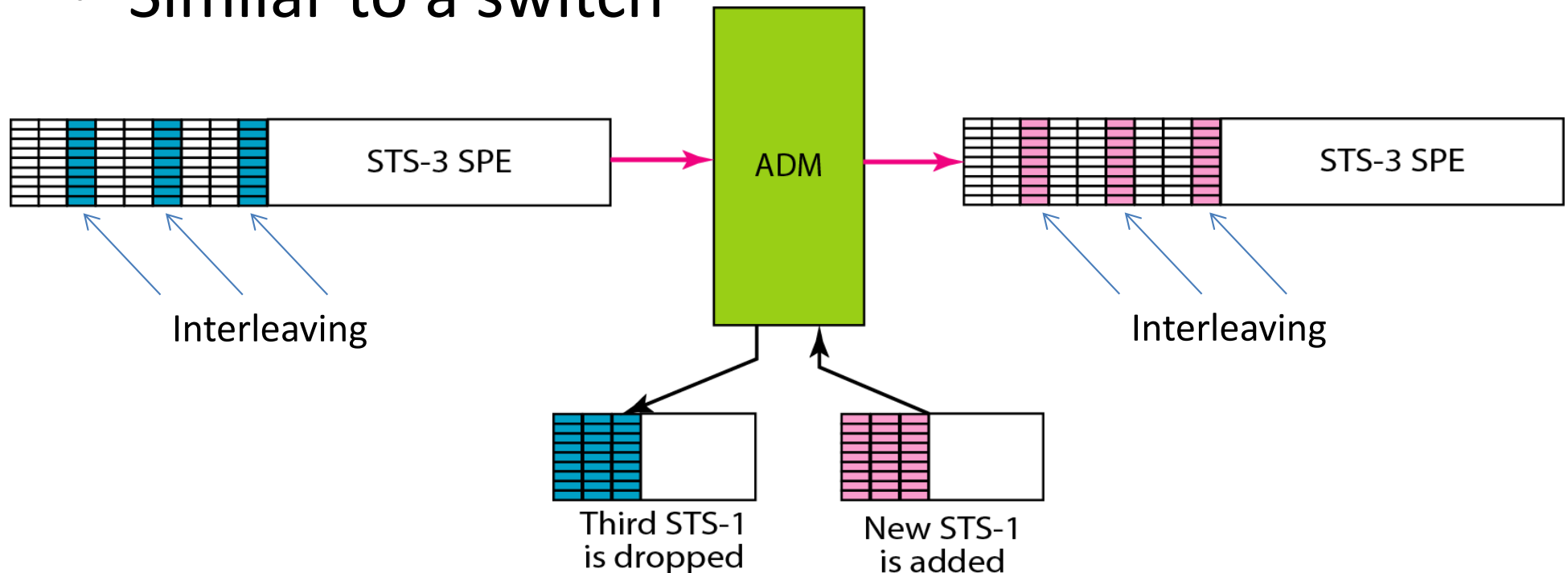

Multiplexing and byte interleaving

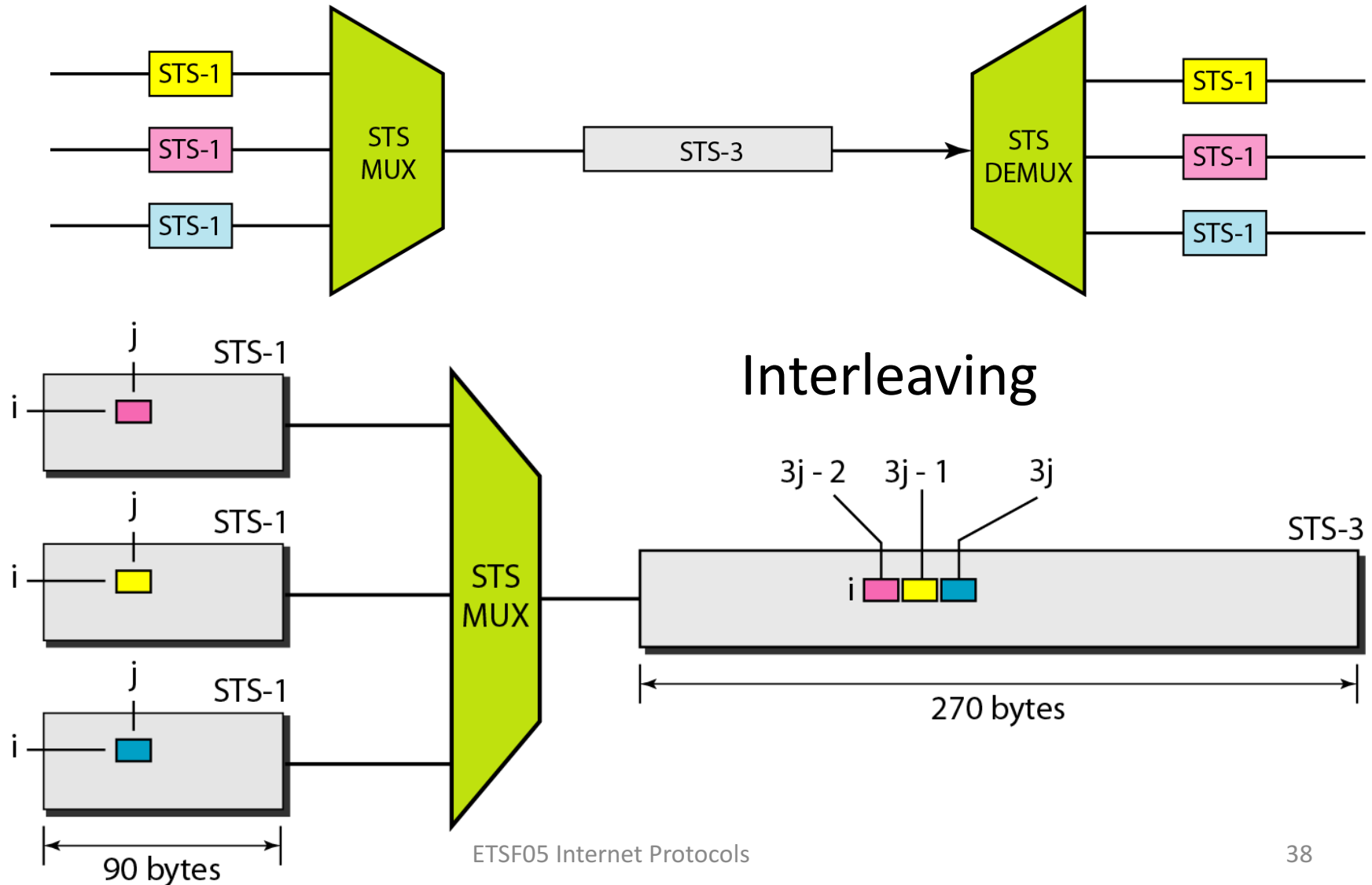

Automatic protection switching

- Failure protection through line redundancy

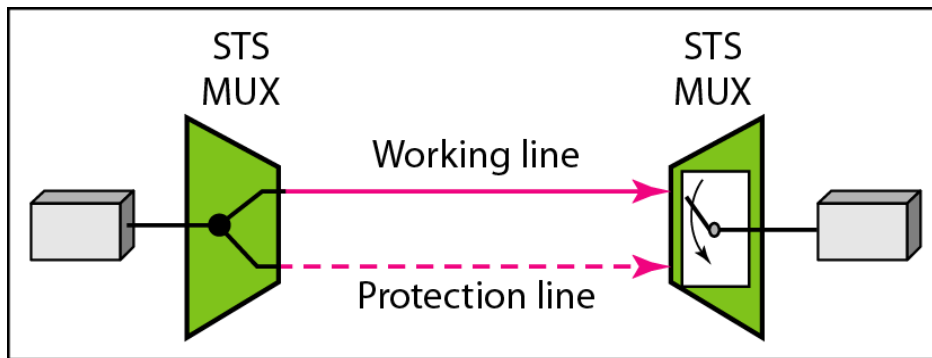

a. One-plus-one APS

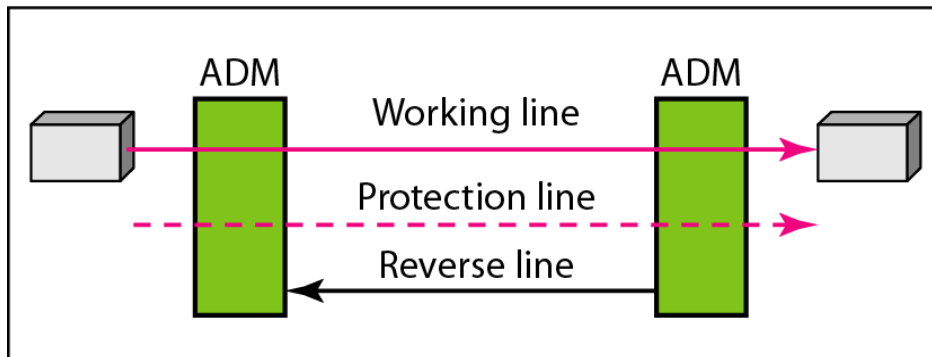

b. One-to-one APS

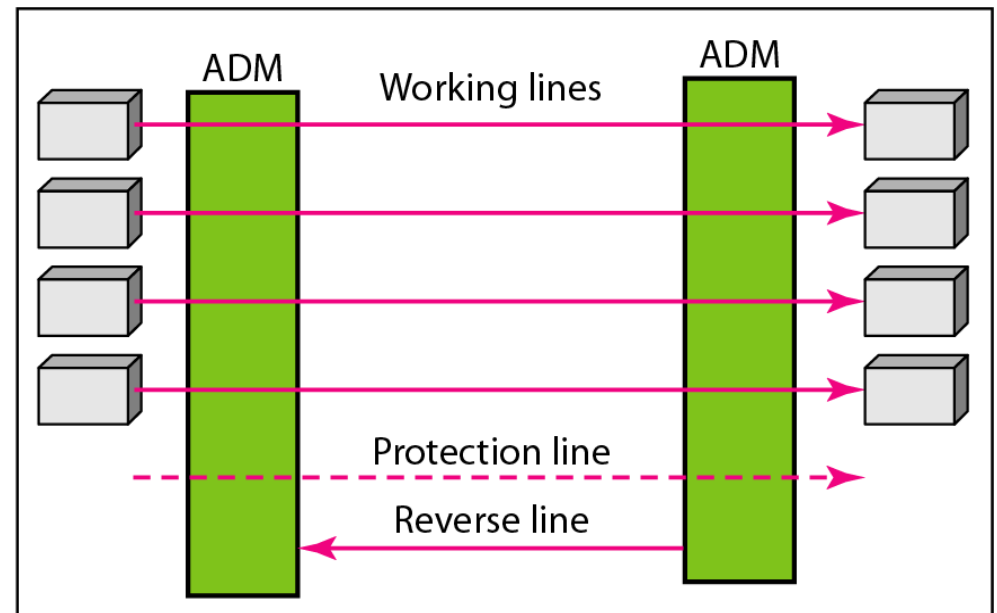

c. One-to-many APS

Ring SONET topology

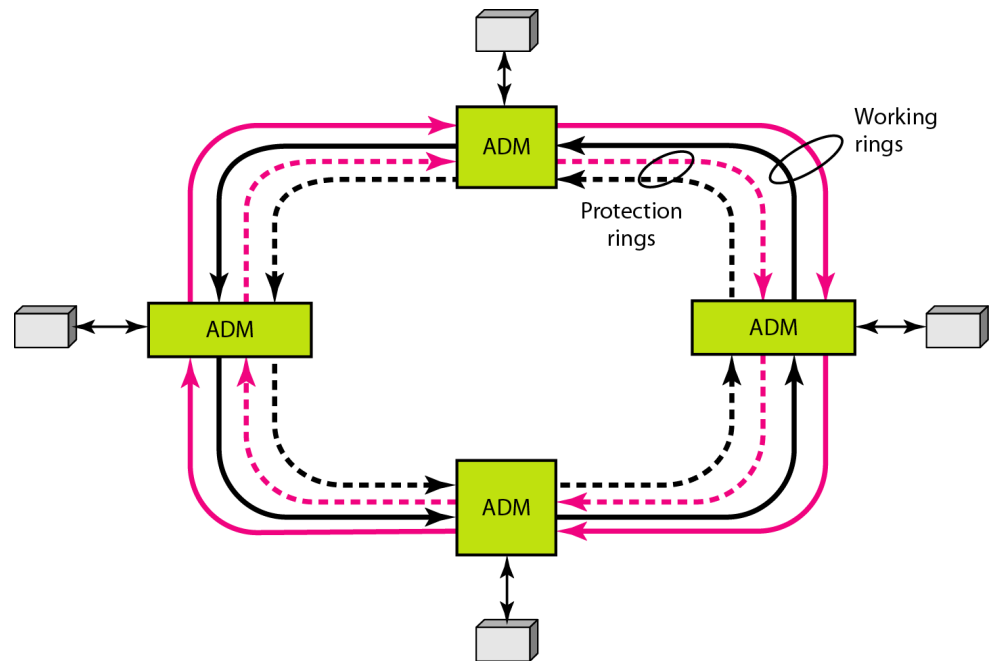
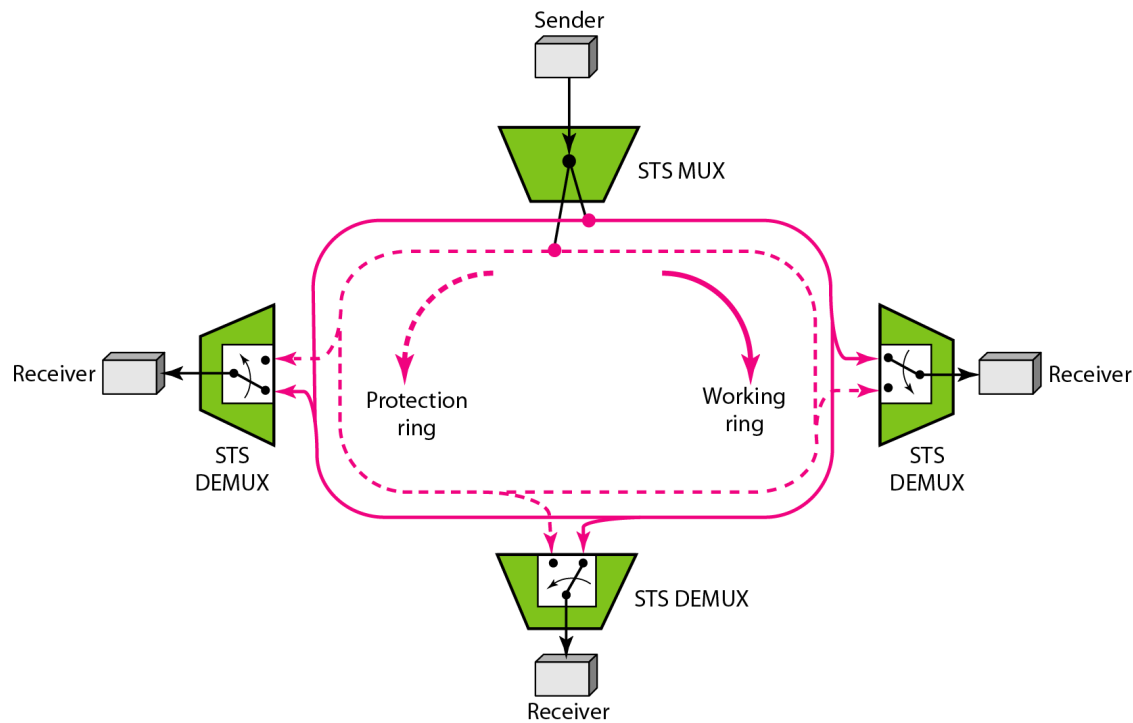

Mesh SONET topology

- Better scalability
 - Multiplexing/demultiplexing at switches

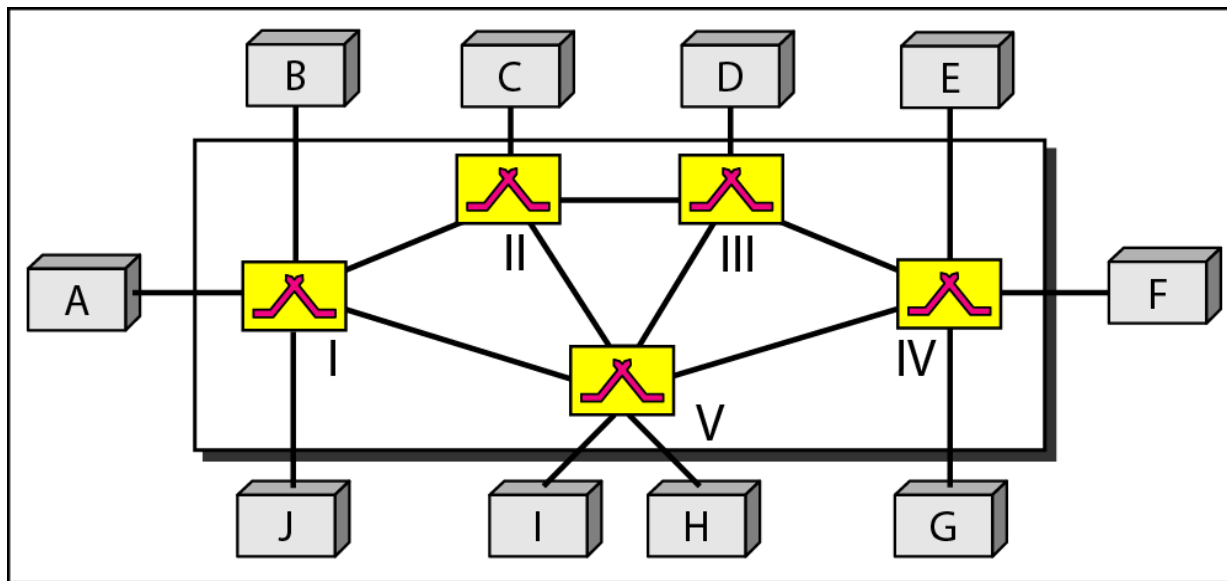

a. SONET mesh network

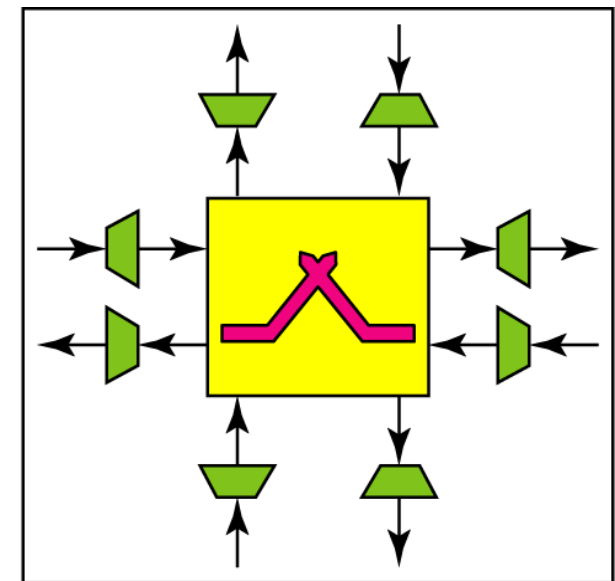

b. Cross-connect switch

Ethernet

- IEEE 802.3
- Original: 10BASE5
 - 1983
 - 10Mbps, Baseband, 500 meters
 - Coax as shared resource (collision domain)

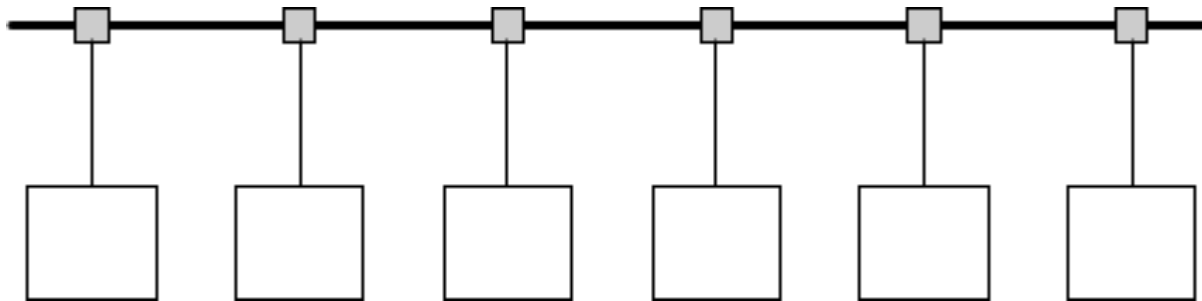

Ethernet evolution (selection)

Fast Ethernet (10 or 100 Mbps)				
10BASE-T	802.3i	1990	TP, cat3-	Start network RJ45 (8P8U)
10BASE-F	802.3j	1993	Fiber (MM)	Star network
100BASE-Tx	802.3u	1995	TP, cat3-	2 pairs, one each direction MLT-3
100BASE-Fx	802.3u	1995	Fiber (MM)	2 fibers

Gigabit Ethernet (1000 Mbps)				
1000BASE-X	802.3z	1998	Fiber (MM/SM)	
1000BASE-T	802.3ab	1999	TP, cat5-	PAM-5

Ethernet evolution (selection)

10 Gigabit Ethernet (10 Gbps)

10GBASE-SR, etc	802.3ae	2002	Fiber (SM/MM)	
10GBASE-T		2006	TP, cat6-	PAM
10GBASE-PR			Fiber	PON

100 Gigabit Ethernet (40 or 100 Gbps)

40GBASE-LR4 100GBASE-LR4	802.3ba	2011	Fiber (SM)	10km WDM
40GBASE-T	802.3bq	2016	TP, cat8-	16-PAM
100G EPON	802.3ca	2019 (TBD)	Fiber	WDM-PON (?)

Fiber topologies

- P2P
- P2MP (PON)
- WDM

Fiber topologies

- P2P (e.g. Ethernet)

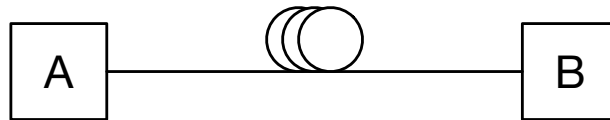

- P2MP (e.g. EPON, GPON)

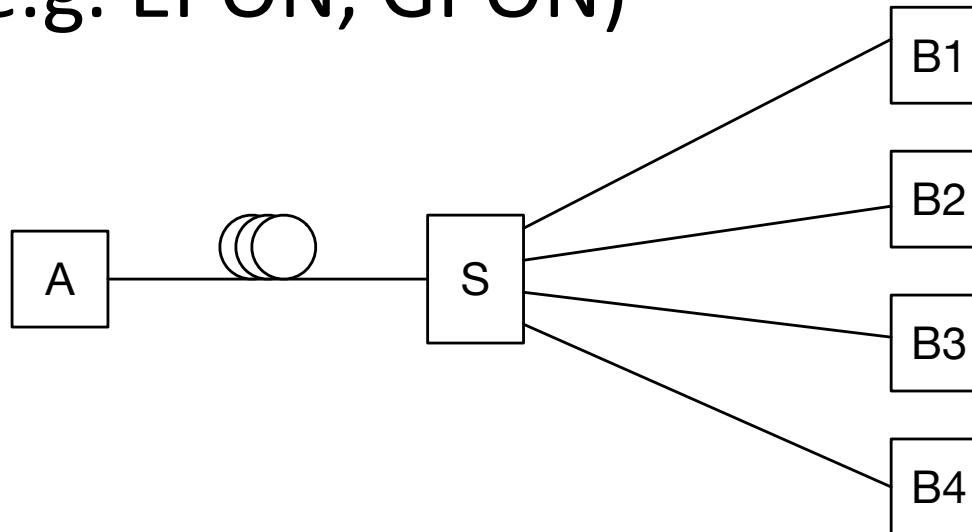

Fiber topologies

- WDM(e.g. 100GBASE-LR4, WDM-PON)

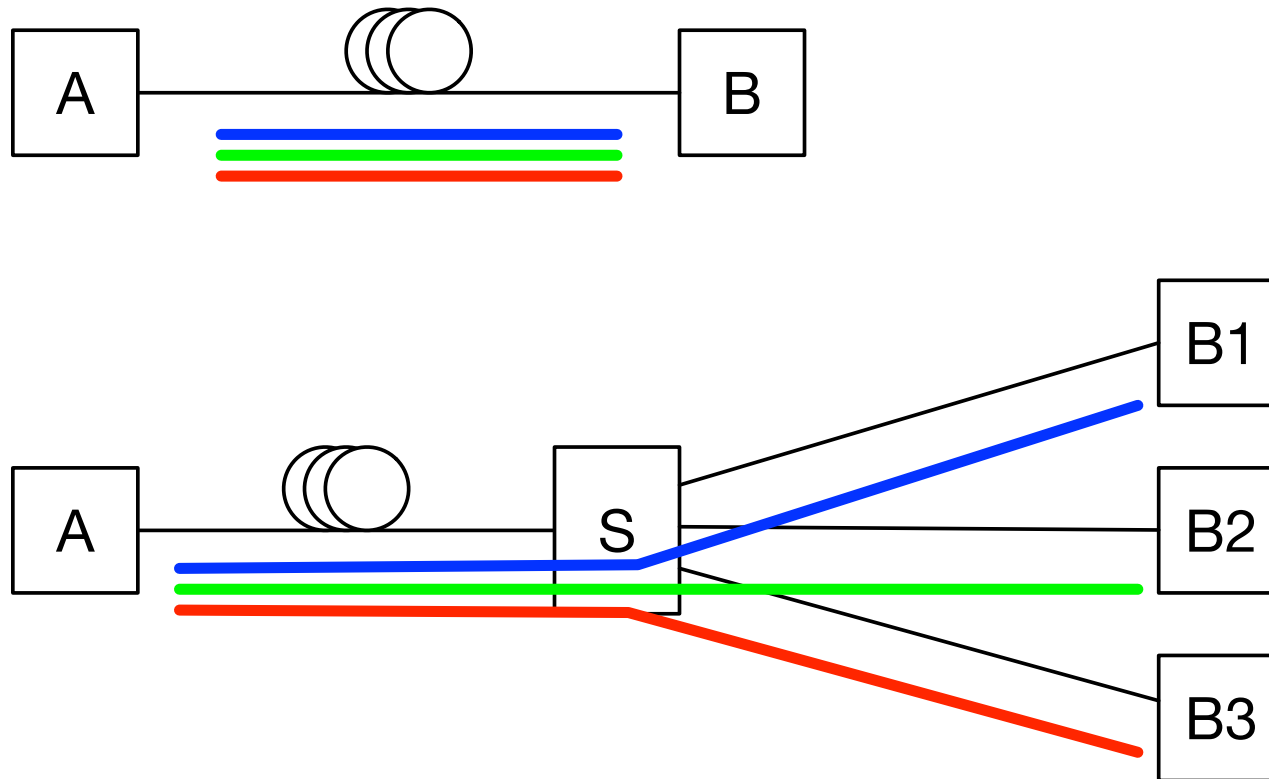

Asymmetrical Digital Subscriber Line (ADSL)

- Link between subscriber (home) and network
- Uses existing twisted pair cable
- Is Asymmetric - higher downstream than upstream
- Uses Frequency Division Multiplexing
 - Reserve lowest 25kHz for voice (POTS)
 - Uses echo cancellation or FDM to give two bands

Discrete Multitone (DMT)

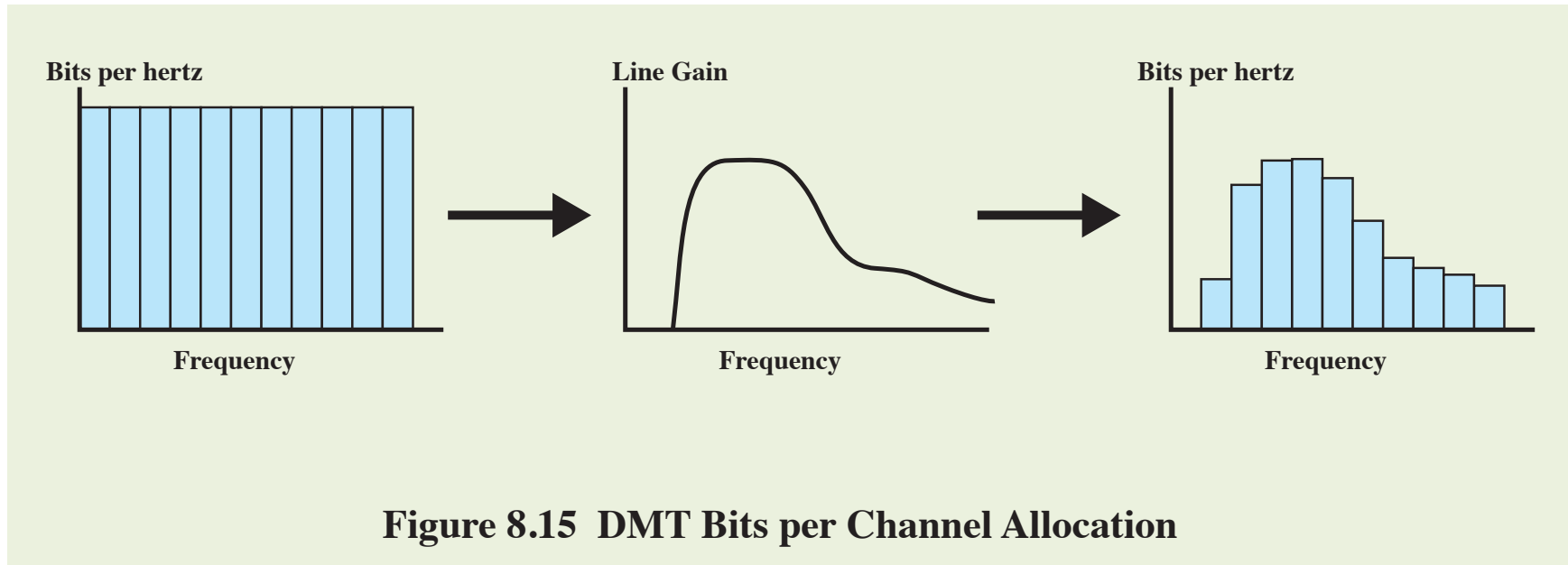

- Multiple carrier signals at different frequencies
- Divide into 4kHz sub-channels
- Test and use subchannels with better SNR

Discrete Multitone (DMT)

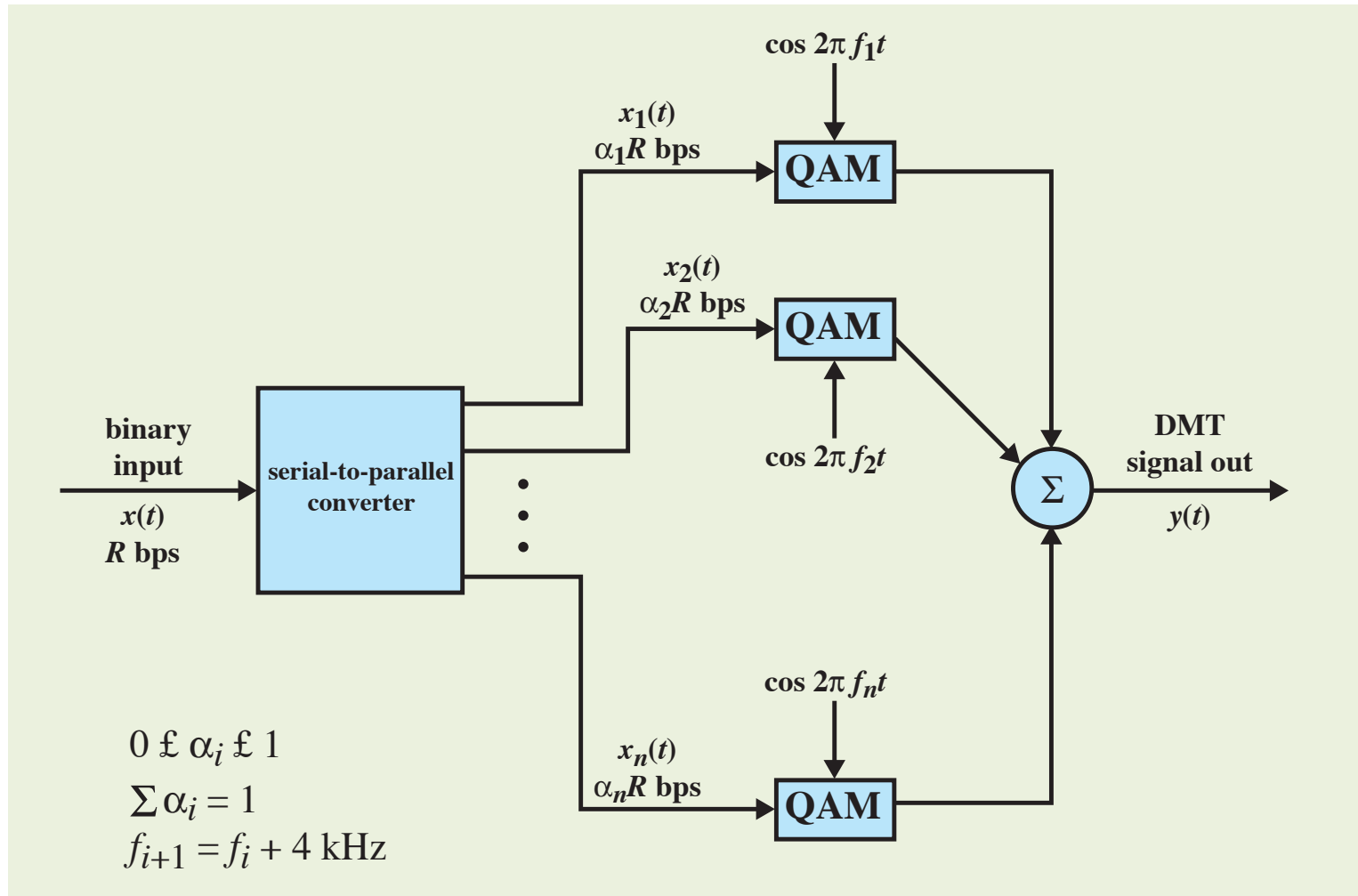

QAM=Quadrature Amplitude Modulation

Discrete Multitone (DMT)

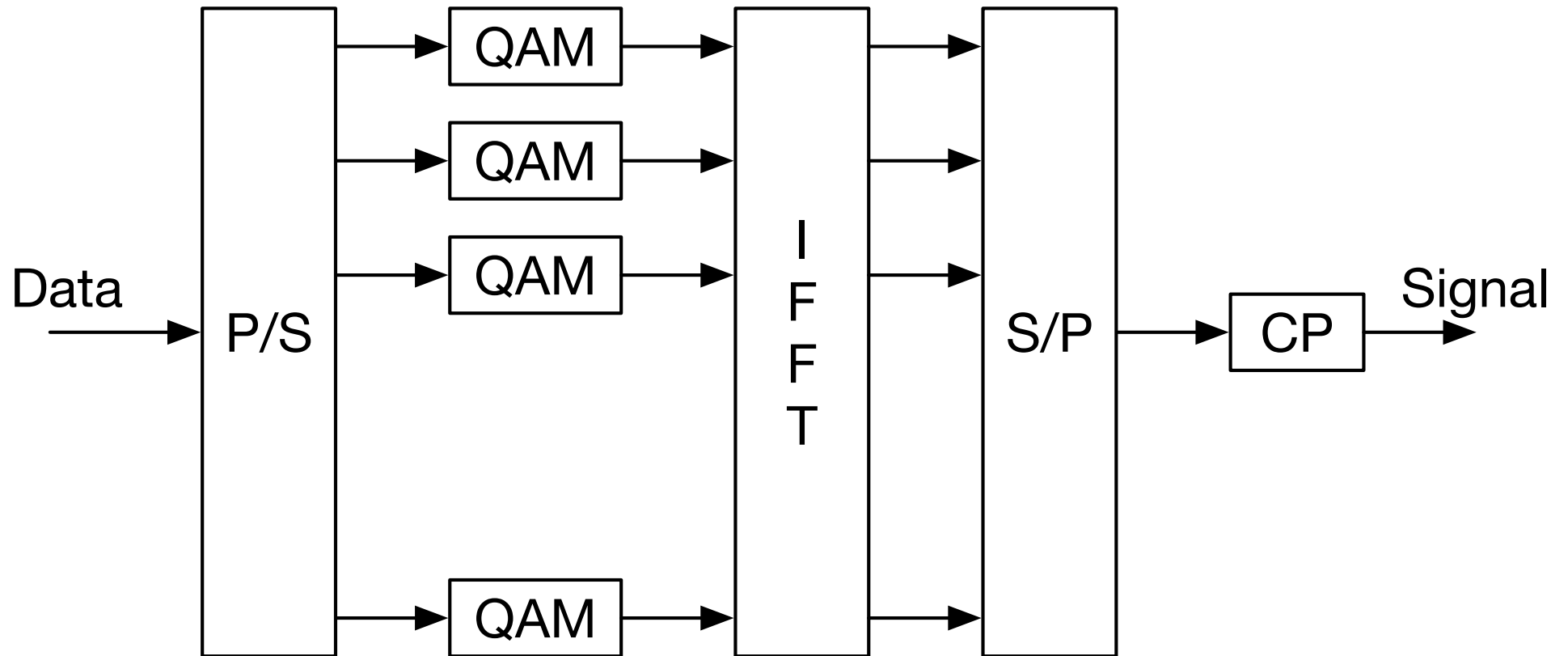

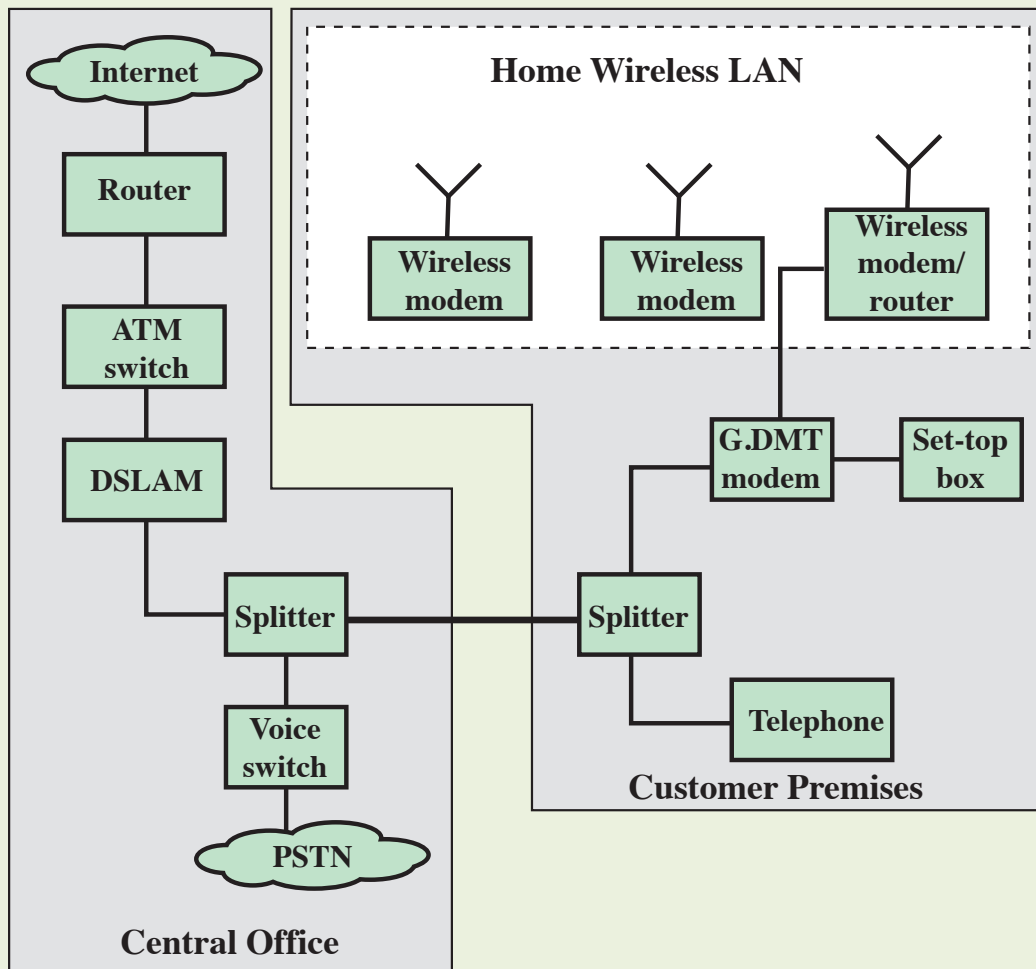

ATM = Asynchronous Transfer Mode
 DSLAM = Digital Subscriber Line Access Multiplexer
 PSTN = Public Switched Telephone Network
 G.DMT = G.992.1 Discrete Multitone

Figure 8.17 DSL Broadband Access

xDSL access

	ADSL2+	VDSL2	G.fast
ITU-T	G.992.5	G.993.2	G.9700 G.9701 (2014)
Frequency band	25 k – 2.2 MHz	25 k – 17 MHz (– 8,12,17,30)	30 M – 100 MHz (30 M – 200 MHz)
Data rate	U/D: 2/24 Mbps	~100 Mbps	~500 Mbps (~1 Gbps)
Distance	0 – 7 km	0 – 1.5 km	0 – 400 m

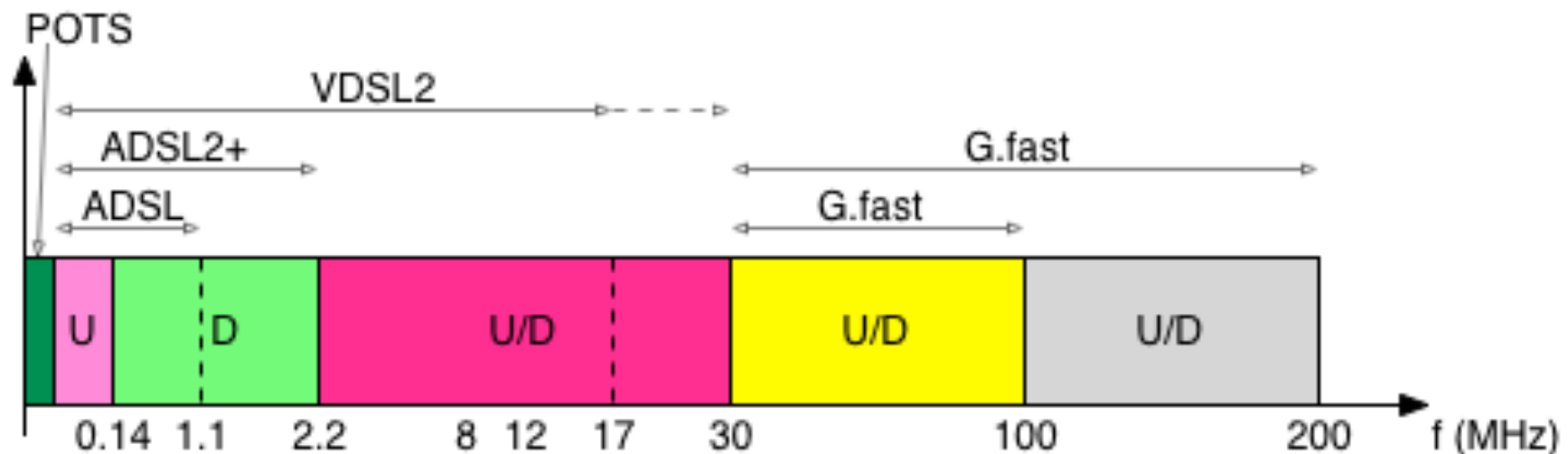

WLAN and WiFi

- IEEE 802.11
- "Trådlöst Ethernet"
- Tre konfigurationsprinciper

System med en accesspunkt

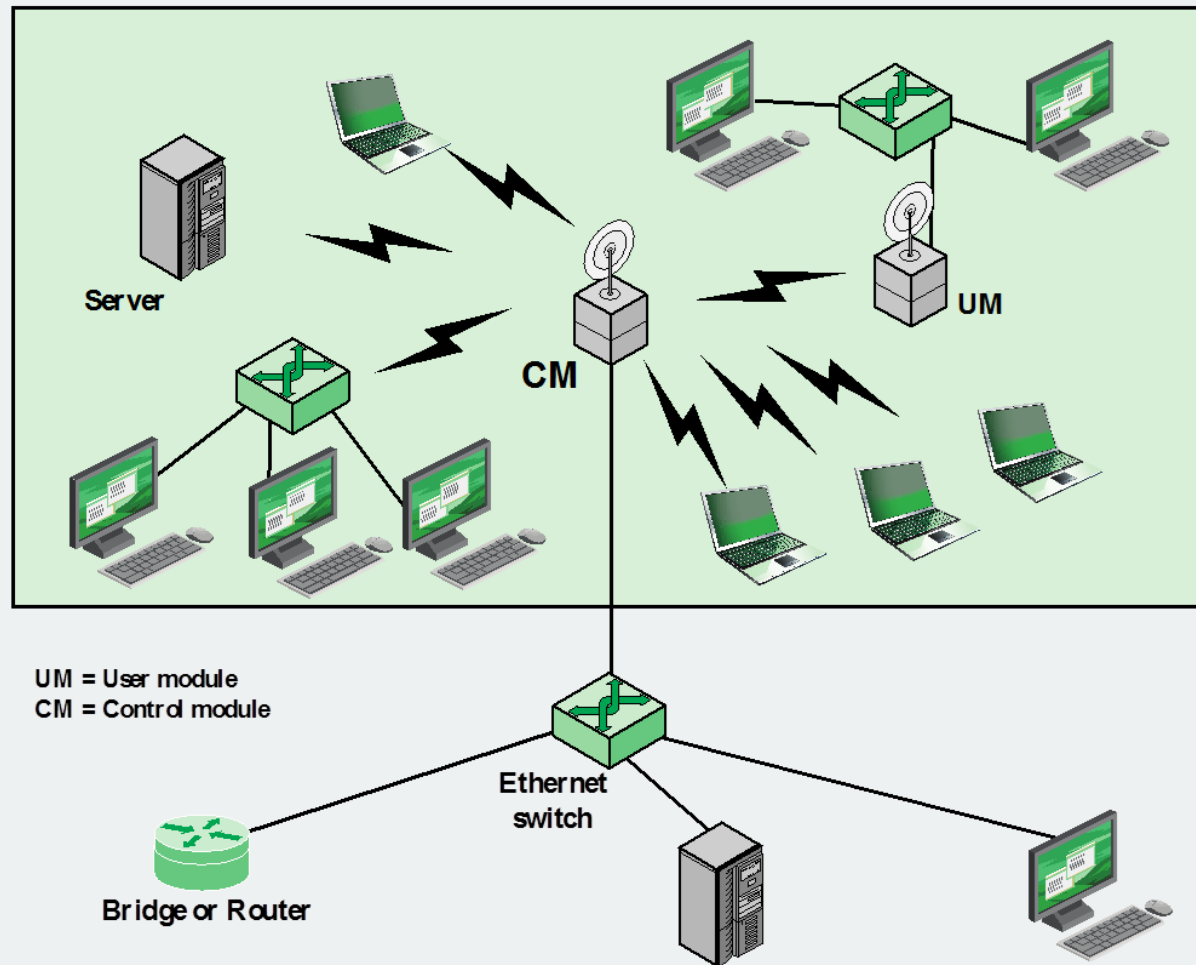

Figure 13.1 Example Single-Cell Wireless LAN Configuration

System med flera accesspunkter

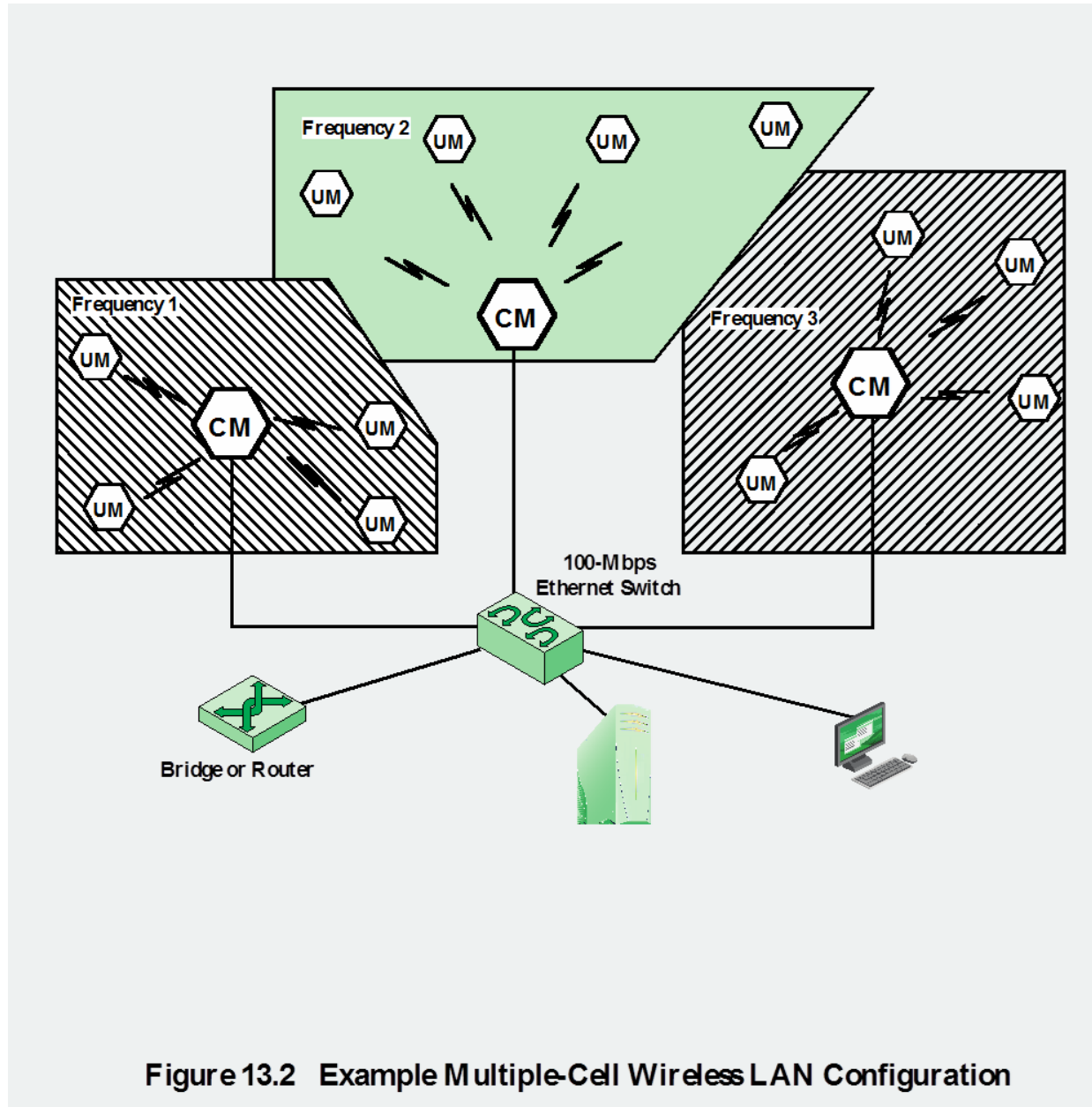
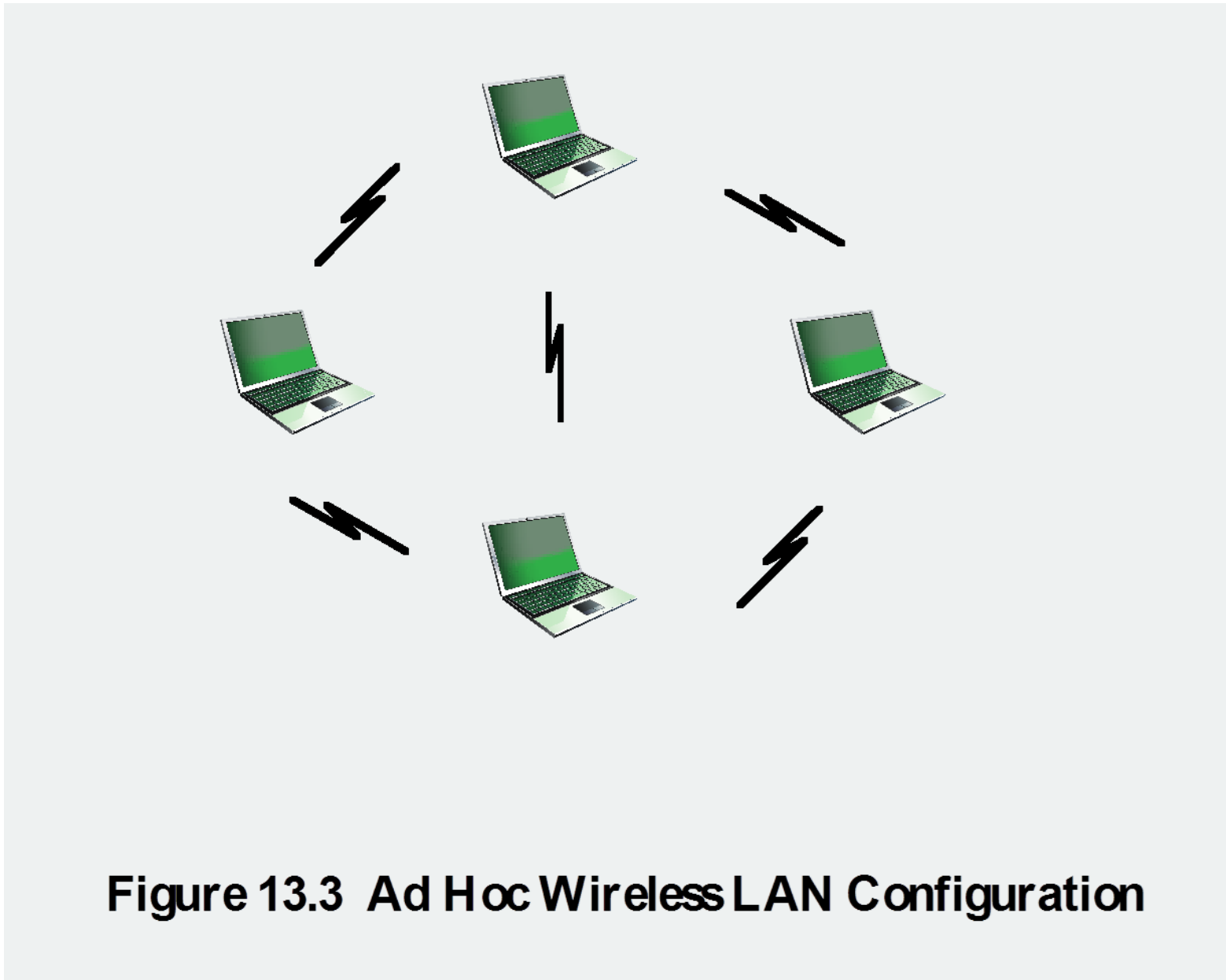

Figure 13.2 Example Multiple-Cell Wireless LAN Configuration

Ad Hoc (ingen accesspunkt)



Wireless LAN Requirements

- Throughput
- Number of nodes
- Connection to backbone LAN
- Service area (typical diameter 100-300 m)
- Battery power consumption
- Transmission robustness and security
- Collocated network operation
- License-free operation (2.4 GHz and 5 GHz)
- Hand over/roaming
- Dynamic configuration

Wi-Fi Alliance

- Need for standardization
- Wireless Ethernet Compatibility Alliance (WECA)
 - Industry consortium formed in 1999
- Renamed the Wi-Fi (Wireless Fidelity) Alliance
 - Created a test suite to certify interoperability for 802.11 products

Table 13.1

Key IEEE 802.11 Standards

Standard	Scope
IEEE 802.11a	Physical layer: 5-GHz OFDM at rates from 6 to 54 Mbps
IEEE 802.11b	Physical layer: 2.4-GHz DSSS at 5.5 and 11 Mbps
IEEE 802.11c	Bridge operation at 802.11 MAC layer
IEEE 802.11d	Physical layer: Extend operation of 802.11 WLANs to new regulatory domains (countries)
IEEE 802.11e	MAC: Enhance to improve quality of service and enhance security mechanisms
IEEE 802.11g	Physical layer: Extend 802.11b to data rates >20 Mbps
IEEE 802.11i	MAC: Enhance security and authentication mechanisms
IEEE 802.11n	Physical/MAC: Enhancements to enable higher throughput
IEEE 802.11T	Recommended practice for the evaluation of 802.11 wireless performance
IEEE 802.11ac	Physical/MAC: Enhancements to support 0.5–1 Gbps in 5-GHz band
IEEE 802.11ad	Physical/MAC: Enhancements to support ≥ 1 Gbps in the 60-GHz band

(Table can be found on page 424 in the textbook)

Table 13.2

IEEE 802.11 Terminology

Access point (AP)	Any entity that has station functionality and provides access to the distribution system via the wireless medium for associated stations
Basic service set (BSS)	A set of stations controlled by a single coordination function
Coordination function	The logical function that determines when a station operating within a BSS is permitted to transmit and may be able to receive PDUs
Distribution system (DS)	A system used to interconnect a set of BSSs and integrated LANs to create an ESS
Extended service set (ESS)	A set of one or more interconnected BSSs and integrated LANs that appear as a single BSS to the LLC layer at any station associated with one of these BSSs
Frame	Synonym for MAC protocol data unit
MAC protocol data unit (MPDU)	The unit of data exchanged between two peer MAC entities using the services of the physical layer
MAC service data unit (MSDU)	Information that is delivered as a unit between MAC users
Station	Any device that contains an IEEE 802.11 conformant MAC and physical layer

Medium Access Control

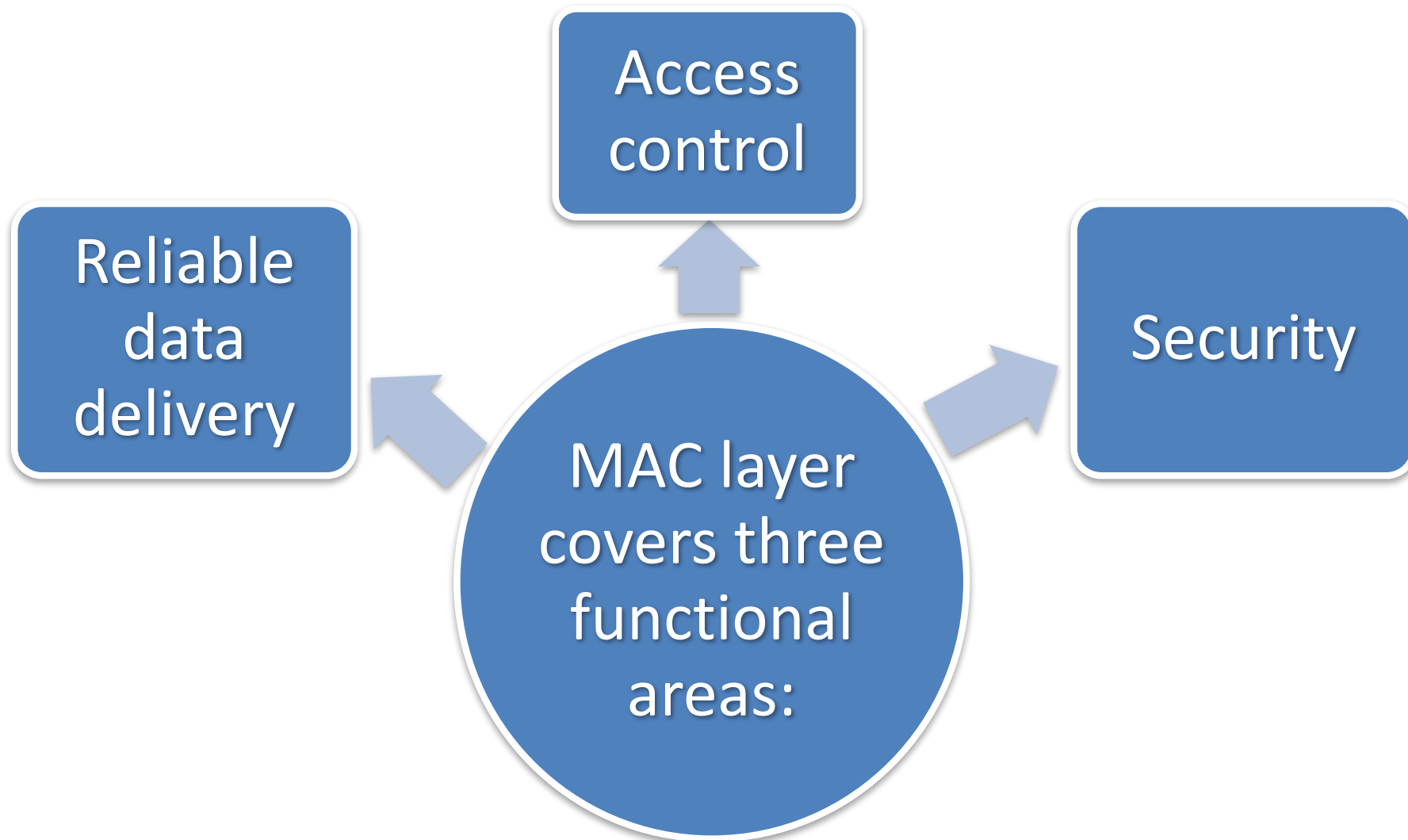

Reliable Data Delivery

- Can be dealt with at a higher layer
- More efficient to deal with errors at MAC level
- 802.11 includes frame exchange protocol
 - Station receiving frame returns acknowledgment (ACK) frame
 - Exchange treated as atomic unit
 - If no ACK within short period of time, retransmit
- 802.11 physical and MAC layers unreliable
 - Includes a CRC
 - Error detection results in loss of frames

Hidden Node/Station Problem

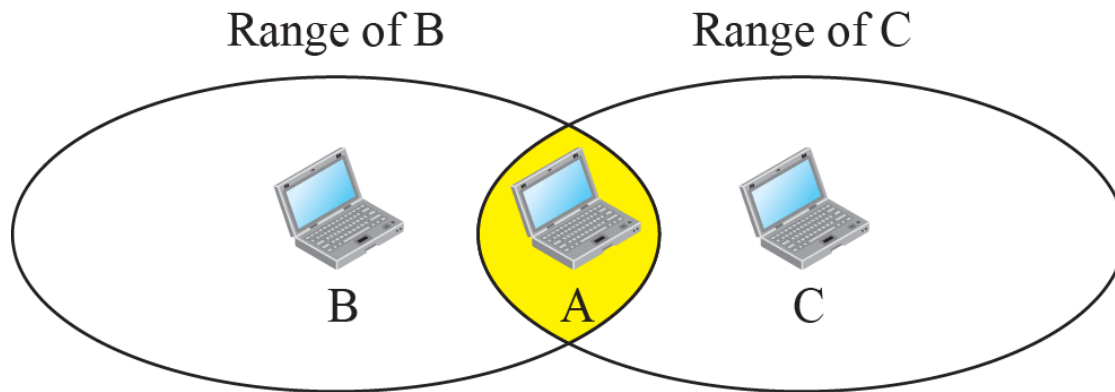

a. Stations B and C are not in each other's range.

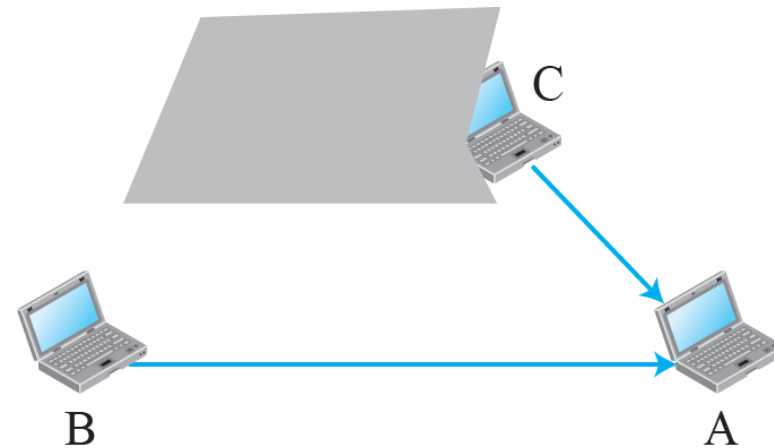

b. Stations B and C are hidden from each other.

Four Frame Exchange

- RTS alerts all stations within range of source that exchange is under way
- CTS alerts all stations within range of destination
- Other stations don't transmit to avoid collision
- RTS/CTS exchange is a required function of MAC but may be disabled
- Can use four-frame exchange for better reliability

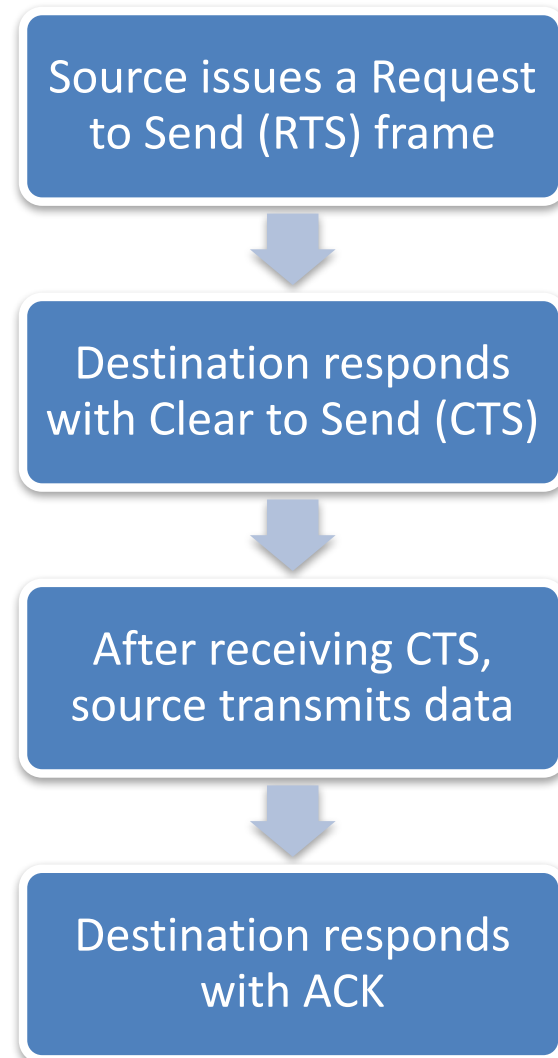

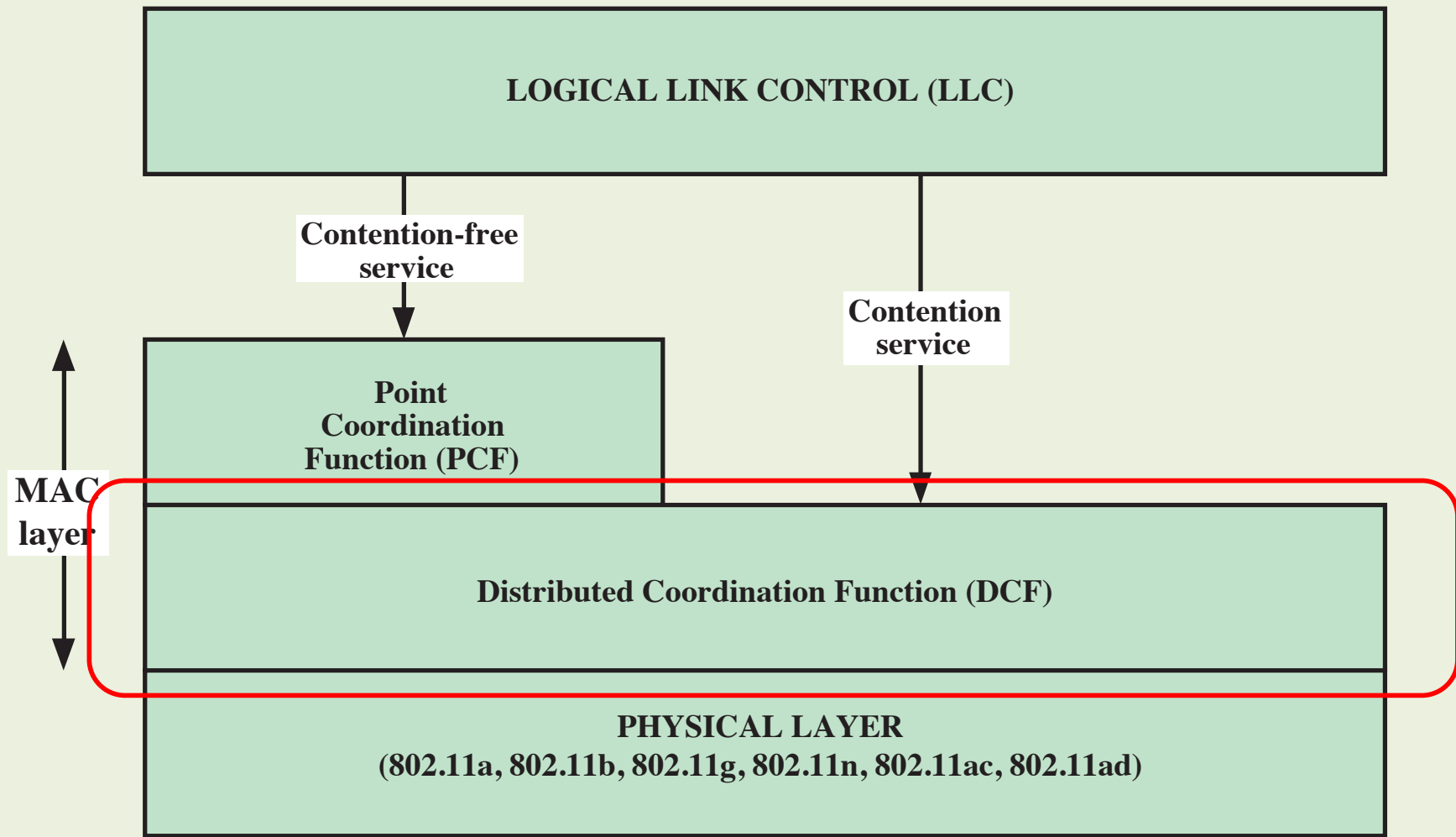
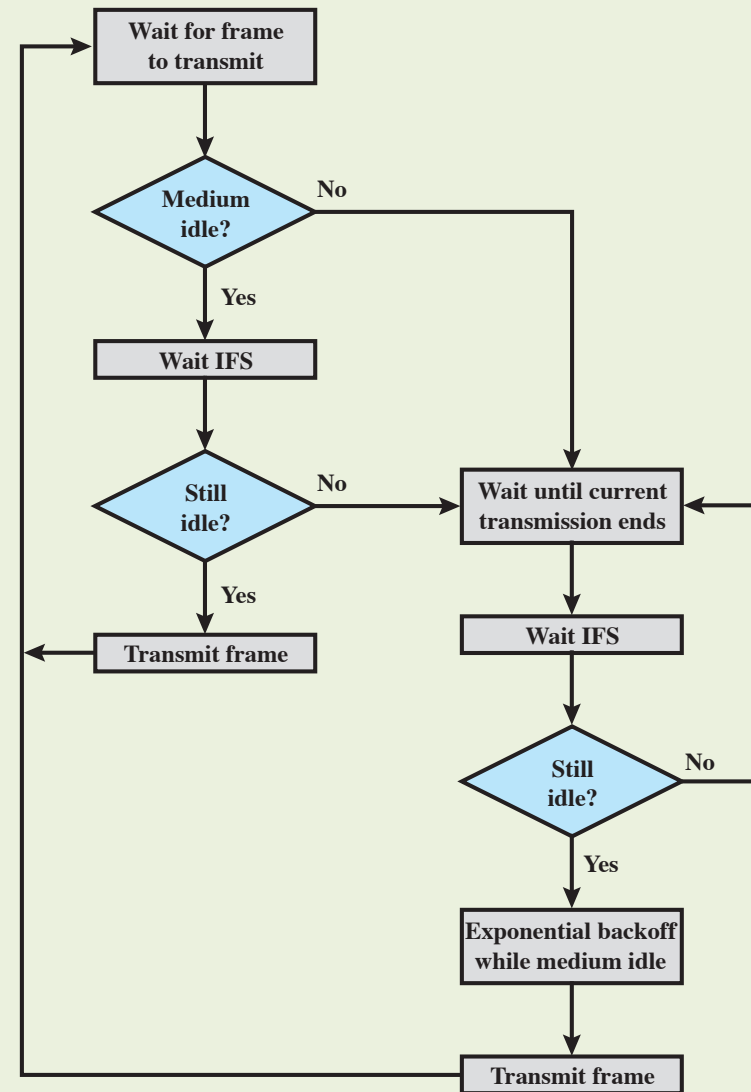

Figure 13.5 IEEE 802.11 Protocol Architecture

Distributed Coordination Function (DCF)

- DCF sublayer uses CSMA algorithm
- Does not include a collision detection function because it is not practical on a wireless network
- Includes a set of delays that amounts as a priority scheme



Priority IFS Values

SIFS
(short IFS)

For all
immediate
response
actions

PIFS
(point coordination
function IFS)

Used by the
centralized
controller in
PCF scheme
when issuing
polls

DIFS
(distributed
coordination function
IFS)

Used as
minimum
delay for
asynchronous
frames
contending
for access

802.11 MAC ramformat

Två ramtyper

- Kontroll
- Data

Notera fyra adressfält!

- Source
- Destination
- Transmitter
- Receiver
- BSSID (addr AP)

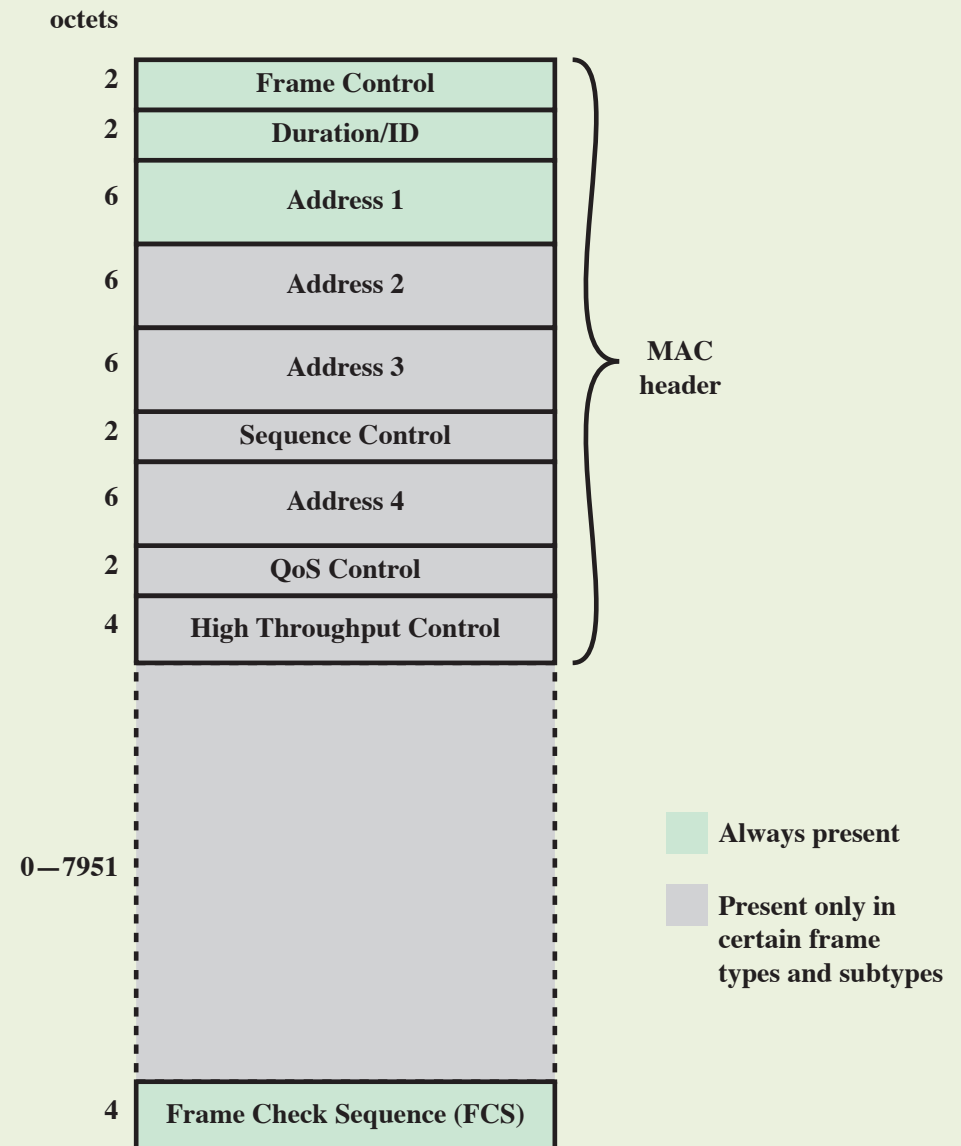

Figure 13.8 IEEE 802.11 MAC Frame Format

Table 13.4

IEEE 802.11 Physical Layer Standards

Standard	802.11a	802.11b	802.11g	802.11n	802.11ac	802.11ad
Year introduced	1999	1999	2003	2009	2012	2014
Maximum data transfer speed	54 Mbps	11 Mbps	54 Mbps	65 to 600 Mbps	78 Mbps to 3.2 Gbps	6.76 Gbps
Frequency band	5 GHz	2.4 GHz	2.4 GHz	2.4 or 5 GHz	5 GHz	60 GHz
Channel bandwidth	20 MHz	20 MHz	20 MHz	20, 40 MHz	40, 80, 160 MHz	2160 MHz
Highest order modulation	64 QAM	11 CCK	64 QAM	64 QAM	256 QAM	64 QAM
Spectrum usage	DSSS	OFDM	DSSS, OFDM	OFDM	SC-OFDM	SC, OFDM
Antenna configuration	1×1 SISO	1×1 SISO	1×1 SISO	Up to 4×4 MIMO	Up to 8×8 MIMO, MU-MIMO	1×1 SISO

(Table is on page 436 in textbook)

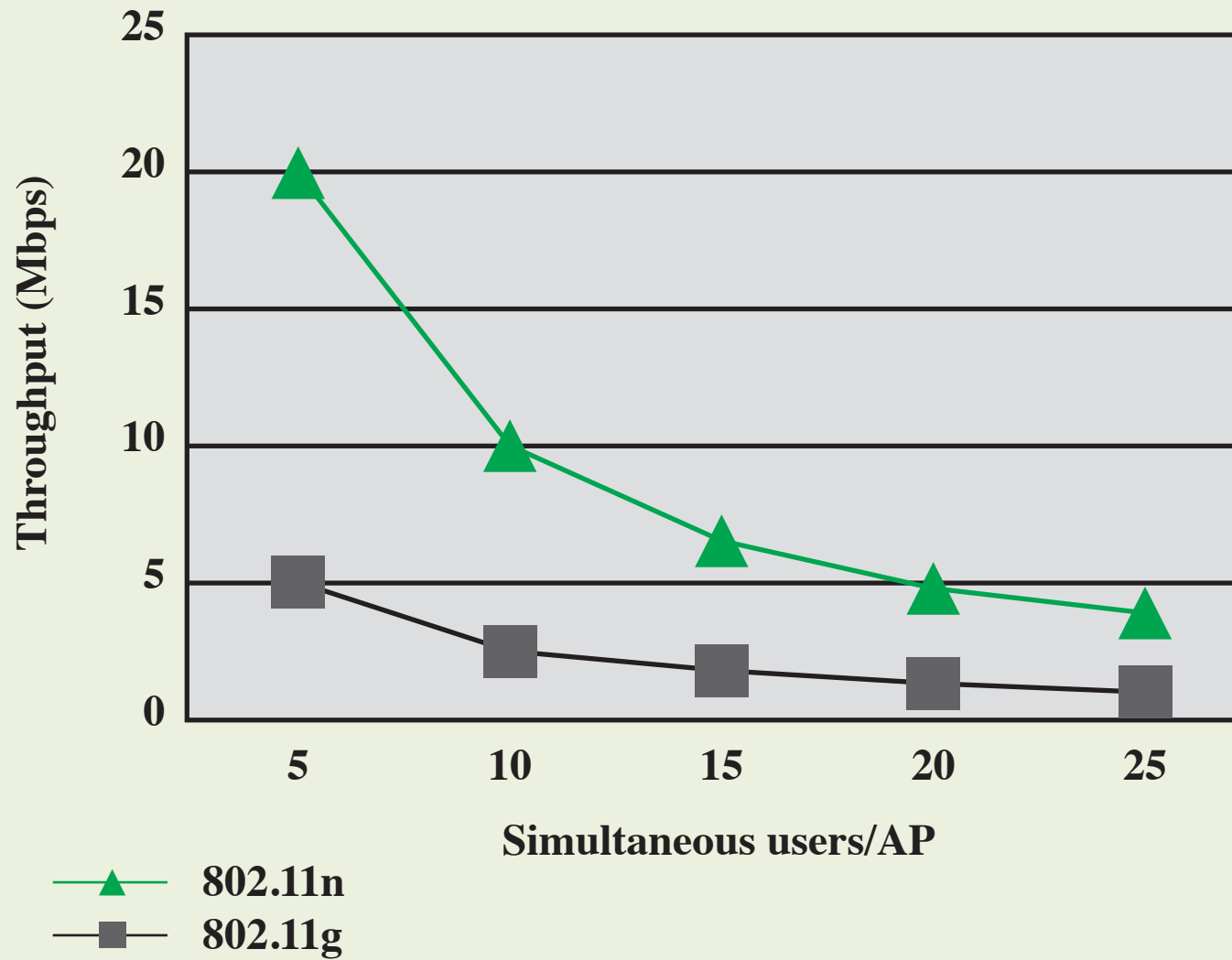

802.11ac (2013) Multi-user MIMO: 430 Mbps/spatial stream
 802.11ax (est 2018)