



Lecture no: **9**

## Multiple access and cellular systems

Ove Edfors, Department of Electrical and Information Technology  
Ove.Edfors@eit.lth.se



# Contents

- Background
- Interference and spectrum efficiency
- Frequency-division multiple access (FDMA)
- Time-division multiple access (TDMA)
- Code-division multiple access (CDMA)



# BACKGROUND

# Background



When there are more than one user/terminal that needs to access a certain resource, we say that we have **multiple access (MA)**.

In wireless systems, MA usually means the technique by which we share a common radio resource to establish communication channels between terminals and base stations.

Different techniques have different properties, such as:

- Continuous or discontinuous channel availability
- Required level of centralized control
- Interference in the system
- Flexibility of available bandwidth/data rate
- Transmitter/receiver complexity
- Spectral efficiency

Depending on the intended application, one or several of these properties are more important than others.



# MULTIPLE ACCESS

## Freq.-division multiple access (FDMA)

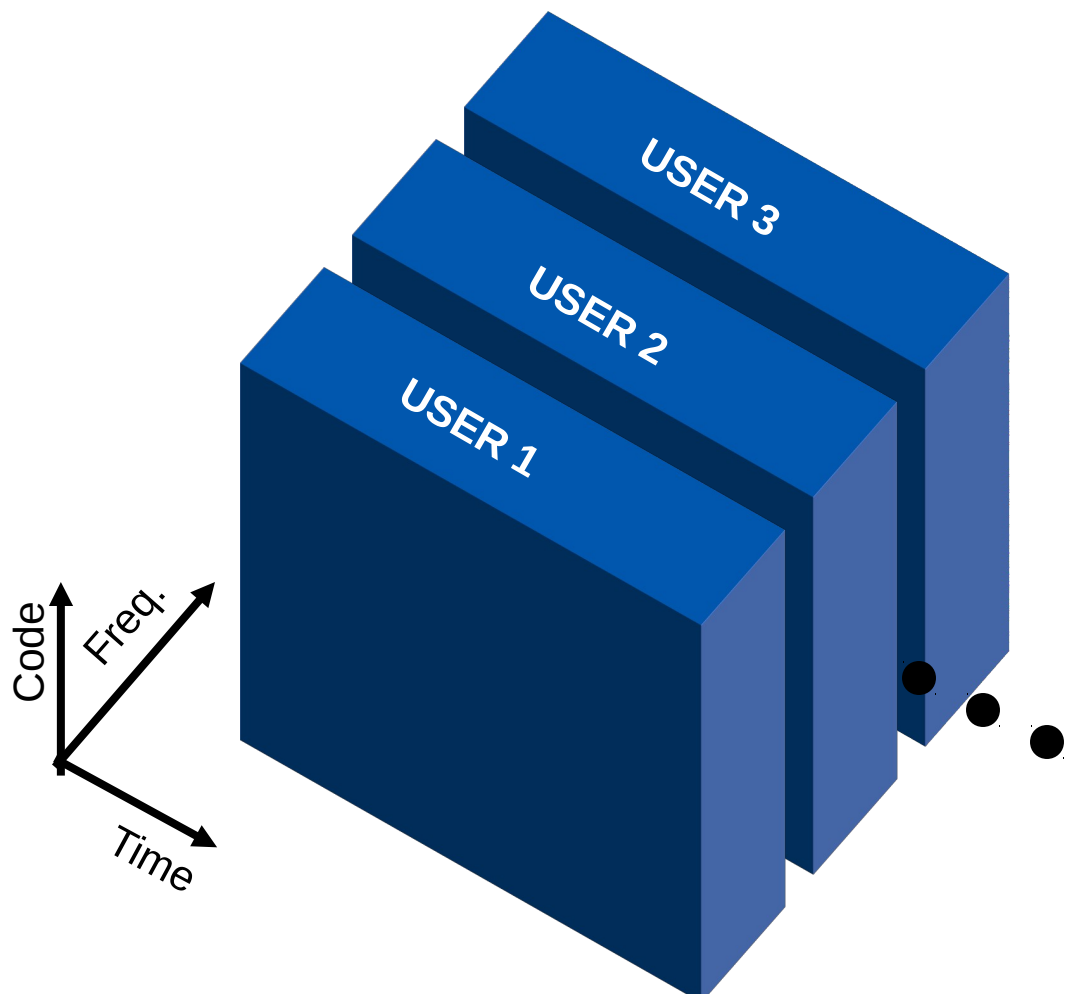

Users are separated in frequency bands.

Examples: Nordic Mobile Telephony (NMT), Advanced Mobile Phone System (AMPS)



# MULTIPLE ACCESS

## Time-division multiple access (TDMA)

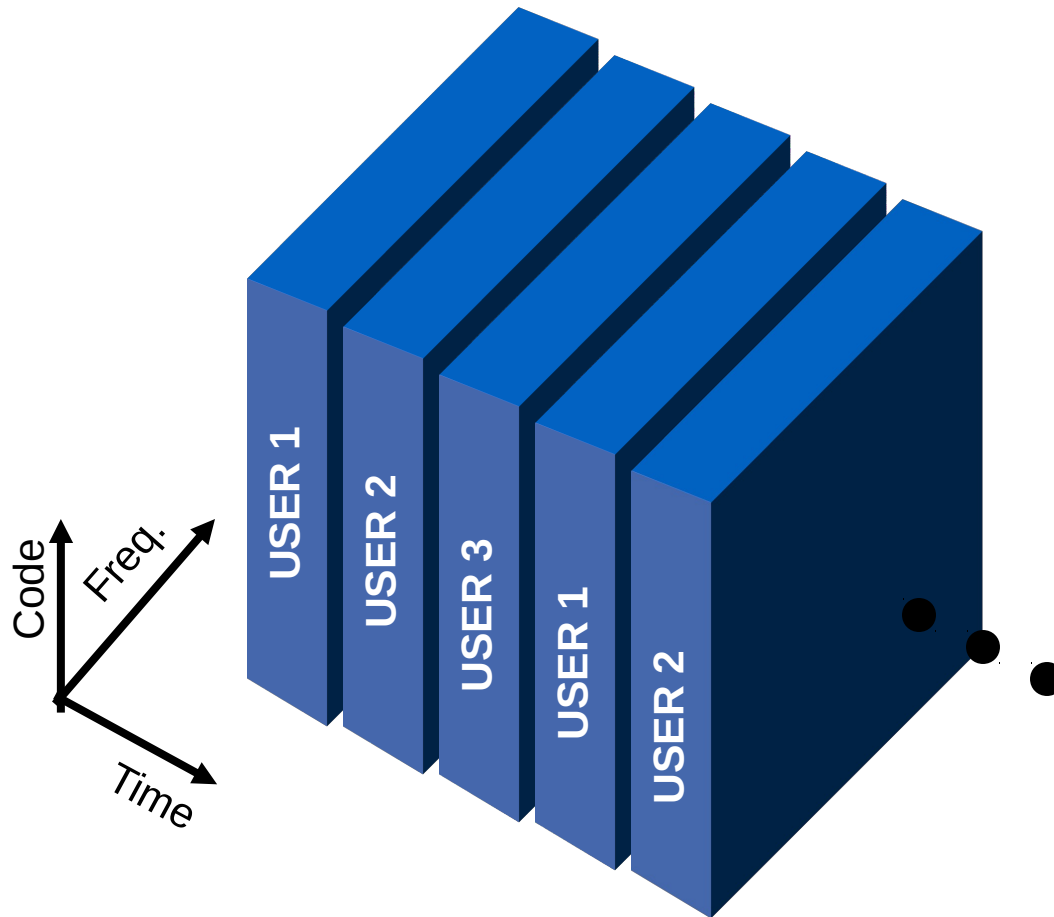

Users are separated in time slots.

Example: Global System for Mobile communications (GSM)



# MULTIPLE ACCESS

## Code-division multiple access (CDMA)

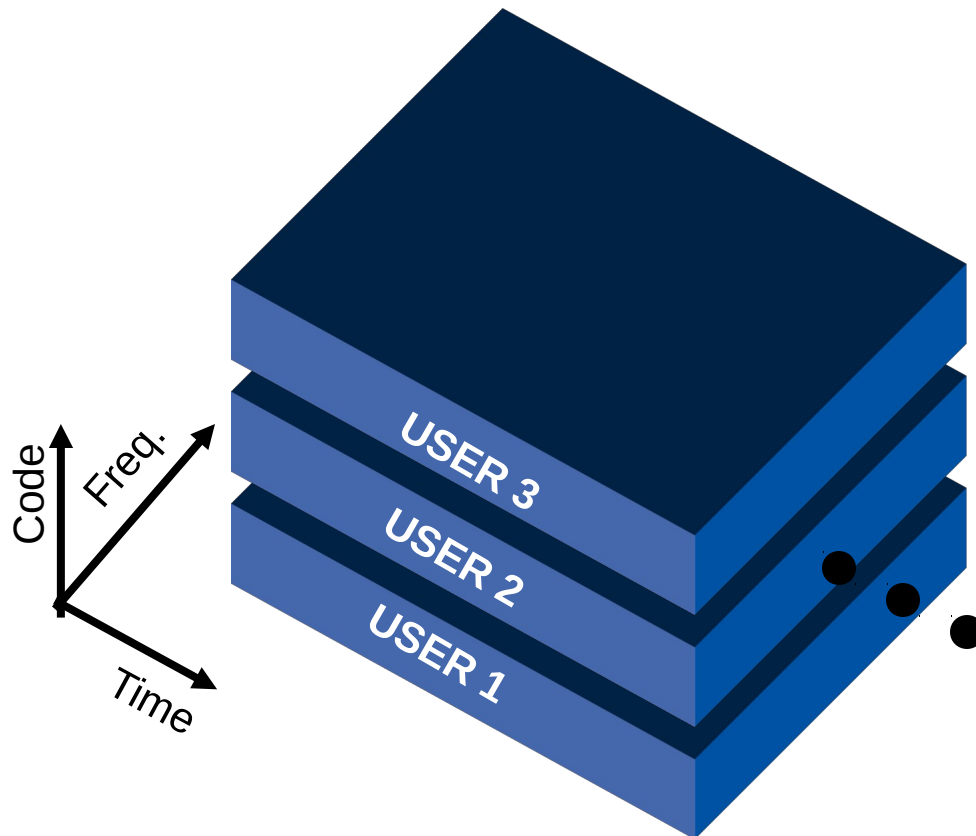

Users are separated by spreading codes.

Examples: CdmaOne, Wideband CDMA (WCDMA), Cdma2000



# MULTIPLE ACCESS

## Carrier-sense multiple access (CSMA)

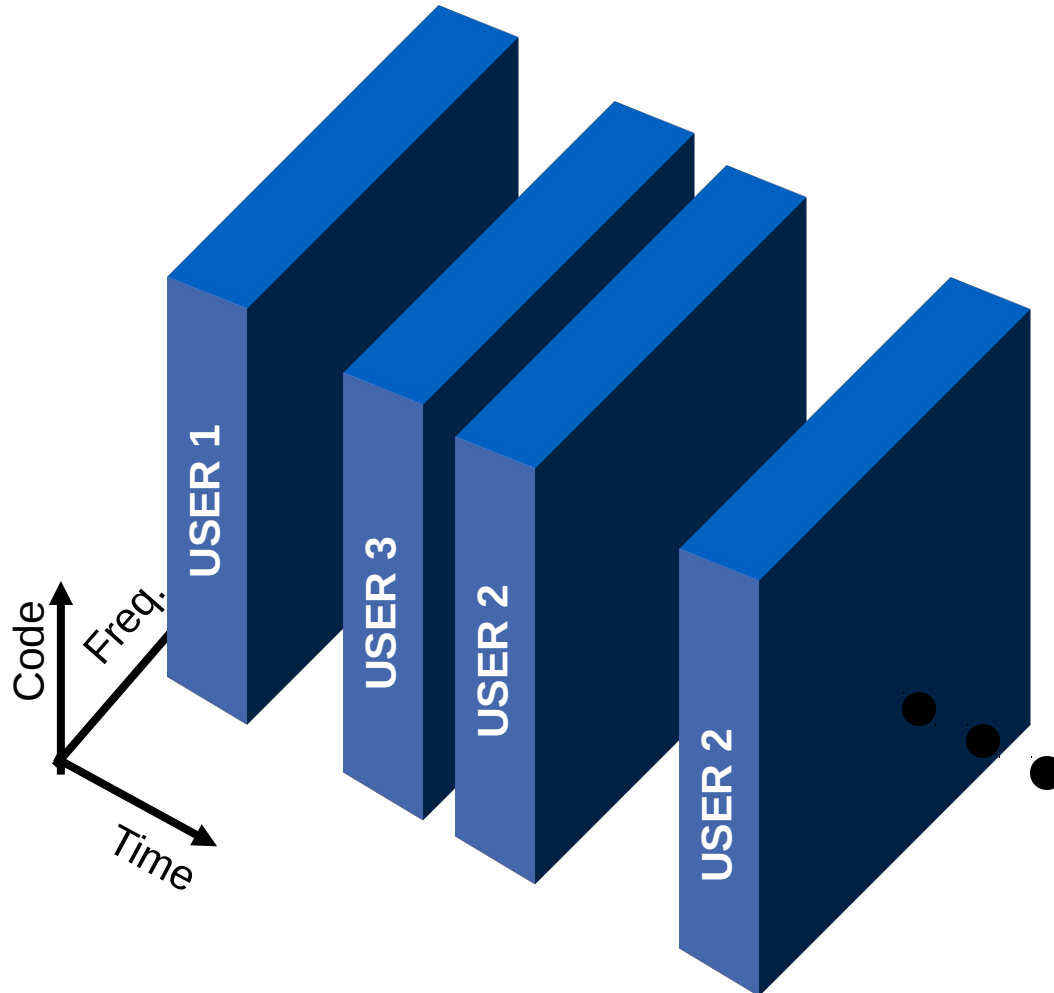

Users are separated in time but not in an organized way. The terminal listens to the channel, and transmits a packet if it's free.

Collisions can occur and data is lost.

Example: IEEE 802.11 (WLAN)





# INTERFERENCE AND SPECTRUM EFFICIENCY

# Interference and spectrum efficiency

## Noise and interference limited links

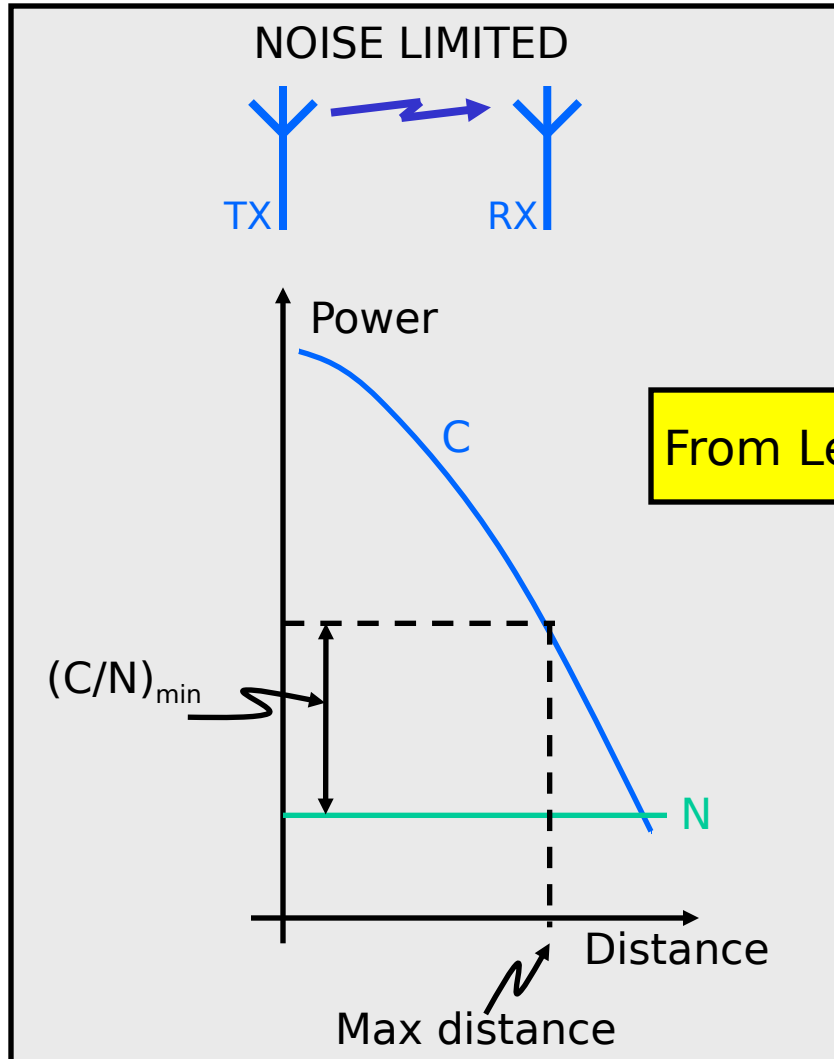

From Lecture 1

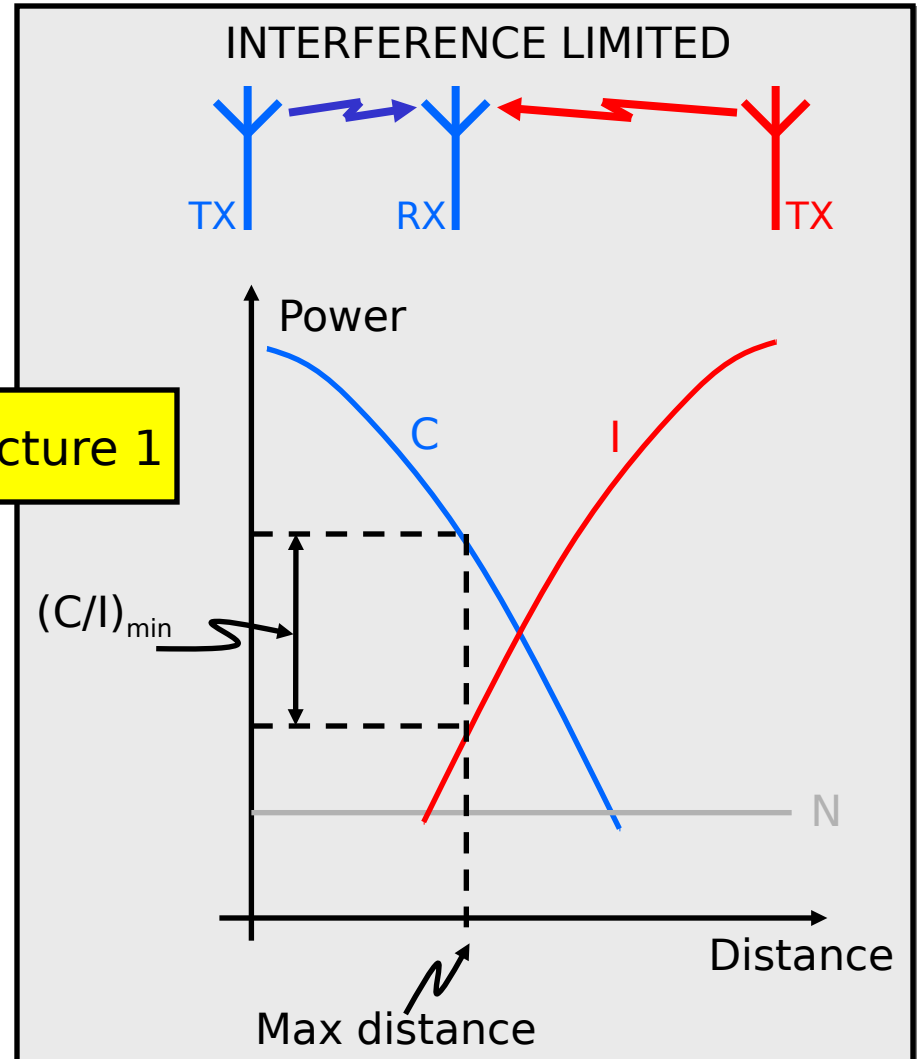

# Interference and spectrum efficiency

## Cellular systems



Let us assume that we have a cellular system with a regular hexagonal cell structure.

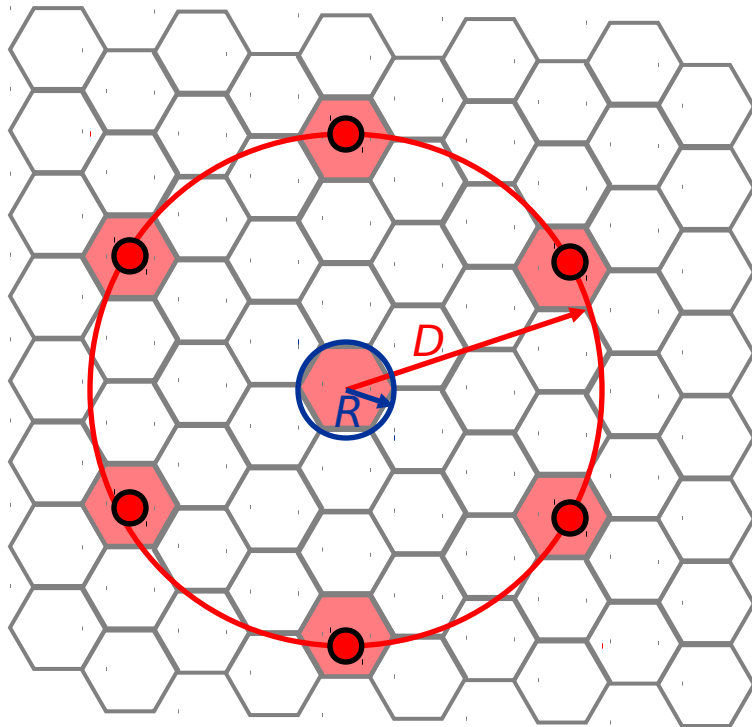

The radius of a cell is  $R$ .

The distance to the closest co-channel base-stations (first tier) is  $D$ .

To achieve this reuse ratio  $D/R$ , we need to split the available radio resource into

$$N_{cluster} = \frac{(D/R)^2}{3}$$

shares and split them among an equal number of base stations.

Note: Only certain  $D/R$  will result in useful cluster sizes.

# Interference and spectrum efficiency

## Cellular systems, cont.



Cluster size:  $N_{\text{cluster}} = 4$

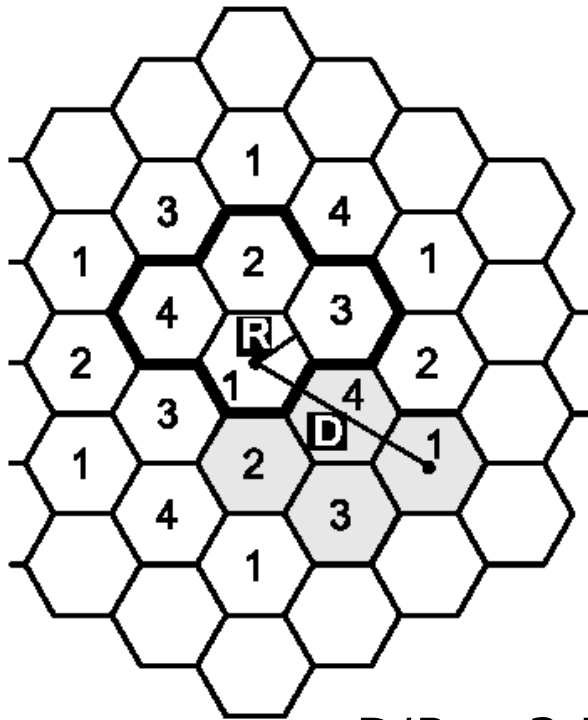

$D/R = 3.5$

Cluster size:  $N_{\text{cluster}} = 13$

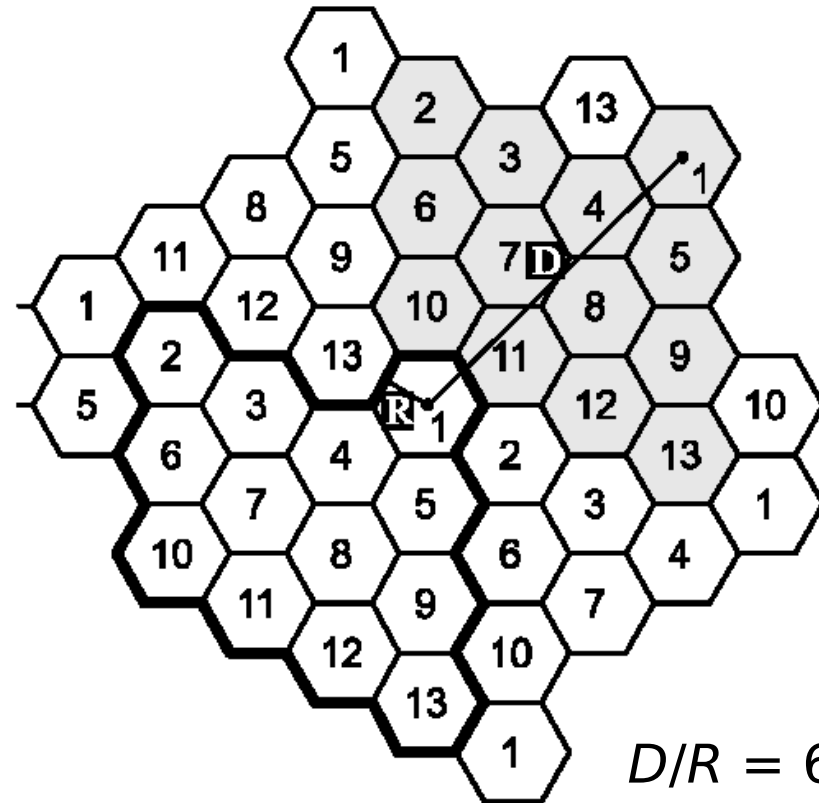

$D/R = 6.2$

# Interference and spectrum efficiency

## Cellular systems, cont.



Where do we get the necessary  $D/R$ ?

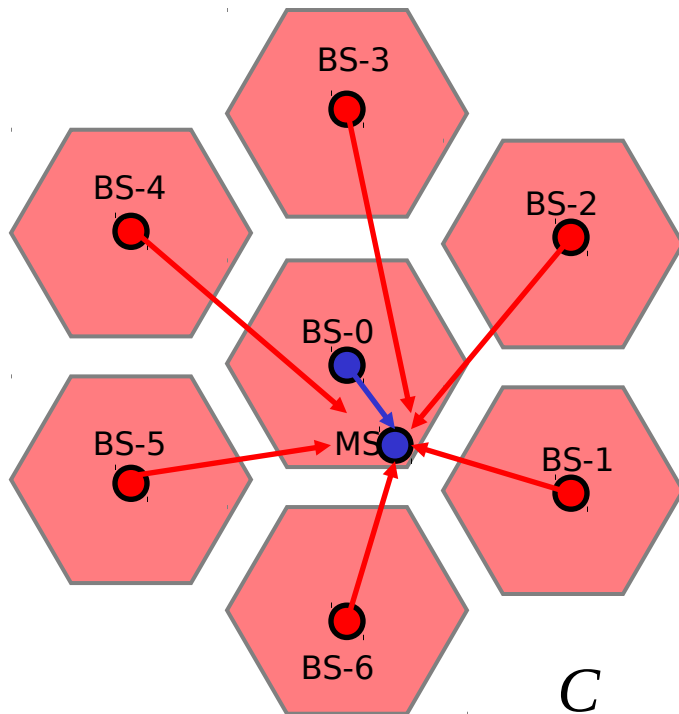

Let the propagation exponent be  $\eta$  and  $d_0$  the distance between BS-0 and MS. Then the received useful power is

$$C \sim P_{\text{TX}} d_0^{-\eta}$$

With 6 co-channel cells interfering, at distances  $d_1, d_2, \dots, d_6$ , from the MS, the received interference is

$$I \sim \sum_{i=1}^6 P_{\text{TX}} d_i^{-\eta}$$

Knowing that  $d_0 < R$  and  $d_1, \dots, d_6 > D - R$ , we get

$$\frac{C}{I} = \frac{P_{\text{TX}} d_0^{-\eta}}{\sum_{i=1}^6 P_{\text{TX}} d_i^{-\eta}} > \frac{P_{\text{TX}} R^{-\eta}}{\sum_{i=1}^6 P_{\text{TX}} (D - R)^{-\eta}} = \frac{1}{6} \left( \frac{R}{D - R} \right)^{-\eta}$$

This bound is valid for both up- and down-link.

# Interference and spectrum efficiency

## Cellular systems, cont.



Assume now that we have a transmission system, which requires  $(C/I)_{\min}$  to operate properly. Further, due to fading and requirements on outage we need a fading margin  $M$ .

Using our bound

$$\frac{C}{I} > \frac{1}{6} \left( \frac{R}{D-R} \right)^{-\eta}$$

We get

$$\frac{D}{R} \geq \left( 6 M \left( \frac{C}{I} \right)_{\min} \right)^{1/\eta} + 1$$

we can solve for a “safe”  $D/R$  by requiring

$$\frac{1}{6} \left( \frac{R}{D-R} \right)^{-\eta} \geq M \left( \frac{C}{I} \right)_{\min}$$

Knowing the minimal  $C/I$  required and the necessary fading margin  $M$ , we can find a safe value on  $D/R$ .

# Interference and spectrum efficiency

## Cellular systems, cont.



When we have found our  $D/R$ , we can find an appropriate cluster size from, for instance, the following table:

$N_{cluster}$	3	4	7	9	12	13	16	19	21	25	27
$D/R = \sqrt{3N_{cluster}}$	3	3.5	4.6	5.2	6	6.2	6.9	7.5	7.9	8.7	9

↑  
TDMA systems,  
like GSM

↑  
Analog systems,  
like NMT

CDMA falls outside this analysis, since cluster size 1 is used and all cells use the same frequency band. We will come back to that!

# Interference and spectrum efficiency

## Cellular systems, cont.



When we have the cluster size, we can calculate the amount of resources available at each cell.

For telephony systems, is the number of speech channels per cell.

If we know the number of users in each cell, and how they make their calls, we can calculate important parameters like the probability of all speech channels being occupied when a certain user wants to make a call. This is called the **blocking probability**.



# Interference and spectrum efficiency

## Cellular systems, cont.



In the **Erlang-B** model there is no queue at the base station for users trying to make a call. If all speech channels are occupied, the user is blocked.

### Some definitions

Traffic in Erlang: One Erlang is 100% use of one channel.

Example: 2 calls of 5 minutes during an hour counts for  $2 \times 5 / 60 = 1/6$  Erlang.

Offered traffic: The amount of traffic by all users in a cell.

The Erlang-C model has a queue for users waiting to get a speech channel.

# Interference and spectrum efficiency

## Cellular systems, cont.



### Erlang-B

Relation between blocking probability and offered traffic for different number of available speech channels in a cell.

This is an important design parameter.

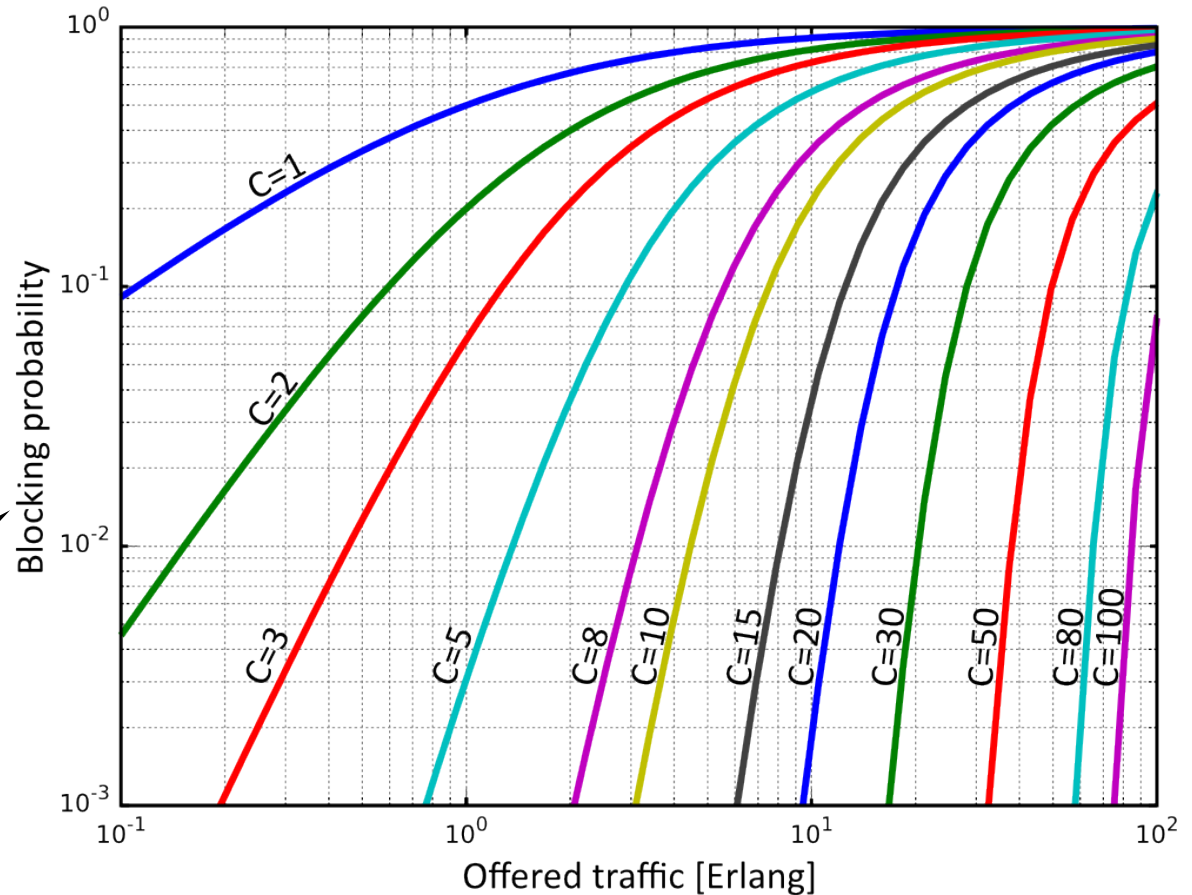

# Interference and spectrum efficiency

## Cellular systems, cont.



How do we “design a system” from a required blocking probability?

### Design input

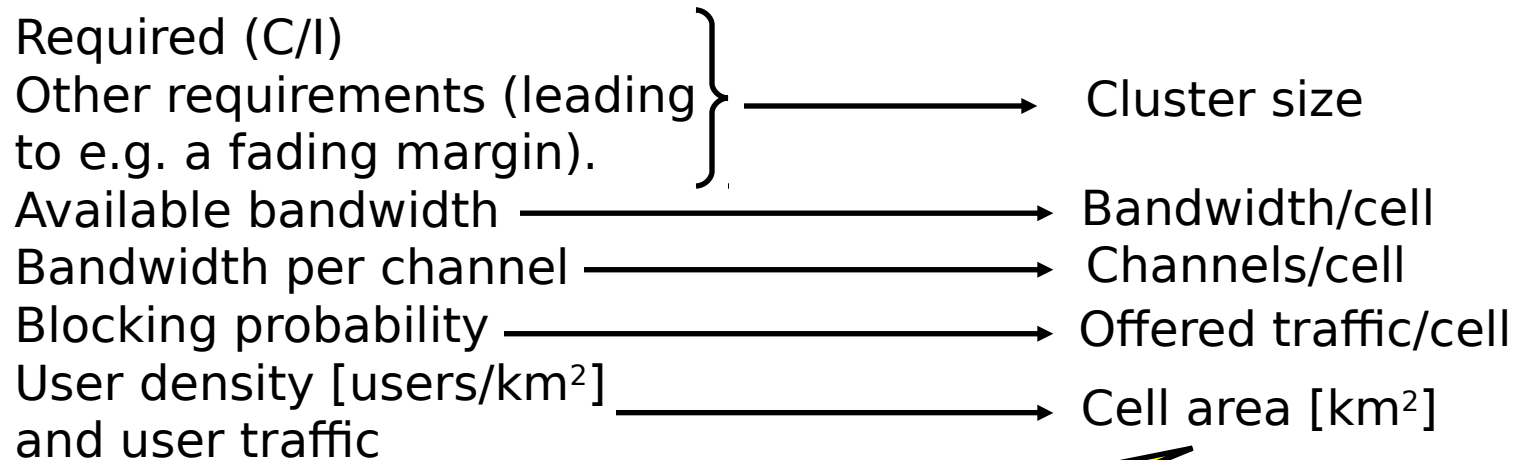

This tells the operator the number of base stations needed to cover a certain area and thus the cost of the cellular system.

This is a very simple example!



# FREQUENCY-DIVISION MULTIPLE ACCESS (FDMA)

# Freq.-division multiple access (FDMA)

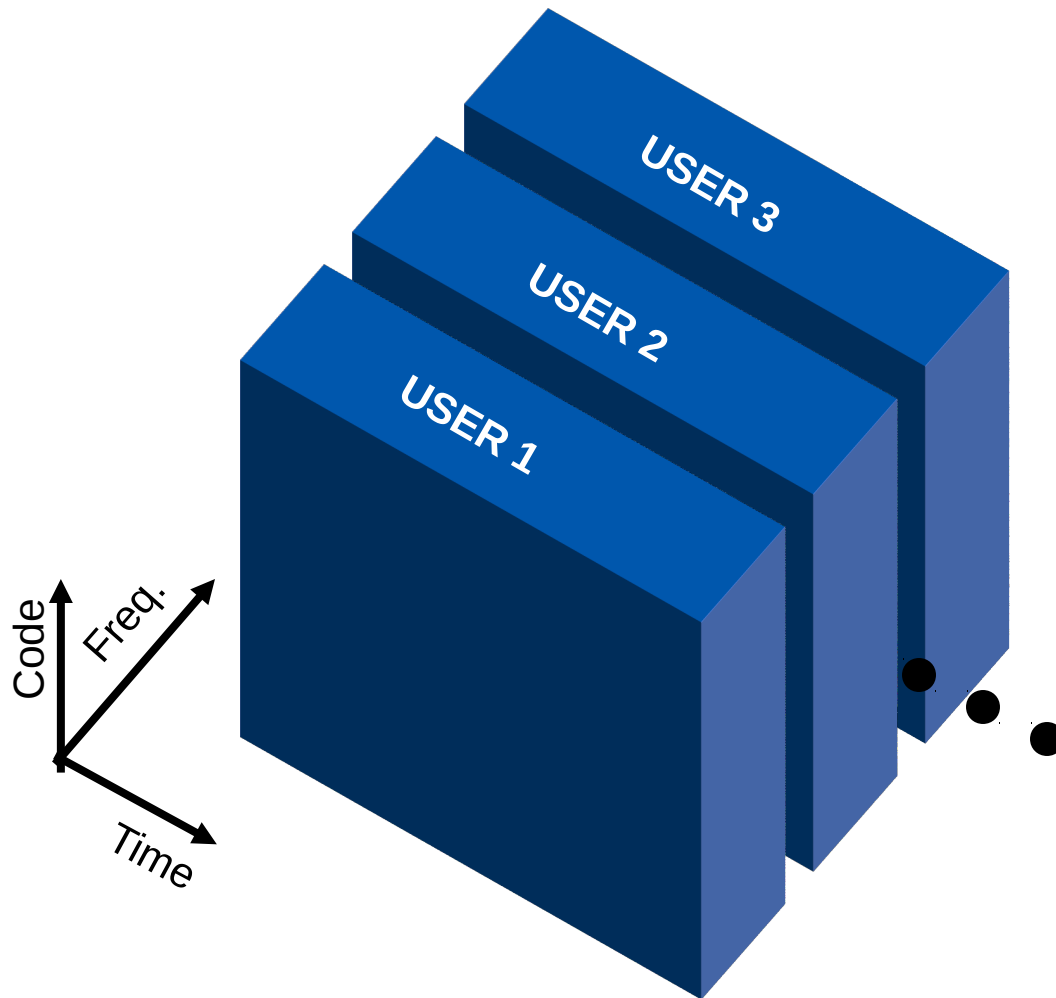

Assume that each channel has a bandwidth of  $B_{fch}$  Hz.

If the system has a total bandwidth  $B_{tot}$ , then the number of available frequency channels is

$$N_{fch} = \frac{B_{tot}}{B_{fch}}$$

Applying a cellular structure, using frequency reuse, we can have more than  $N_{fch}$  simultaneous active users.



# TIME-DIVISION MULTIPLE ACCESS (TDMA)

# Time-division multiple access (TDMA)

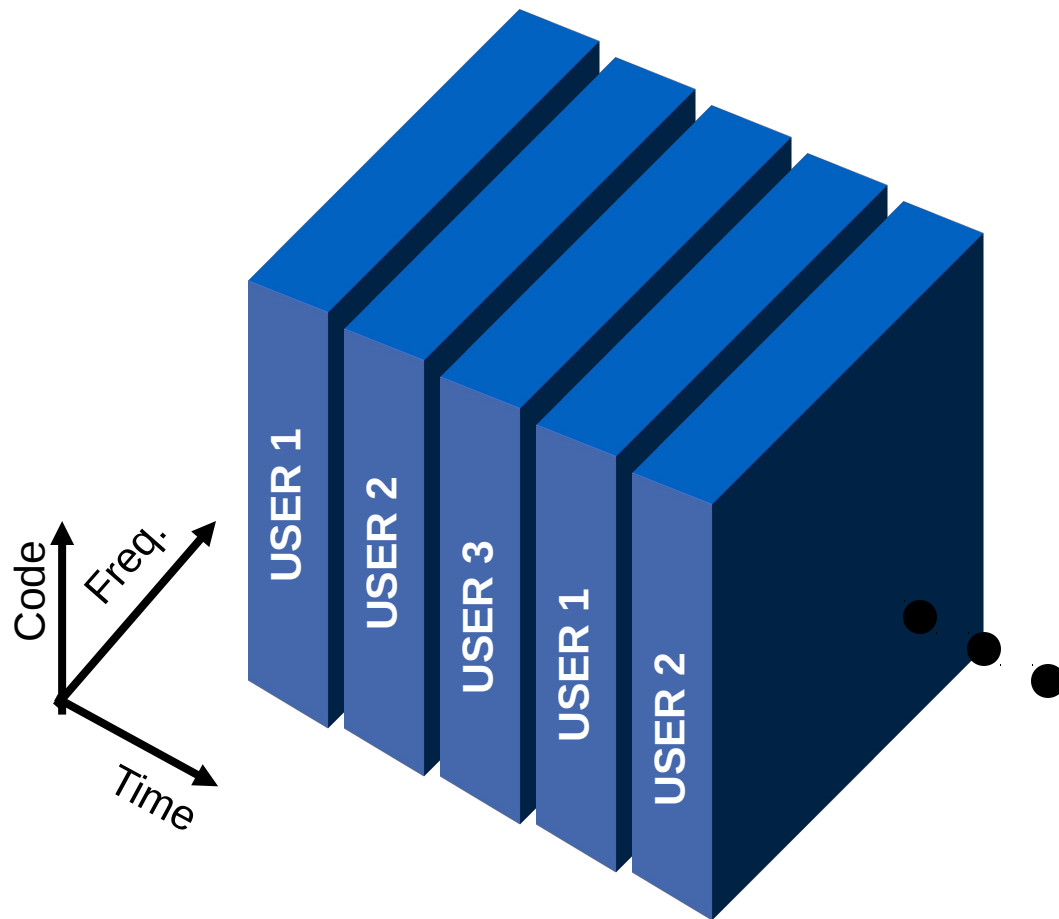

TDMA is usually combined with FDMA, where each frequency channel is subdivided in time to provide more channels.

Users within one cell use TDMA, while different cells share the radio resource in frequency.

One cell can have more than one frequency channel.

# Time-division multiple access (TDMA)



Assume that each frequency channel requires  $B_{fch}$  Hz and that the system has an available bandwidth of  $B_{tot}$  Hz. Further, each frequency channel is sub-divided into  $N$  time-divided channels.

This gives the system

$$N_{fch} = \frac{B_{tot}}{B_{fch}}$$

frequency channels, giving a total of

$$N_{ch} = N \frac{B_{tot}}{B_{fch}}$$

channels for users.

If we apply a cellular structure, sharing the frequency channels among a cluster of base stations, we can have more than  $N_{ch}$  active users in the system.





# CODE-DIVISION MULTIPLE ACCESS (CDMA)

# Code-division multiple access (CDMA)

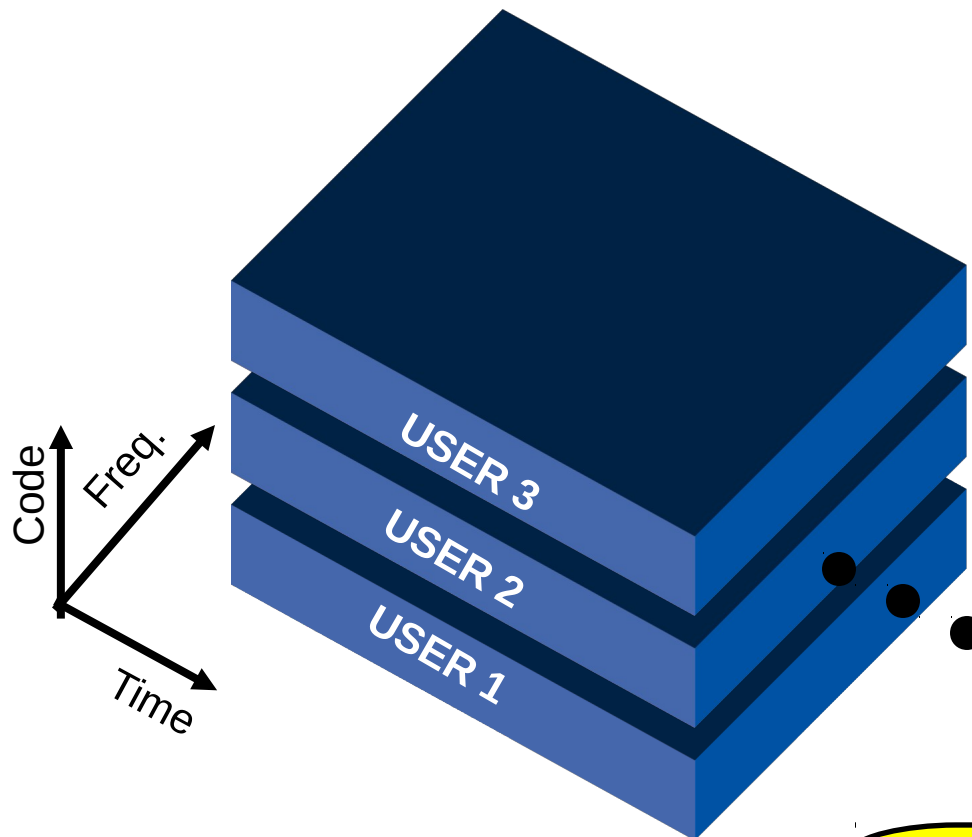

In CDMA new channels are created by assigning more spreading codes.

The available number of channels is not as firm as in FDMA and TDMA.

As long as the interference is low enough, we can open up a new channel for communication.

This definitely needs more explanation!



# Single Carrier

## The traditional way

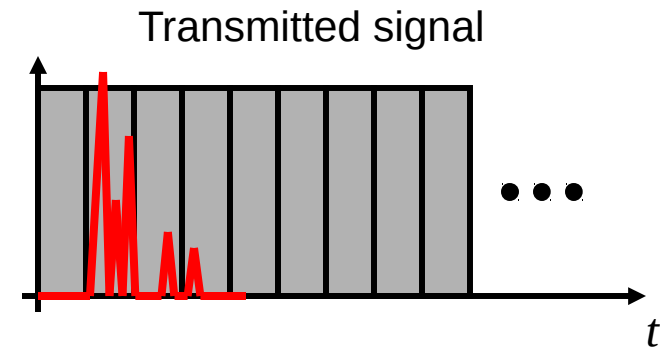
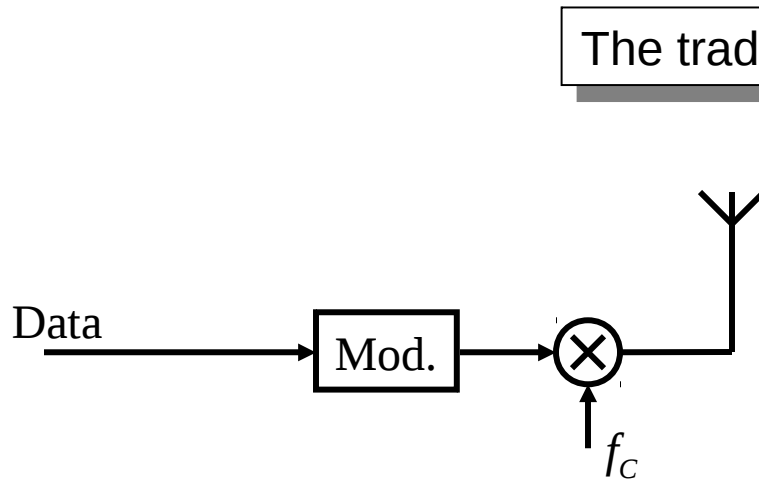

The radio symbols are short in time.

Susceptible to multipath propagation.  
(We need a channel equalizer.)

Wide radio spectrum.

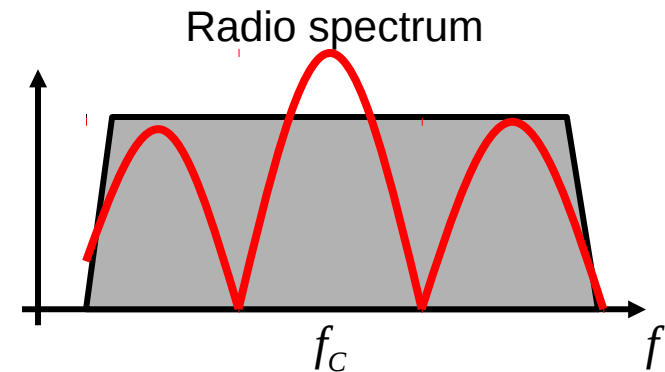



# Spread Spectrum Techniques

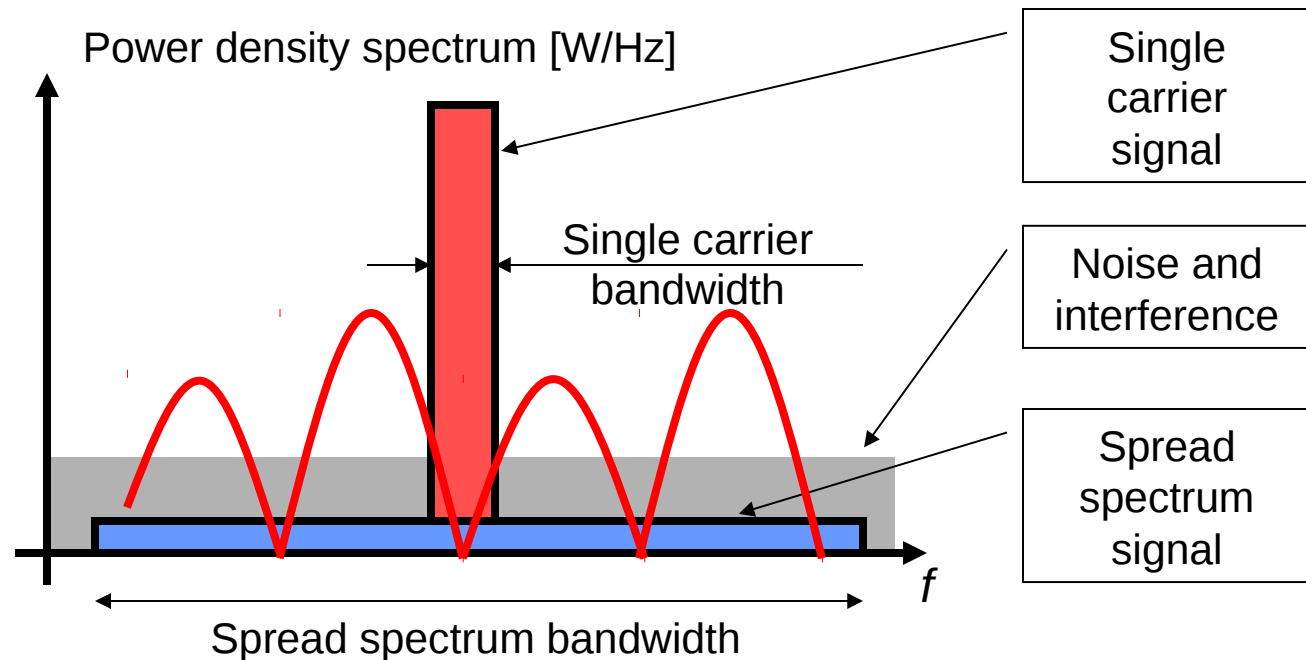

Using a bandwidth expansion  $M$ , the spread spectrum signal has  $M$  times greater bandwidth and  $M$  times lower power spectral density. ( $M$  is also called the processing gain)



# Spread Spectrum Techniques

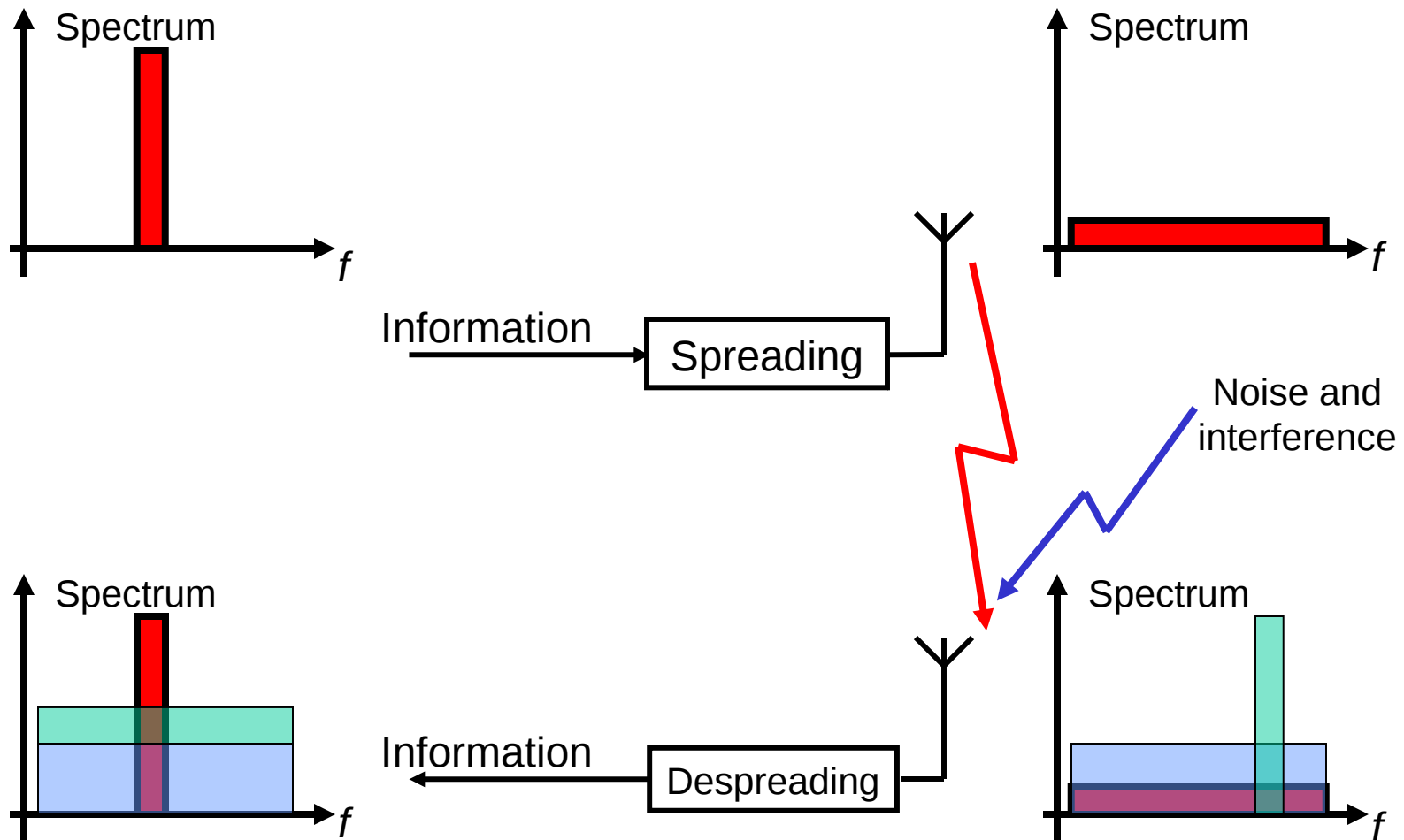

# Frequency-Hopping Spread Spectrum FHSS

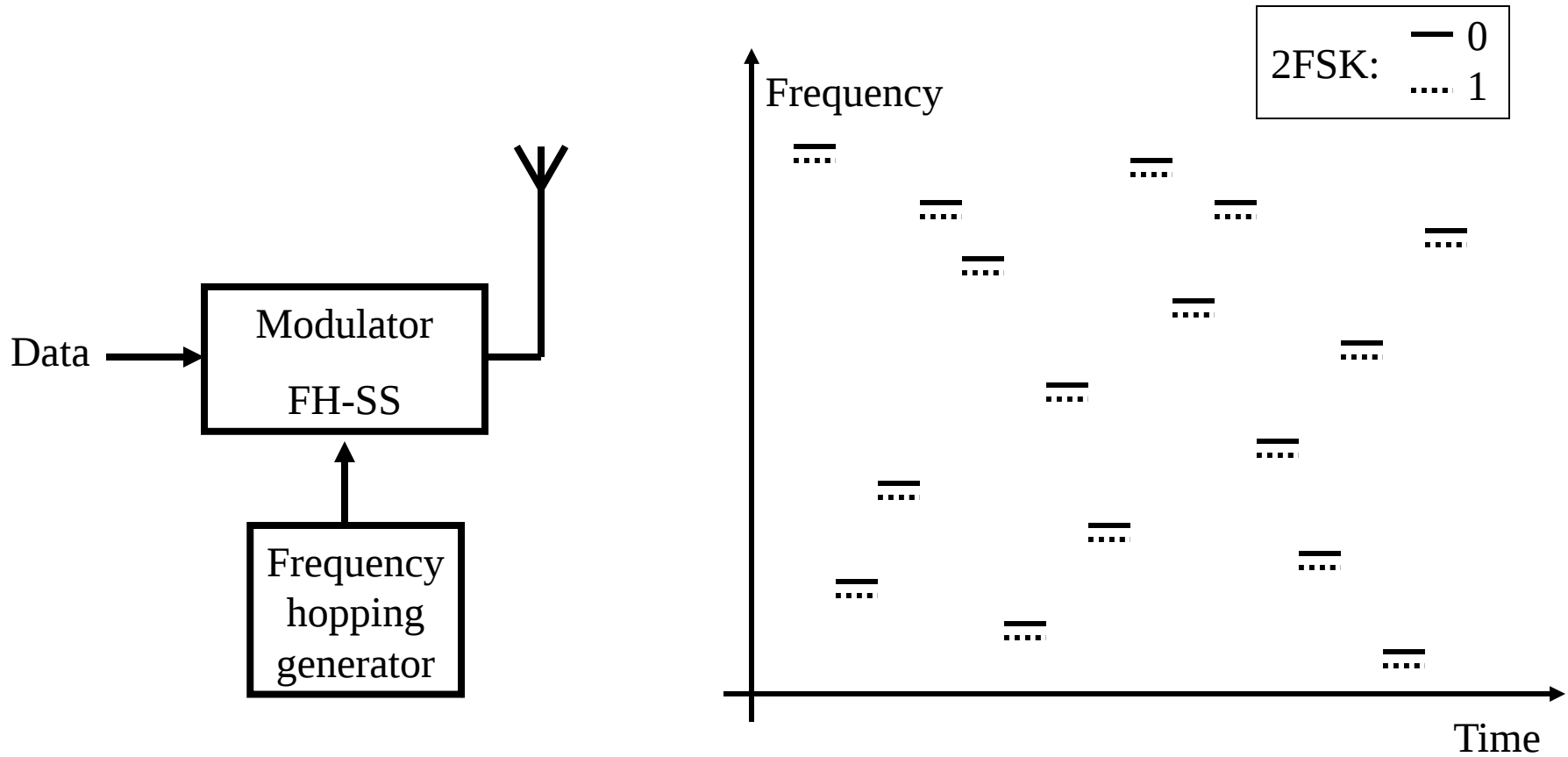

# Frequency-Hopping Spread Spectrum FHSS

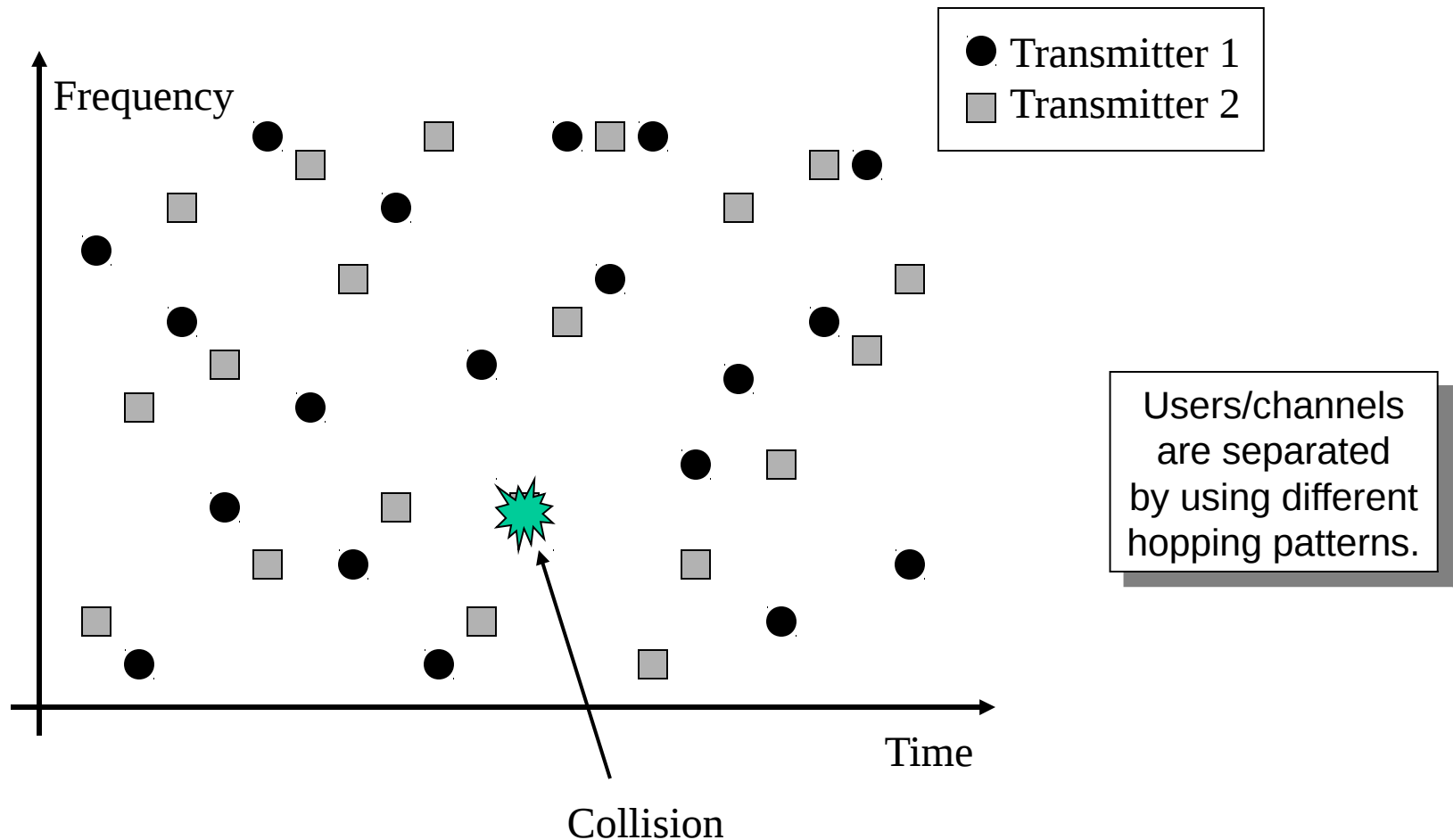

# Direct-Sequence Spread Spectrum DSSS

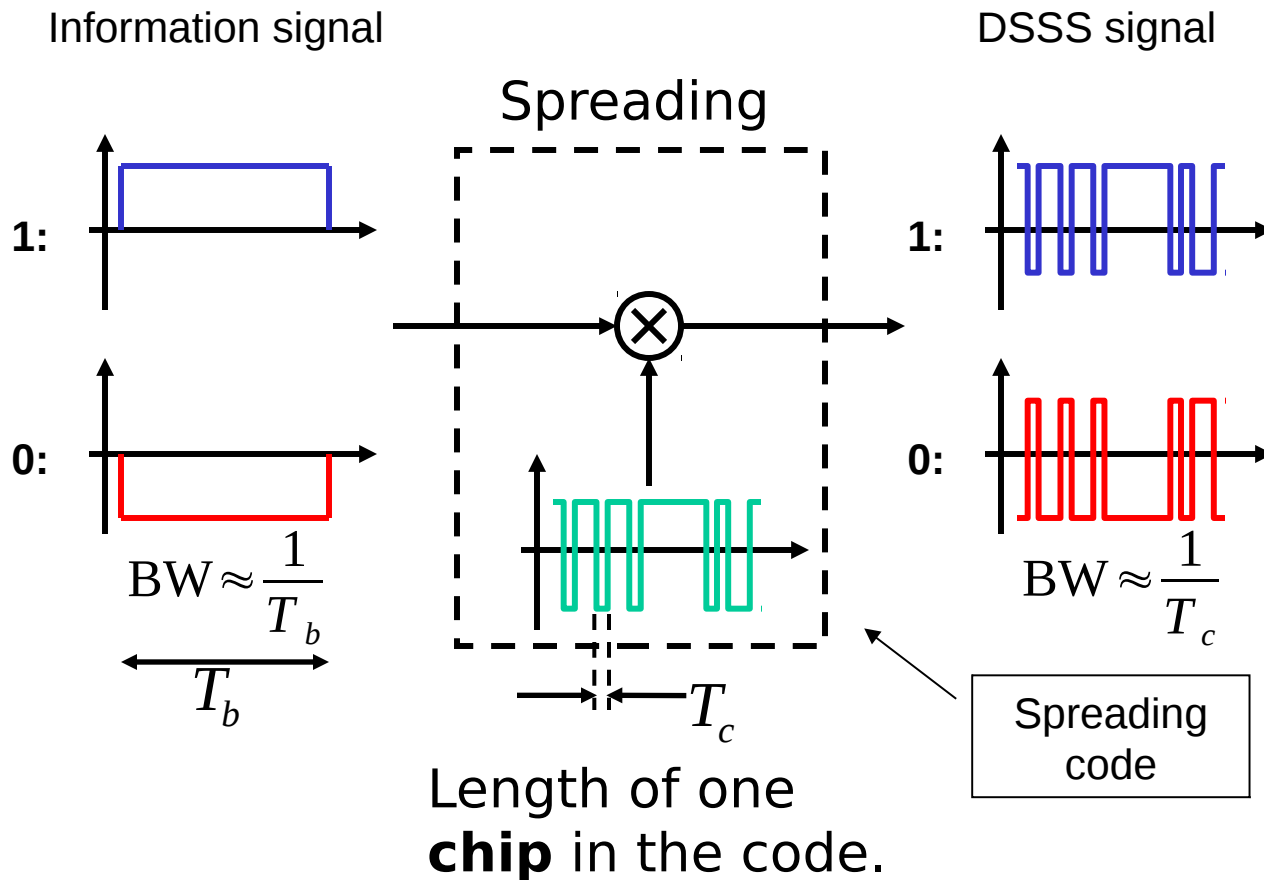

Users/channels are separated by using different spreading codes.



# Direct-Sequence Spread Spectrum DSSS

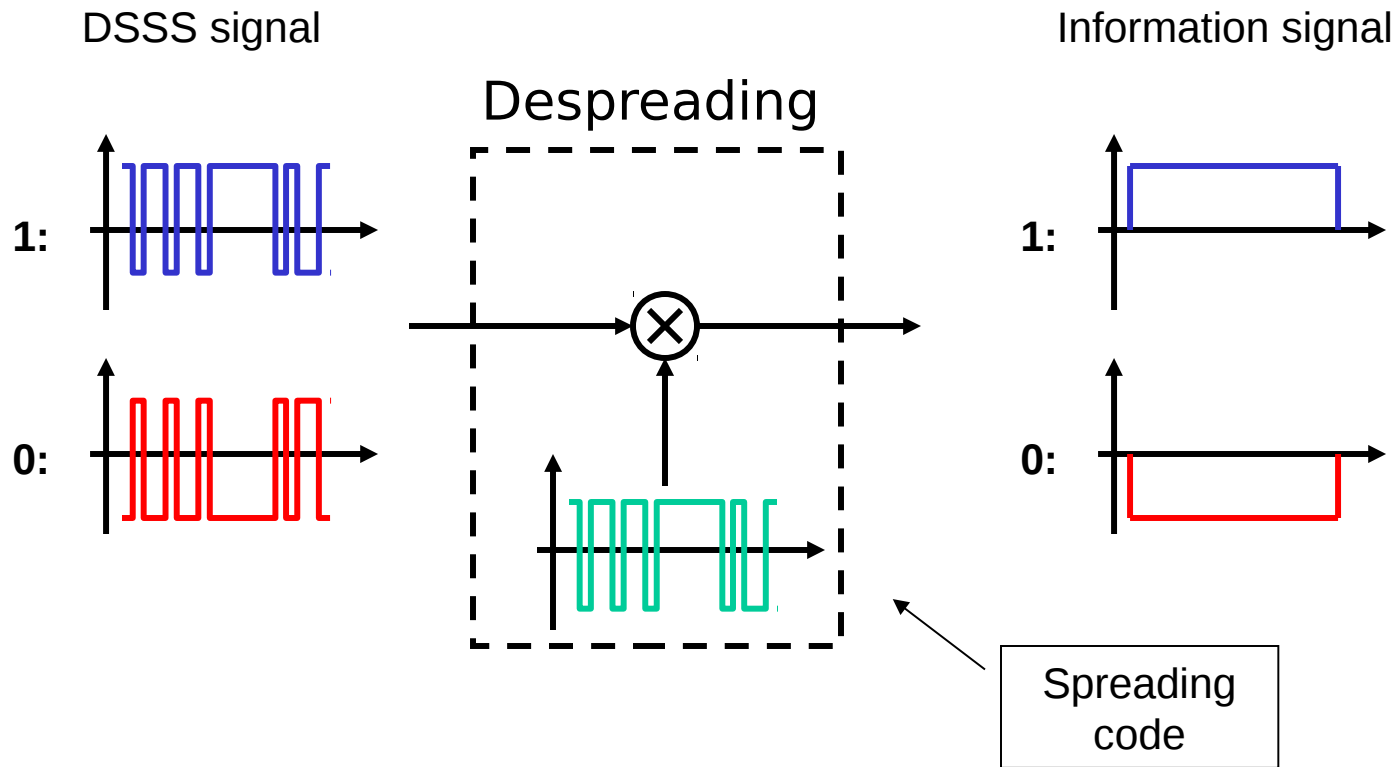

# Direct-Sequence Spread Spectrum DSSS



Spreading increases the bandwidth by a factor

$$M = \frac{T_b}{T_c}$$

where  $T_b$  is the bit time and  $T_c$  the spreading code chip time.

When despreading (with the correct code), we gain a factor  $G_p$  in power spectral density over other signals within the bandwidth.

The **processing gain**  $G_p$  is *at most*  $M$  and is determined by the **auto-correlation** properties of the spreading code.

# Direct-Sequence Spread Spectrum DSSS



If we want to exploit the multi-path channel, the despreading becomes a bit more complicated ...

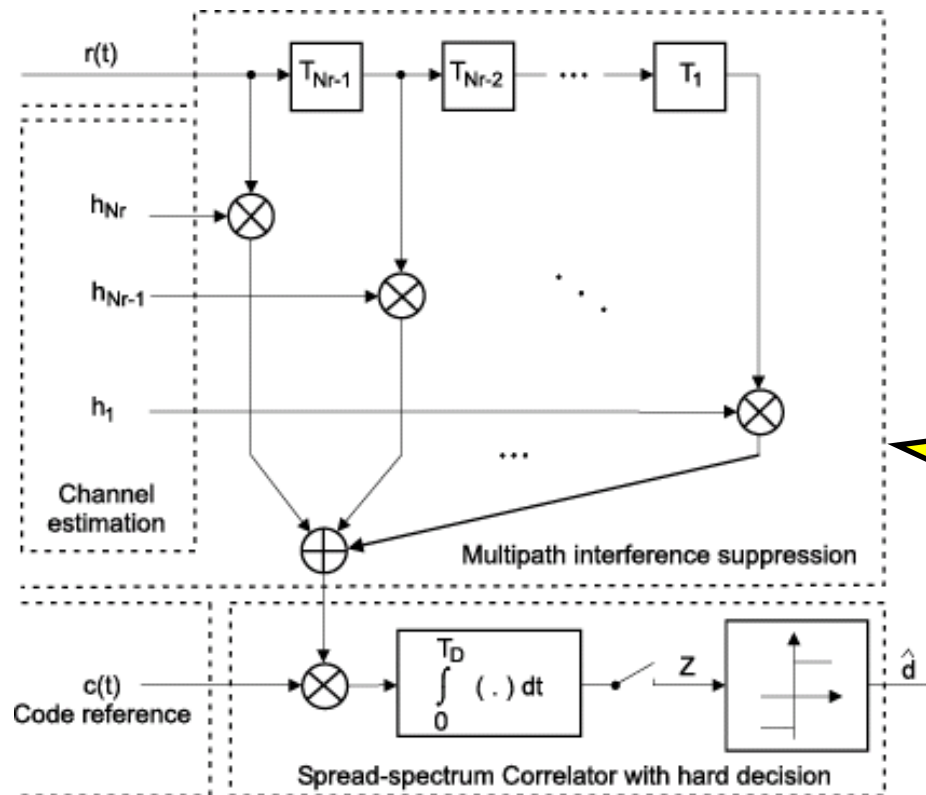

This structure is called a **rake** receiver.

... but we gain frequency diversity.

# Code-division multiple access (CDMA)

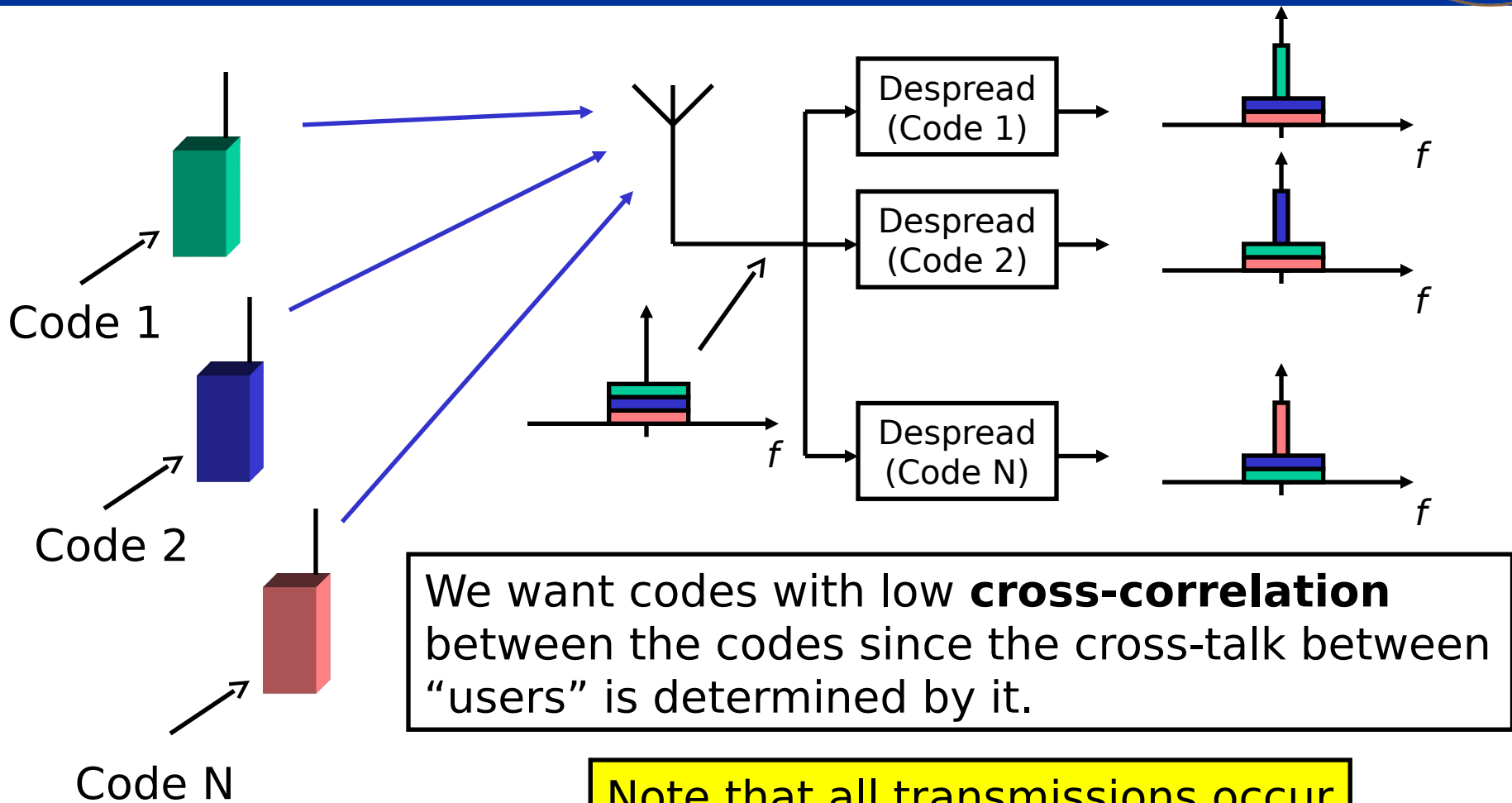

# Code-division multiple access (CDMA)



The **jamming gain** ( $J/C$ ) tells us how much stronger a jamming signal can be, compared to the wanted signal:

$$\left(\frac{J}{C}\right)_{\text{dB}} = G_{p|\text{dB}} - \left(\frac{E_b}{N_0}\right)_{\text{dB}}$$

This expression gives us a simple way of calculating how many users we can have in our system, if we regard the other users as jammers.

## QUICK EXAMPLE:

Assuming a spreading factor  $M=512$  and an optimal processing gain of  $G_p=M$ , and a required  $(E_b/N_0)$  of 10 dB for proper reception, we get

$$\left(\frac{J}{C}\right)_{\text{dB}} = 10 \log_{10} 512 - 10 = 17.1 \text{ dB} = 51.2$$

Hence, we can have 51 other users (with their own spreading codes and equal power) in our system.

# Code-division multiple access (CDMA)



The jamming margin gives us a conservative measure on the number of users, since it assumes that we do not use any advanced detection scheme ... only despreading of each user and detection.

Since a base-station has knowledge about the spreading codes of all users in a cell, it can detect all users jointly and thereby perform **interference cancellation**. This is called **multi-user detection** and requires high processing power of the base station.

# Code-division multiple access (CDMA)



Since users in a cell are separated by codes, and transmit simultaneously in the same frequency band, we can use the same frequency band in all cells in a cellular system.

An advantage of CDMA is that the establishment of new “channels” can be done as long as the interference is kept below a certain level. This gives a flexibility which we do not have in FDMA and TDMA.

Another advantage of CDMA is that we can establish channels with different spreading factors, allowing different data rates.



# Summary

- The available radio resource is shared among users in a **multiple access** scheme.
- When we apply a **cellular structure**, we can **reuse** the same channel again after a certain distance.
- In cellular systems the limiting factor is **interference**.
- For FDMA and TDMA the tolerance against interference determines the possible **cluster size** and thereby the amount of resources available in each cell.
- For CDMA systems, we use **cluster size one**, and the number of users depends on **code properties** and the capacity to perform **interference cancellation (multi-user detection)**.