



LUNDS UNIVERSITET

Lunds Tekniska Högskola

Electrical and Information Technology

Göran Jönsson

2017-05-11

Microwave Theory

ETENØ1

Laboratory Experiment

2017

1 Introduction

The network analyser is one of the most important instruments for high frequency measurements. In these experiments, you will become familiar with the basic operation of the instrument. Note that the network analyser is a far more versatile instrument than what you will experience here.

The following experiments will be performed:

- Calibration of the network analyser.
- Measurement of the black box containing unknown components.
- Measurement of the characteristic impedance of a microstrip line.

2 Experiments

Here you will become familiar with the basic operation of network analysers including calibration procedures and S-parameter measurements.

2.1 Setting up the Network Analyzer

Prior to calibration the instrument must be set up to the desired frequency range, the output power, the number of points to be measured over the frequency range etc.

To speed up the setup of the instrument follow the instructions below:

1. Since you do not have knowledge of who has used the instrument before you and what settings they might have selected it is a good advice to set the instrument to the default factory settings:

STATUS: PRESET x 1

2. Choose the frequency range of the built-in signal generator:

STIMULUS:START > 10 M

STIMULUS:STOP > 1 G

3. Set the output power of port 1 and port 2 to -10 dBm:

SWEEP: SOURCE > POWER -10 x 1

4. Choose the number of points to be measured over the frequency range:

SWEEP: SWEEP > LIN SWEEP NUMBER OF POINTS > 401

5. Four different logic channels (CH1, CH2, CH3, CH4) will be used to measure the four S-parameters (S_{11} , S_{21} , S_{12} , S_{22}). To make sure that the calibration procedure applies to all four logic channels all channels should be coupled:

SWEEP: SWEEP > COUPLED CHANNEL

Note: the button should light green when selected!

6. Display all four channels:

RESPONSE: DISPLAY > QUAD CHAN, QUAD SPLIT

2.2 Calibration

Contributions from cables should not be part of the measurement. That is, prior to the actual measurements the analyser must be calibrated to shift the measurement reference plane. By having the cables terminated by a set of standards; **Open**, **Short**, **Match** and **Through**, everything between these terminations and the instrument can be cancelled by performing a calibration.

To calibrate the instrument, follow the instructions below:

CAL: CAL > START NEW CAL >

FULL TWO PORT > PC7 > TOSM

Connect the respective standard to the cable and push the button corresponding to the standard. When you are finished with all four standards do not forget to push the APPLY CAL button.

2.3 Measurement of the Black Box

The black box contains unknown components. Your objective is to try and figure out what might be connected to the respective port of the box by using your knowledge of the behavior of transmission lines and real passive components. There is a connection between ports two and five.

If you have found any transmission lines, calculate the physical length of them if the phase velocity is $v_p = 0.7c$. (Hint: measure the first resonance frequency.)

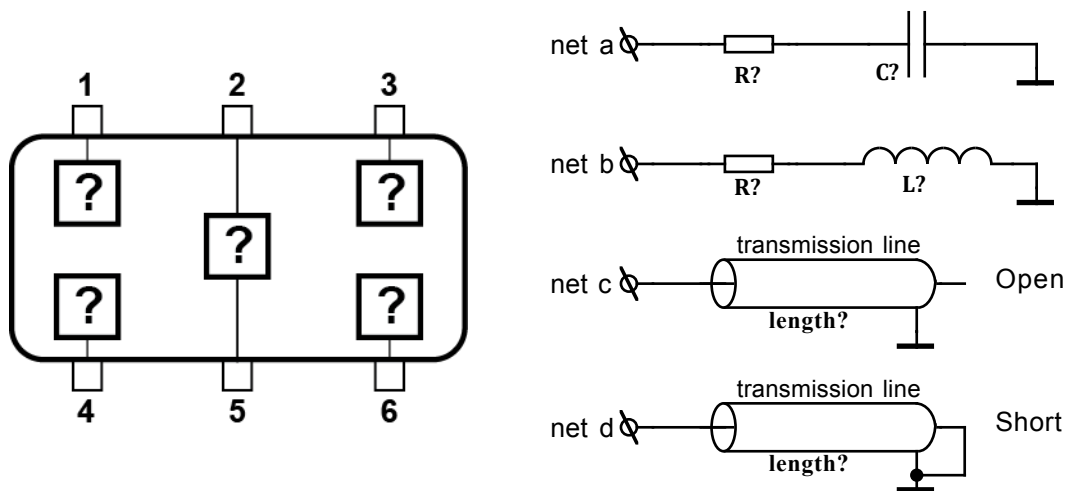

Figure 1: The Black Box.

2.4 Measurement of the characteristic impedance

The printed circuit board (pcb) contains three microstrip lines of equal length. One line is terminated by a short circuit, the second line is terminated by an open circuit and the third line is terminated by a 51Ω resistance. Measure the first resonance frequency of the open and short-circuited lines and discuss why there is a moderate discrepancy.

Please note that you cannot measure the characteristic impedance directly, but you can measure the input impedance Z_{in} . For a no loss line the input impedance is given by

$$Z_{in} = Z_0 \frac{Z_L + jZ_0 \tan \beta \ell}{Z_0 + jZ_L \tan \beta \ell} \quad \text{where} \quad \beta = \frac{2\pi}{\lambda}$$

Hint: Try to find a smart frequency where measure the input impedance and you can easily solve the problem almost without the calculator!