

Övning 1
EITF25 & EITF45 - 2016
Kodning och multiplexering

November 8, 2016



LUNDS UNIVERSITET
Lunds Tekniska Högskola

Uppgift 1.

Vad blir bithastigheten för följande signaler?

- 1.1 En signal där en bit varar i 1 millisekund?
- 1.2 En signal där en bit varar i 2 microsekunder?

Solution 1.

- 1.1 If a bit occupies 1 millisecond = 10^{-3} seconds, then a second is occupied by $\frac{1}{10^{-3}} = 10^3$ bits = 1 kbps.

Answer: 1 kbps

- 1.2 If a bit occupies 2 microseconds = 2×10^{-6} seconds, then a second is occupied by $\frac{1}{2 \times 10^{-6}} = 0.5 \times 10^6$ bits = 500 kbps.

Answer: 500 kbps

Uppgift 2.

Hur länge varar en bit i följande signaler?

- 2.1 En signal med bithastighet 100 kbps?
- 2.2 En signal med bithastighet 2 Mbps?

Solution 2.

- 2.1 If bits are produced/received at a rate of $100 \times 10^3 = 10^5$ per second, then one bit occupies $\frac{1}{10^5} = 10^{-5}$ seconds = 10 microseconds.

Answer: 10 microseconds

- 2.2 If bits are produced/received at a rate of 2×10^6 per second, then one bit occupies $\frac{1}{2 \times 10^6} = 0.5 \times 10^{-6}$ seconds = 0.5 microseconds.

Answer: 0.5 microseconds

Uppgift 3.

Antag att vi ska skicka en bitsekvens som består av 10 nollor. Koda sekvensen med följande linjekodningstekniker:

- 3.1 NRZ
- 3.2 Manchester
- 3.3 Differential Manchester

Solution 3.

- 3.1 In a NRZ (Non-Return-to-Zero) modulated transmission ones and zeros are represented by a specific output level, constrained to a specified duration.

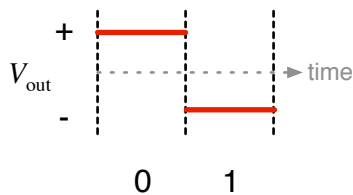

As a consequence, unless you know when the transmission started and the duration a bit occupies, you will be unable to distinguish between multiple consecutive bits of the same sign. In a communication system, both receiver and transmitter thus need to be synchronized.

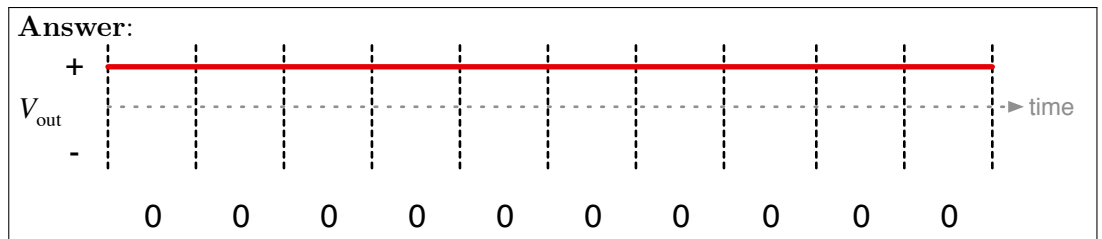

- 3.2 In a Manchester modulated signal, each bit i demarked by an output transition during the allocated bit duration (symbol) as opposed to a constant level seen in NRZ modulation. In the figure below a zero is represented by a falling edge, while a one is represented by a rising edge.

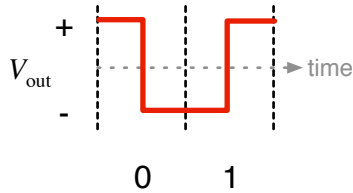

As each bit infers a output level transition, with Manchester coding, each bit can be identified without prior clock synchronization. Nevertheless, both receiver and transmitter needs to agree on which transition to represent which bit. Moreover, In this case, we are dealing with a sequence of all zeros, the signal is thus modulated with all falling edges for each bit. Manchester coding has a relative low throughput compared to more complex modulation schemes and is today mainly used in systems such as 10BASE-T ethernet (IEEE 802.3) and NFC.

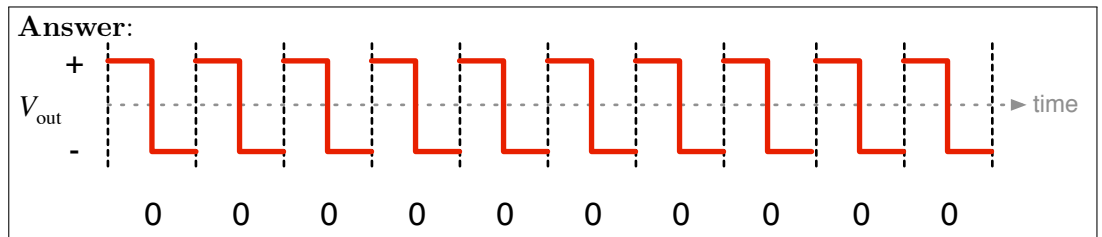

- 3.3 As you will see in Problem 5, Differential Manchester coding deals with transitions between symbols rather than output levels within a symbol. A sequence with all zeros is represented by the absence of symbol transitions, and the waveform is therefore identical to the Manchester coded one in problem 3b.

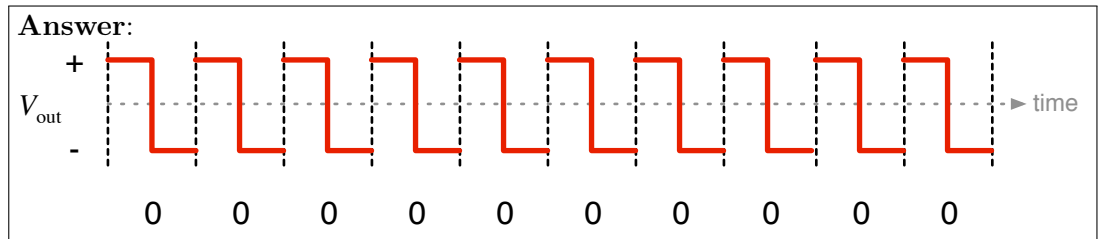

Uppgift 4.

Vågformen i nedanstående bilder är Manchesterkodade binära sekvenser. Avkoda dem!

4.1

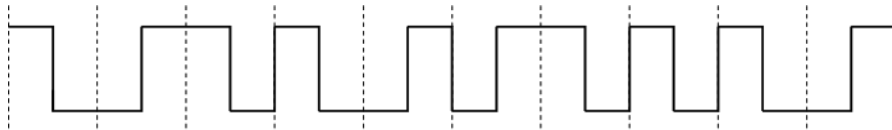

4.2

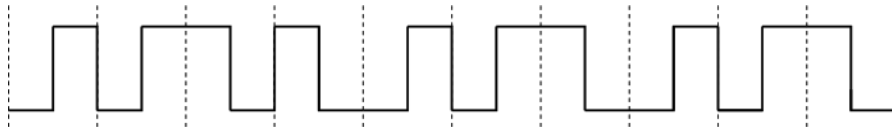

4.3

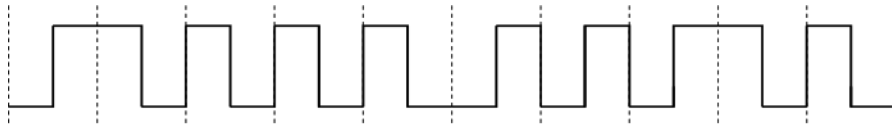

Solution 4.

When applying the Manchester modulation scheme presented in Solution 3.2 to the observed sequence, we arrive at the bit sequence presented in Solutions 4.1, 4.2, and 4.3.

4.1 Following the above convention yields.

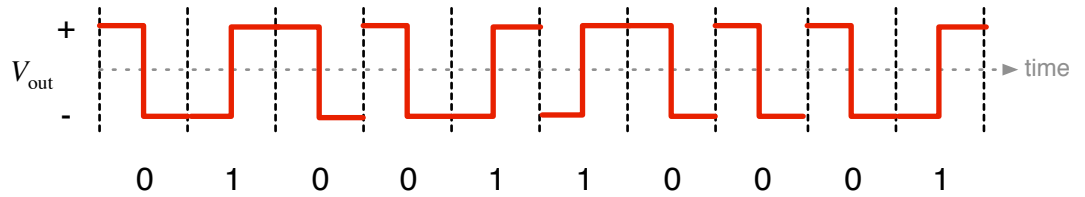

Answer: 0100110001

4.2 Following the above convention yields.

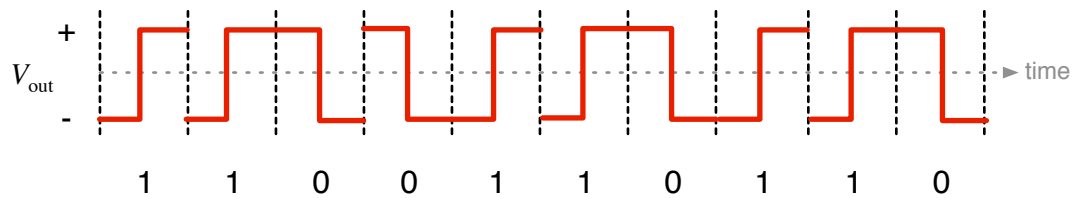

Answer: 1100110110

4.3 Following the above convention yields.

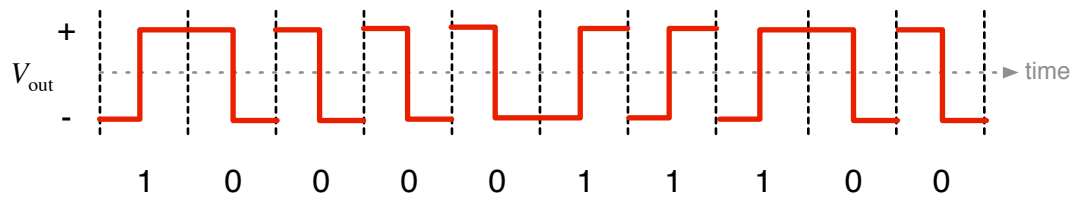

Answer: 100011100

Uppgift 5.

Gör om avkodningen i Uppgift 4 om bitsekvenserna istället är kodade med Differential Manchester!

Solution 5.

As opposed to Manchester coding, Differential Manchester coding only represents transitions between 0 → 1.

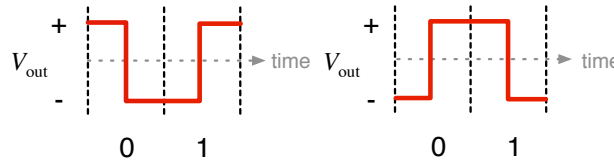

As such, several transitions represent just as many ones. A single transition followed by a consecutively repeated symbol represents a one followed by zeros, until the next transition. As such, the absence of a transition signifies a zero.

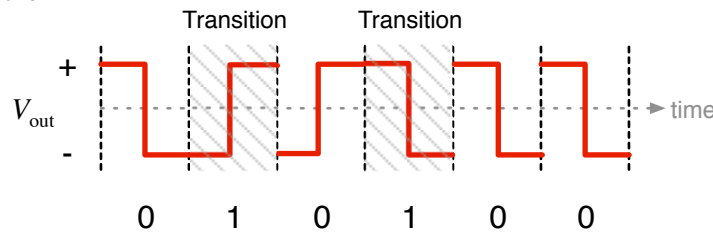

When observing an arbitrary waveform, as we do not know whether it is a continuation of the previous symbol or a transition, the first bit is inherently unknown.

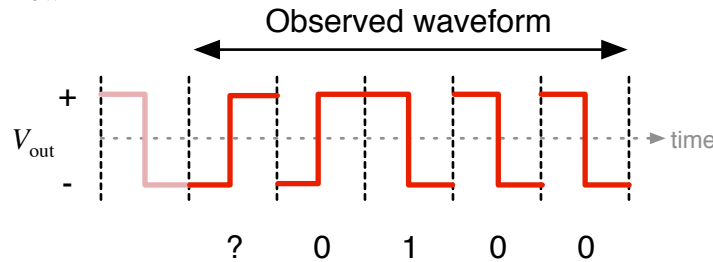

As you can see in the figure above, we do not know if first symbol is zero that transitions into a one, or the tail of a sequence of transitions representing several ones. Differential Manchester is used because a transition is less likely to be misinterpreted than a individual symbols by the receiver, given a noisy channel. Differential Manchester encoding is predominantly used in magnetic and optical storage.

5.1 Following the above convention yields.

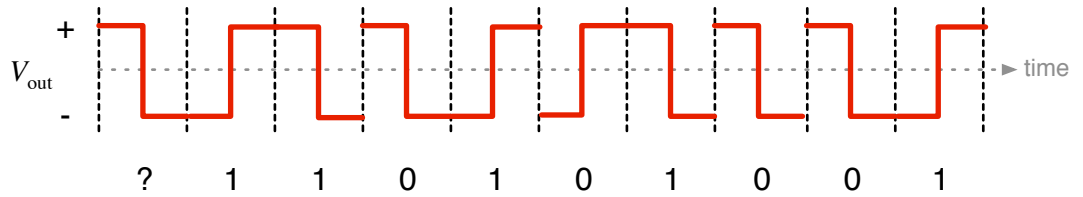

Answer: 110101001

5.2 Following the above convention yields.

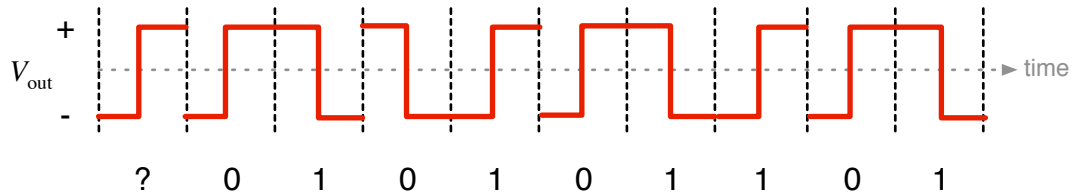

Answer: 010101101

5.3 Following the above convention yields.

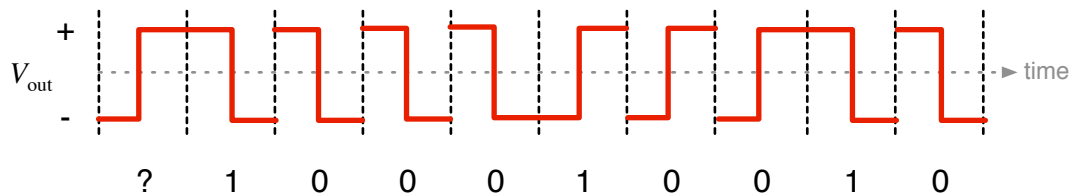

Answer: 100010010

Uppgift 6.

Antag att vi ska skicka den binära sekvensen 0101110.

6.1 Skissa vågformen om Manchesterkodning används.

6.2 Skissa vågformen om Differential Manchesterkodning används.

Antag i båda fallen att den första signalen är en övergång från hög nivå till låg, oavsett om det är en datasignal eller klocksignal.

Solution 6.

6.1 Following the convention established in Problem 4.

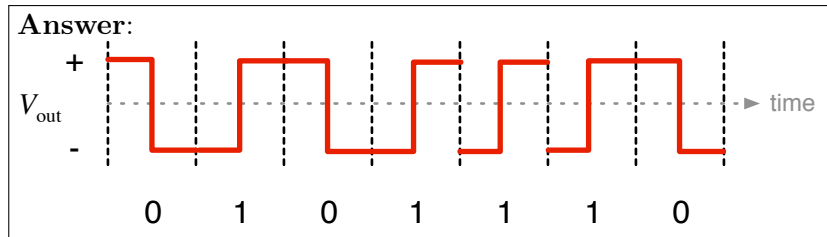

6.2 Following the convention established in Problem 5. The first symbol is to illustrate the state of the signal.

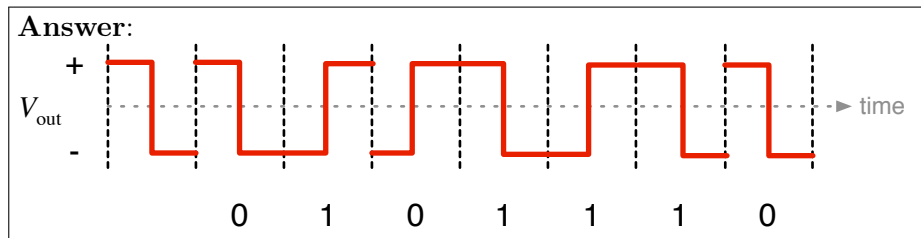

Uppgift 7.

En fysisk länk har fem förbindelser som multiplexeras med FDM. Varje förbindelse kräver en kanal med en bandbredd på 4 000 Hz. Mellan varje kanal måste 200 Hz finnas för att undvika interferens. Bestäm den minimala bandbredden för länken.

Solution 7.

Being it a wireless, an optical, or an electrical link, in FDM (Frequency Division Multiple access) the entire or a portion of that mediums frequency spectrum bandwidth is divided into channels, see the figure below. Moreover, this is one approach for accommodating multiple connections in a common link, where the transmitter (Tx) and receiver (Rx) are transmitting and receiving in the same allocated frequency range, channel. In most FDM based communication systems, a frequency guard interval is introduced to separate

the channels, see the figure below. This is to ensure that any leakage from one channel is not interfering with its adjacent channels. The guard interval does not carry any intentional information. Note that guard intervals are only needed to separate the channels in the medium, and not the channels from beyond the frequency range of the medium. Unless there is another communication link at a frequency range above or below, in which case, a guard interval is introduced between the links. However, this is not taken into account when referring the bandwidth of the observed link.

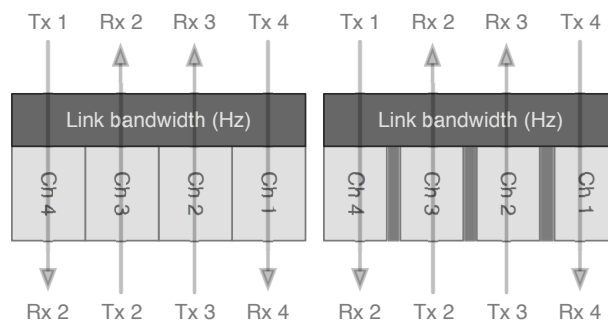

In this instance, it is specified that each channel needs a bandwidth of $4000 \text{ Hz} = 4 \text{ kHz}$ with a guard interval of $200 \text{ Hz} = 0.2 \text{ kHz}$. Since there are five channels, we need four guard intervals to separate them. Moreover, this leaves us with a total link bandwidth of $5 \times 4 \text{ kHz} + 4 \times 0.2 \text{ kHz} = 20.8 \text{ kHz}$. See the figure below.

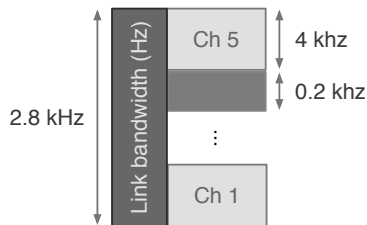

Answer: 20.8 kHz

Uppgift 8.

Antag att tre förbindelser frekvensmultiplexeras på en länk som har en total bandbredd på 7900 Hz. Vilken blir den maximala bandbredden per förbindelse, om det mellan varje kanal måste finnas ett outnyttjat frekvensband på 200 Hz?

Solution 8.

In this example we are allocated a total link bandwidth of $7900 \text{ Hz} = 7.9 \text{ kHz}$. It is specified that the link will carry 3 channels and that the channels shall be separated by unused frequency space, or guard intervals of $200 \text{ Hz} = 0.2 \text{ kHz}$ each. Since there are three channels, they will be separated by a total of 2 guard intervals. See the figure below.

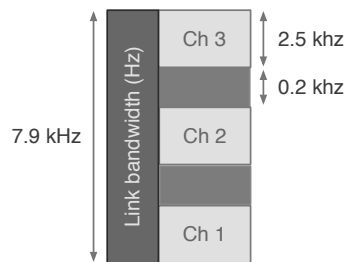

Subtracting the sum of the two guard intervals of 0.2 kHz each from the total allocated link bandwidth leaves us with the remaining bandwidth for the sum of the three channels, $7.9 \text{ kHz} - 2 \times 0.2 \text{ kHz} = 7.5 \text{ kHz}$. Furthermore, as there are three channels, each channel can be allowed a bandwidth of $\frac{7.5}{3} \text{ kHz} = 2.5 \text{ kHz}$.

Answer: 2.5 kHz

Uppgift 9.

Antag att 100 förbindelser är multiplexerade med TDM och varje förbindelse skickar $14,4 \text{ kbps}$.

- 9.1 Vilken är den minsta bithastighet som länken måste klara av (ignorera synkroniseringsbitar)?
- 9.2 Antag att endast 70 förbindelser skickar data samtidigt. Hur stor andel av bandbredden är utnyttjad?

Solution 9.

9.1 In a Synchronous TDM (Time Division Multiplexing) system, each sub-link is assigned a reoccurring time slot at a constant frequency on the multiplexed link. The capacity of the multiplexed link is shared proportionally amongst sub-links. For example, as illustrated in the figure below, if the main link has a capacity of 3 Mbit and is shared indiscriminately amongst the three sub-links, they will each a access to a throughput of 1 Mbps.

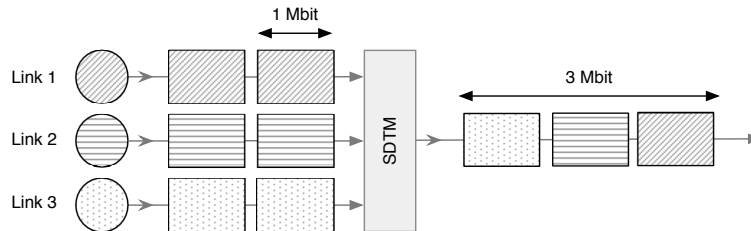

Furthermore, it is specified that each each of the 100 sub-links have a capacity of 14,4 kbps. In order to ensure that the each sub-links capacity is atleast maintained, the multiplexed link needs to have minimum capacity of $100 \times 14.4 \text{ kbps} = 1.44 \text{ Mbps}$.

Answer: 1.44 Mbps

9.2 In a Synchronous TDM system, unused time slots are left unused if a sub-link has nothing to transmit. See the figure below.

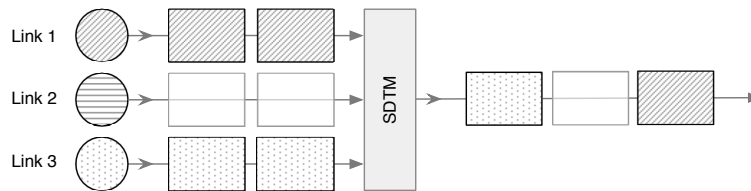

As such, if only 70 out of 100 sub-links have information to transmit, then 30 % of the congruent time slots are left unused.

Answer: 30%

Uppgift 10.

Antag att fyra förbindelser multiplexeras med TDM. I varje tidslucka får det plats ett ASCII-tecken. Vad kommer att skickas på länken om sändarna vill skicka följande tecken: sändare 1: T E G; sändare 2: A; sändare 3: C D; sändare 4: E F I L?

Solution 10.

It is given that each character occupies a time frame. Since the links carry different quantities of data, there will be vacant time slots. See the figure below.

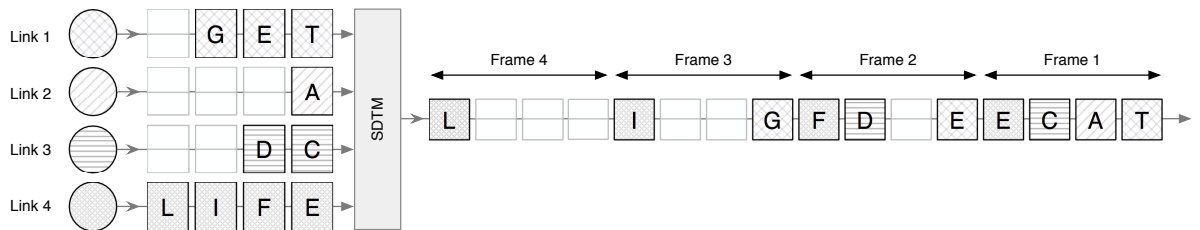

Assuming that the sender on each link starts to send their letters simultaneously, the first frame will contain the first letter transmitted on each link. The subsequent frame will contain the second letter, if any. Moreover, in this instance 6 out of 16 frames will go unused, resulting in a link utilization of $\frac{10}{16} = 62.5\%$.

Answer:

L					I			G	F	D		E	E	C	A	T
---	--	--	--	--	---	--	--	---	---	---	--	---	---	---	---	---

Uppgift 11.

Vad kommer att skickas på länken i Uppgift 10 om STDM (Statistical Time Division Multiplexing) används istället och alla förbindelser har samma prioritet?

Solution 11.

In a Statistical TDM system, the multiplex fills each subsequent and squall sized time slot with the next available frame from the buffer. In other words, if a sub-link has nothing to send in this time frame the multiplexer will try to fill that time slot with data from the next sub-link that has data to send in the multiplexers buffer. Consequently, this ensures that all slots are utilized, given that there is data to send. See the figure below.

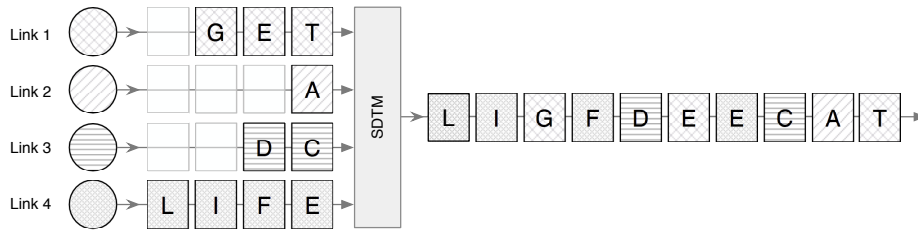

As such, compared to Synchronous TDM, Statistical TDM will not transmit the intermediate vacant time frames.

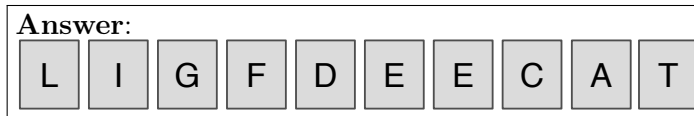

Uppgift 12.

Figuren nedan visar en multiplexor för STDm. Antag att en ram innehåller 3 tidsluckor, varje tidslucka rymmer 3 bitar och varje ram börjar med en synkroniseringsbit (alternierande mellan 0 och 1). Svara på följande frågor:

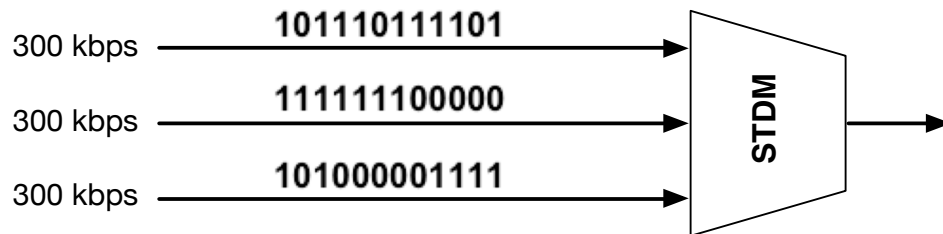

- 12.1 Hur blir bitströmmen ut från multiplexorn?
- 12.2 Vad är bithastigheten på den utgående länken?
- 12.3 Hur lång tid varar en bit på den utgående länken?
- 12.4 Hur många ramar skickas per sekund?
- 12.5 Hur lång tid varar varje ram?

Solution 12.

The described Synchronous TDM system combines three sub-links of 300 kbps each. A frame starts with a synchronization bit, followed by three time slots of 3 bits each, resulting in a frame size of 10 bits. See the figure below.

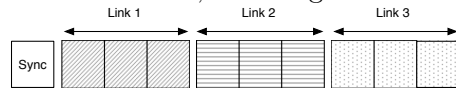

12.1 The three streams are congruent, as a result there are no vacant time slots in the resulting Synchronous TDM transmission. When applying the frame structure in the figure below to the specified bit streams, assuming that the first sync bit is 0, the resulting first frame will have the following content:

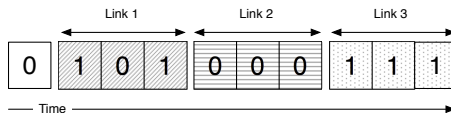

As you can see the time slot is occupied by the first 3 bits from Link 1, followed by three consecutive bits each from Link 2 and Link 3 respectively. The following frame will start with the sync bit set to 1, prefixed to the following three consecutive bits from each Link.

Answer:

1	0	1	1	1	1	1	0	1	1	0	0	0	1	1	1	1	1	0	0	0	1	1	0	0	1	1	0	0	1	1	1	1	1	1	0	0	0	1	0	1	0
---	---	---	---	---	---	---	---	---	---	---	---	---	---	---	---	---	---	---	---	---	---	---	---	---	---	---	---	---	---	---	---	---	---	---	---	---	---	---	---	---	---

12.2 It is specified that each sub-link has a capacity of 300 kbps, as such the multiplexed link should have a capacity of at least $3 \times 300 \text{ kbps} = 900 \text{ kbps}$. However, the sync bit in each multiplexed frame of 9 data bits add one bit of overhead. As a result instead of sending 9 bits we are now sending 10 bits per frame. The link thus needs $\frac{10}{9} \approx 11\%$ extra capacity in addition to what is expected of the sub-links to maintain the oncoming traffic from the sub-links and to accommodate the sync bit. Moreover, applying the additional capacity needed to the minimum multiplex link capacity yields, $\frac{10}{9} \times 900 \text{ kbps} = 1000 \text{ kbps} = 1 \text{ Mbps}$.

Answer: 1 Mbps

12.3 In Solution 12.2 we concluded that the multiplexed link needs to have a minimum bandwidth of 1Mbps. Furthermore, each one of the bits transmitted on the multiplex link would have to occupy at least $\frac{1}{10^6} = 10^{-6}$ seconds = 1 microsecond.

Answer: 1 microsecond

12.4 Using what we deduced in Solution 12.3, if one bit occupies 1 microsecond, then a frame of 10 bits will occupy 10 microseconds. Consequently, one second is occupied by $\frac{1}{10 \times 10^{-6}} = 10^5 = 100000$ frames.

Answer: 100 000

12.5 As deduced in Solution 12.4, if one bit occupies 1 microsecond, then a frame of 10 bits occupy 10 microseconds.

Answer: 10 microseconds

Uppgift 13.

Figuren nedan visar en demultiplexor for STDm. Antag att en ram innehåller 3 tidsluckor, varje tidslucka rymmer 4 bitar och att inga synkroniseringsbitar används. Svara på följande frågor:

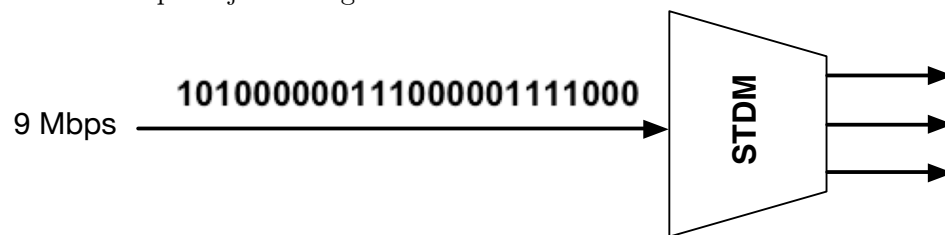

13.1 Vad blir bitströmmarna ut från demultiplexorn?

13.2 Vad är bithastigheten för varje utgående länk?

Solution 13.

13.1 The observed bit stream consists of 24 bits and can thus be broken down into 2 frames, each consisting of 3 time slots carrying 4 bits each. See the figure below.

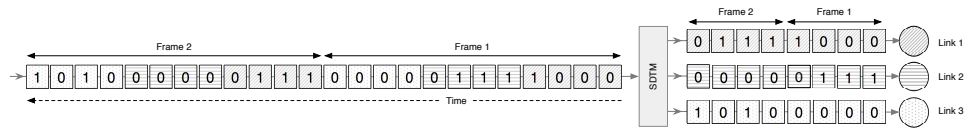

As there are no synchronizations bits in the stream, each frame can trivially be broken down and separated into each sub-links time slots and then reassembled, as illustrated in the figure above.

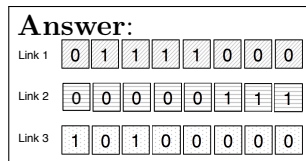

13.2 The main line is demultiplexed into three congruent sub streams. The specified frame only carries data, we can thus conclude that each resulting sub-link is is feed data at a rate of $\frac{9}{3} = 3$ Mbps.

Answer: 3 Mbps

Uppgift 14.

(Tenta - 2014-10-29)

- 14.1 Det finns både likheter och olikheter mellan IEEE 802.11 (WLAN) och accessnäten i mobiltelefonisystem (GSM, UMTS, LTE). Beskriv minst tre av dessa likheter och/eller olikheter.
- 14.2 Beskriv kortfattat en medium accessmetod som bygger på "controlled access".
- 14.3 Internet bygger på begreppet "internetworking". Förklara vad det innebär.
- 14.4 Förklara skillnaden mellan MAC-adresser, IP-adresser och port-adresser (nummer).