

ETS052

Internet Routing

Jens A Andersson



Routing

- The Routing Concept
- Unicast Routing
- Multicast Routing (short overview)

Network Layer (Layer 3)

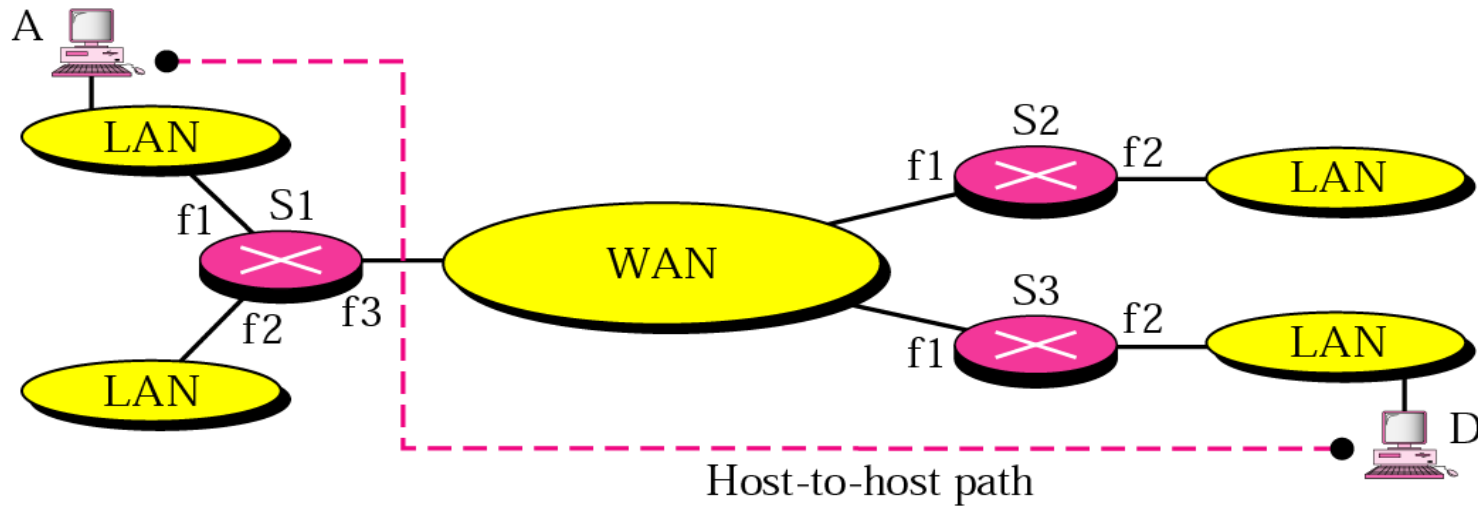
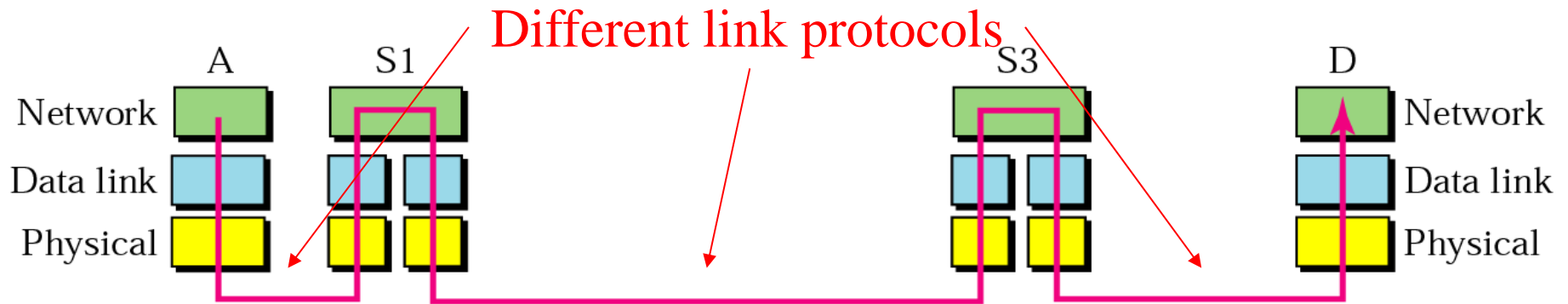

Datagrams in the network

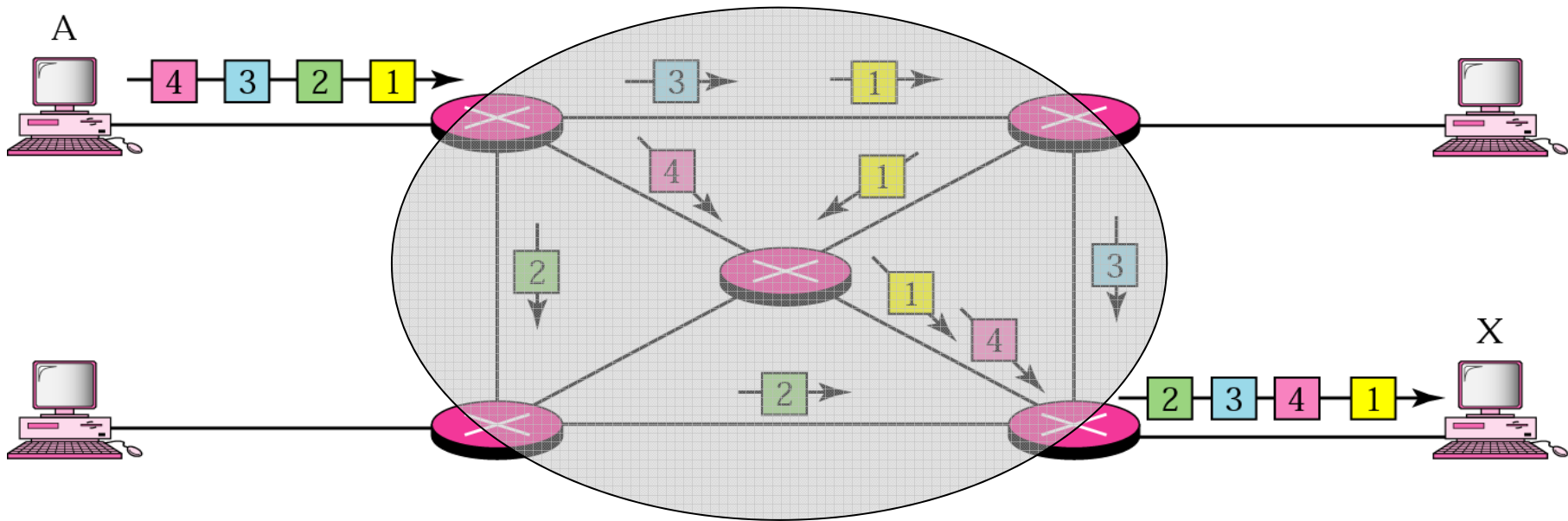

Task: Select Best Path

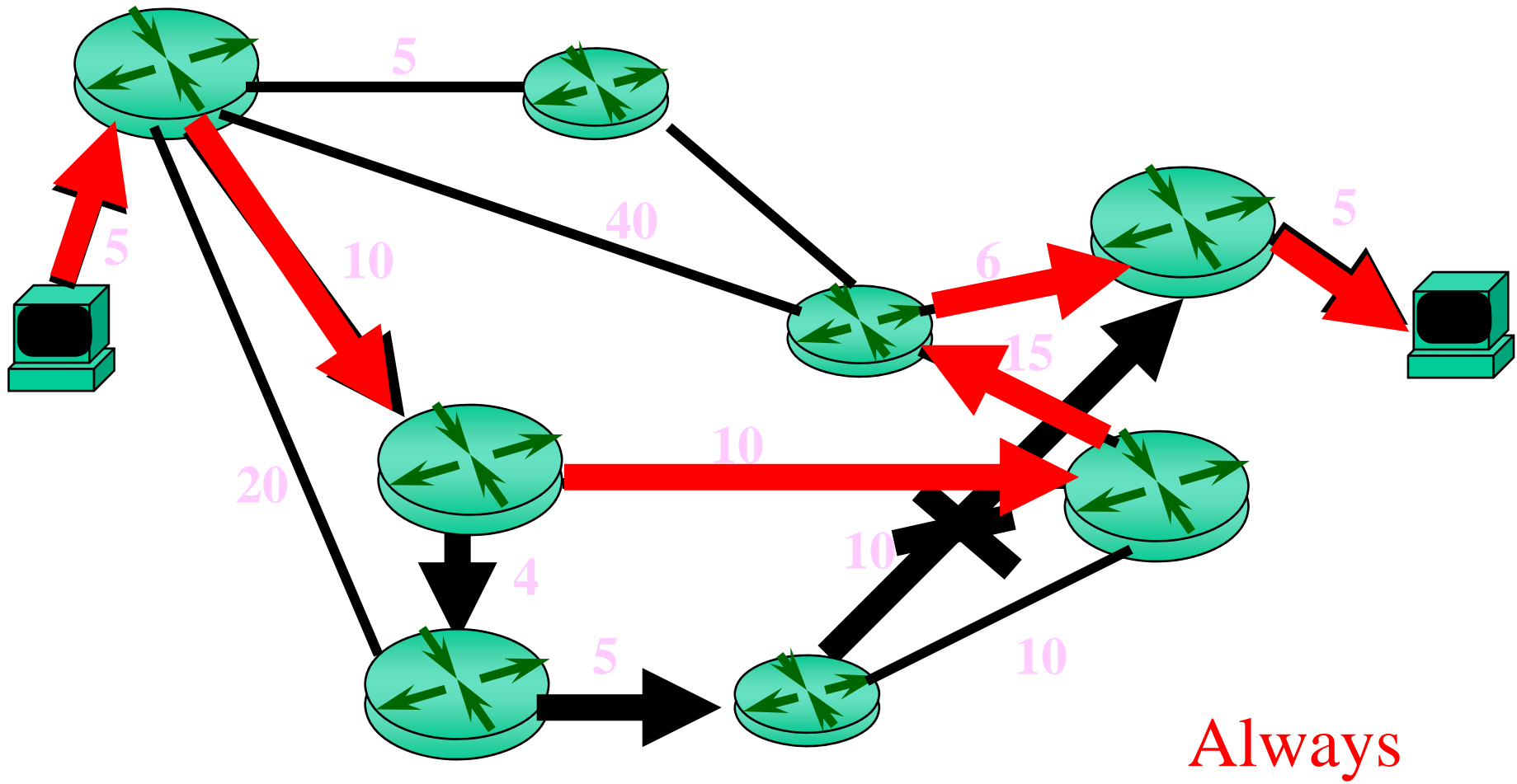

Router

- A router is a type of internetworking device that passes data packets between networks, based on Layer 3 or Network Layer addresses.
- A router has the ability to make intelligent decisions regarding the best path for delivery of data on the network.
- Routing is performed based on network identities, not host identities
 - Last step (delivery to host) performed with ARP

Router, schematiskt

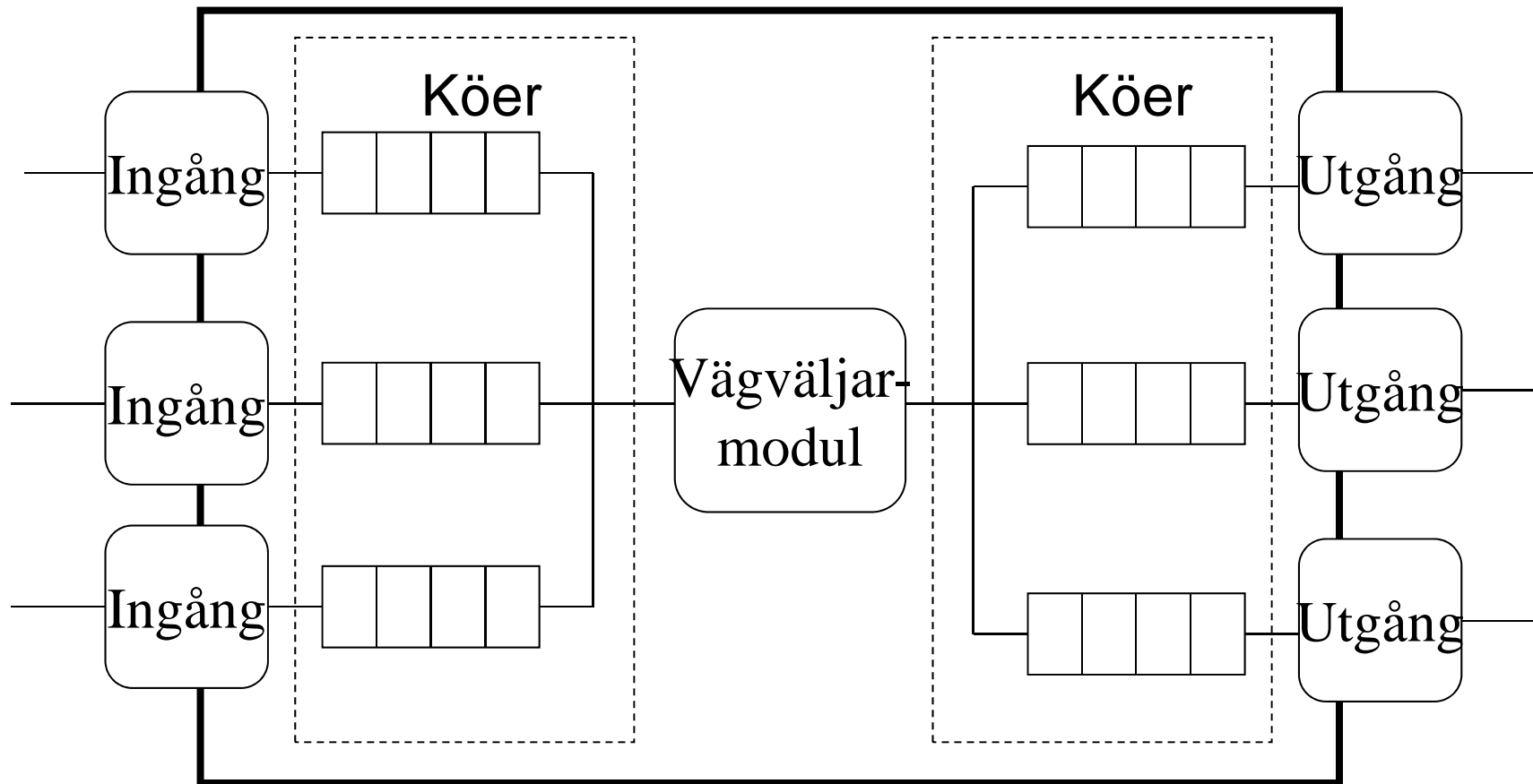

Schematic View of a Router

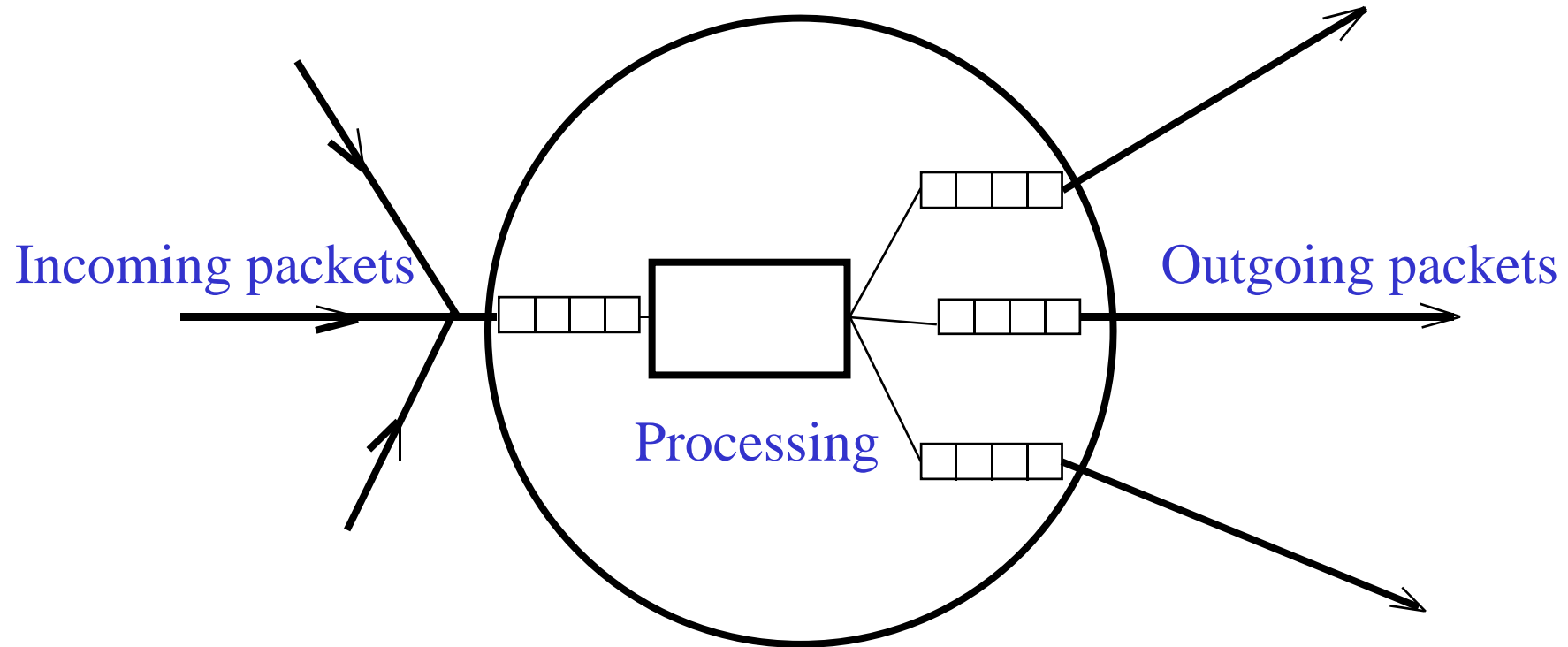

Routing Technologies

- No “intelligence”
- Centralized
- Distributed

No “intelligence”: Flooding

- Output all packets/datagrams
 - On all ports/interfaces/links
 - Except ingress port/interface/link
- Problem?
 - Looping packets
 - Two solutions
 - Avoided with TTL counter
 - Remember processed datagrams

Centralized routing technology

- Database and algorithm centralized
 - Network equipment informs central function
- Packet forwarding distributed
 - of course!?

Distributed routing technology

- Routing process distributed among all routers
- Two approaches
 - Distance Vector
 - Each nodes best-path information is distributed to its neighbours
 - Best end-to-end paths found from comparison of all next-hop choices
 - Simple, low demands on processor and memory
 - Link State
 - Local topology information is flooded to all nodes
 - Best end-to-end paths are computed locally at each router
 - More complicated, high demands on processor and memory

Path Cost, Link Metric

- Possible metrics
 - hop count
 - inverse of the link bandwidth
 - delay
 - dynamically calculated
 - administratively assigned
 - combination

Routing Tables and Forwarding Table

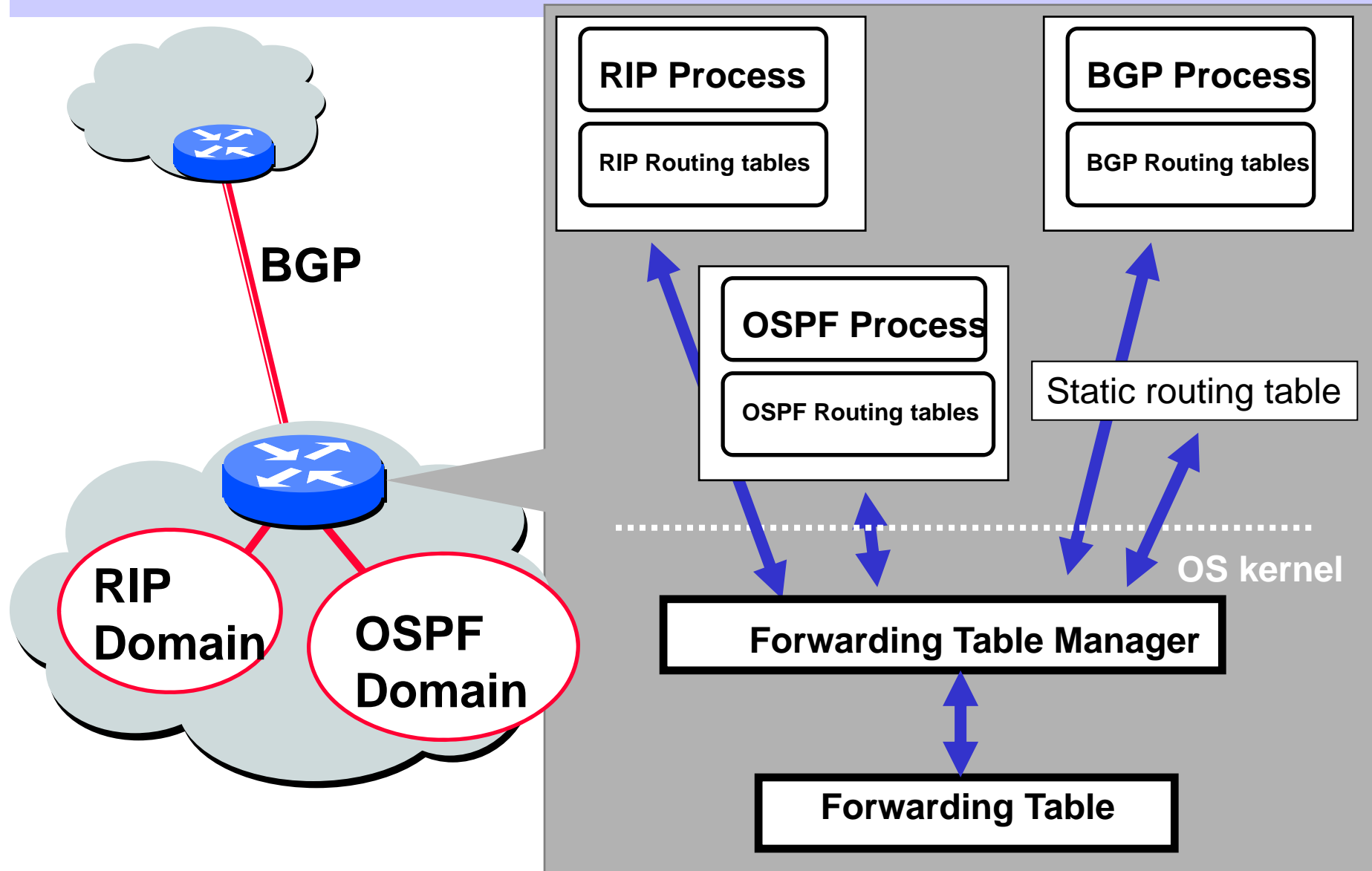

Local routing & ARP (1)

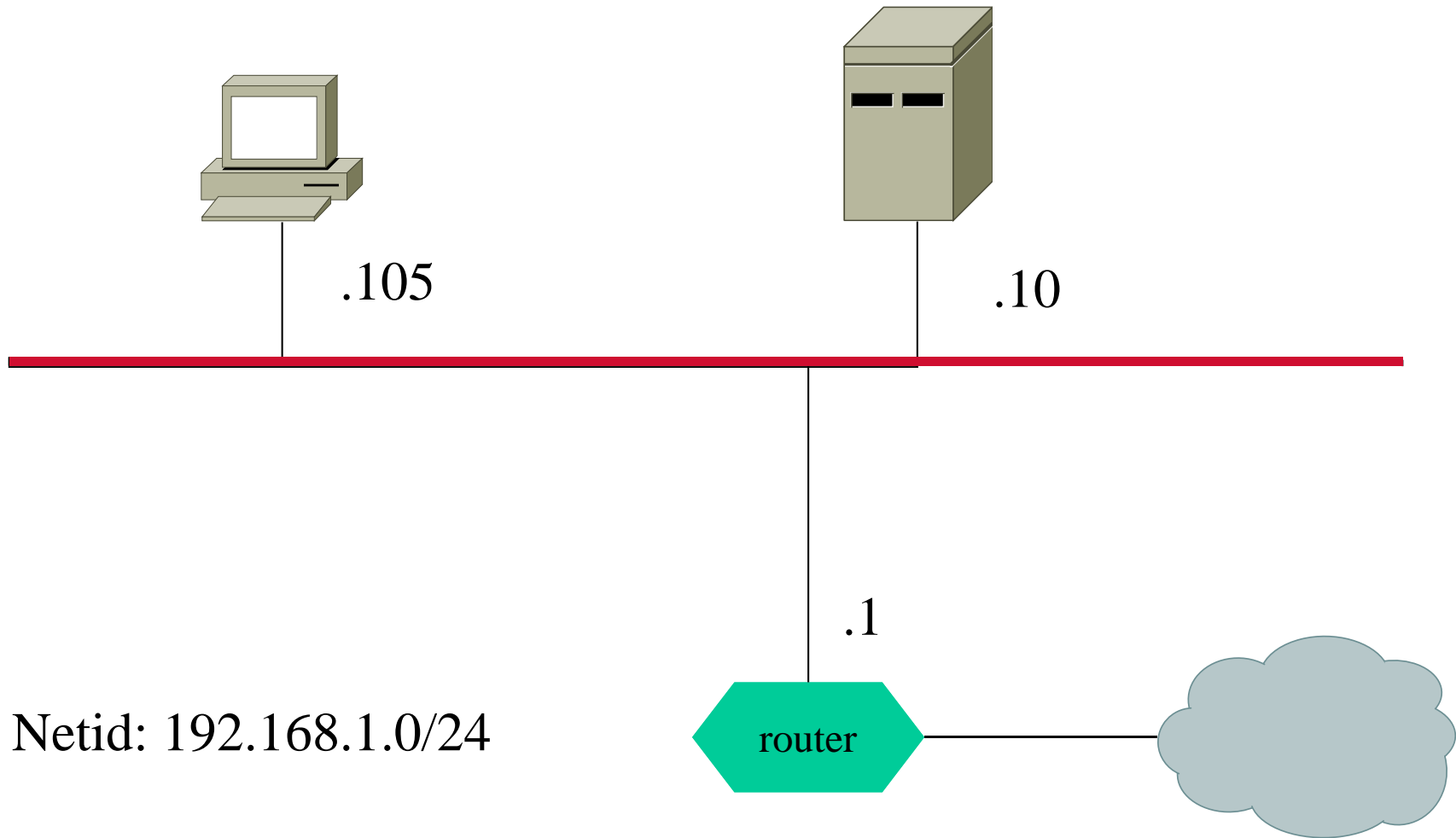

Local Routing & ARP (2)

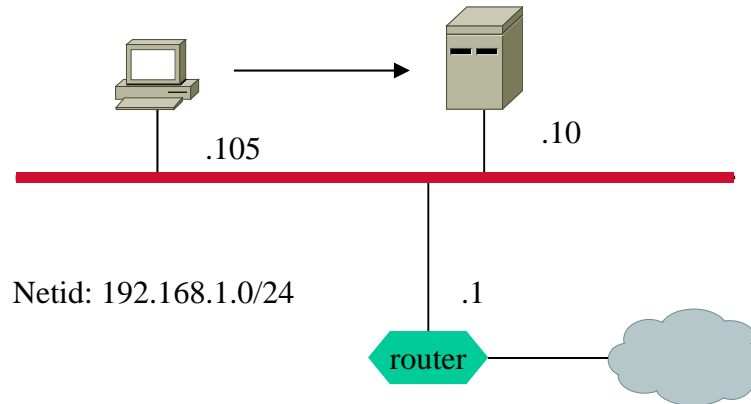

Send datagram to 192.168.1.10!

Is destination on same subnet?

Sender compares own net-id with net-id of destination.

in this case YES

Is MAC-address of destination in ARP-cache?

if YES, use it

if NO, use ARP

Local Routing & ARP (3)

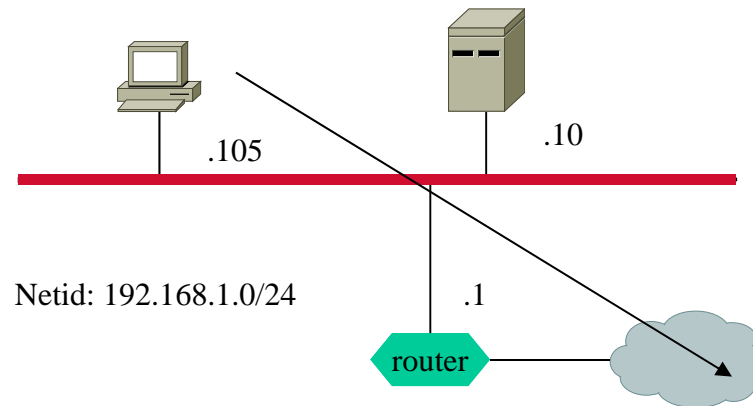

Send datagram to 10.0.100.35!

Is destination on same subnet?

Sender compares own net-id with net-id of destination.

in this case NO

Is network address of default gateway known?

If YES, is MAC-address of default gateway in ARP-cache?

if YES, use it

if NO, use ARP

Unicast Routing

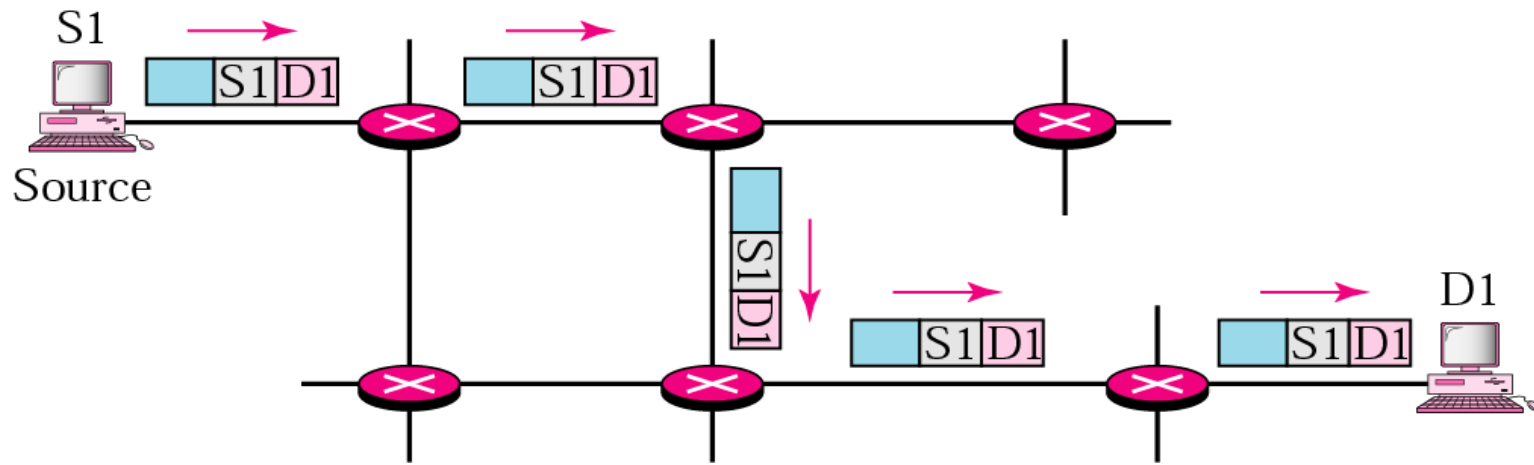

Routable protocols

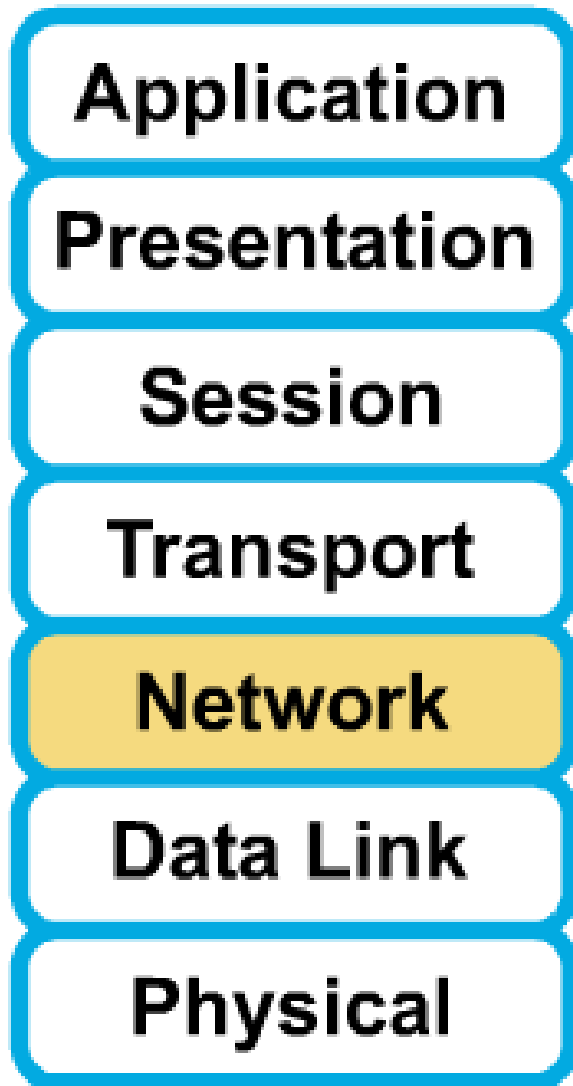

- Protocols that provide support for the network layer are called **routed** or **routable protocols**.
- IP is a network layer protocol, and because of that, it can be routed over an internetwork.

Routing protocols

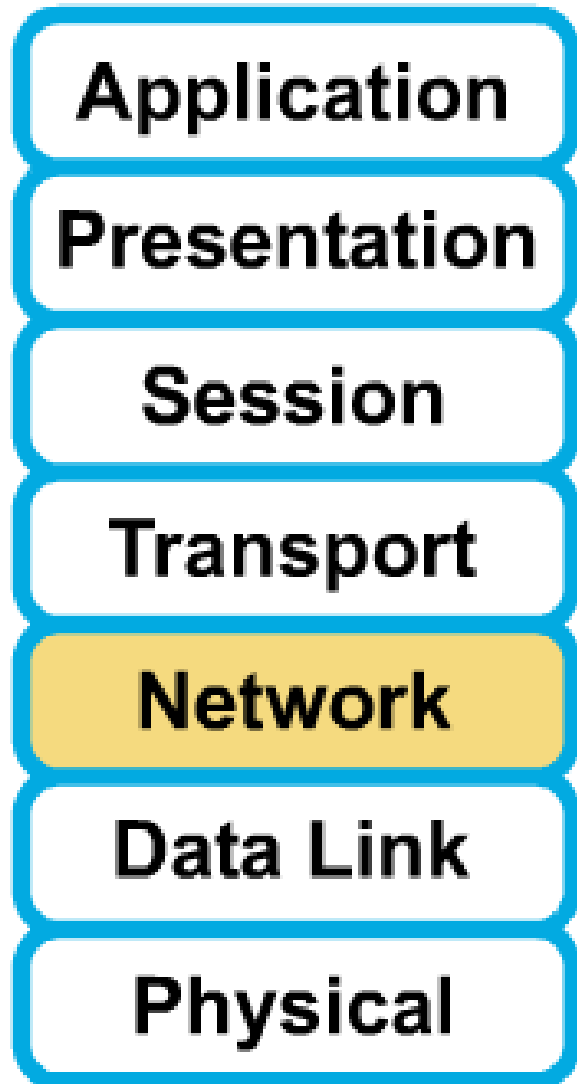

- **Routing** protocols determine the paths that routed protocols follow to their destinations.
- Routing protocols enable routers that are connected to create a map, internally, of other routers in the network.

Routing

- The art of building least-cost trees
 - From sender to receiver
 - From each node to every other node
- Three principles
 - Distance Vector
 - Link State
 - Path Vector
 - Policy-based routing

A distance vector

Net-id	Cost
-	-
-	-
-	-
-	-
-	-

Distance Vector: Principle

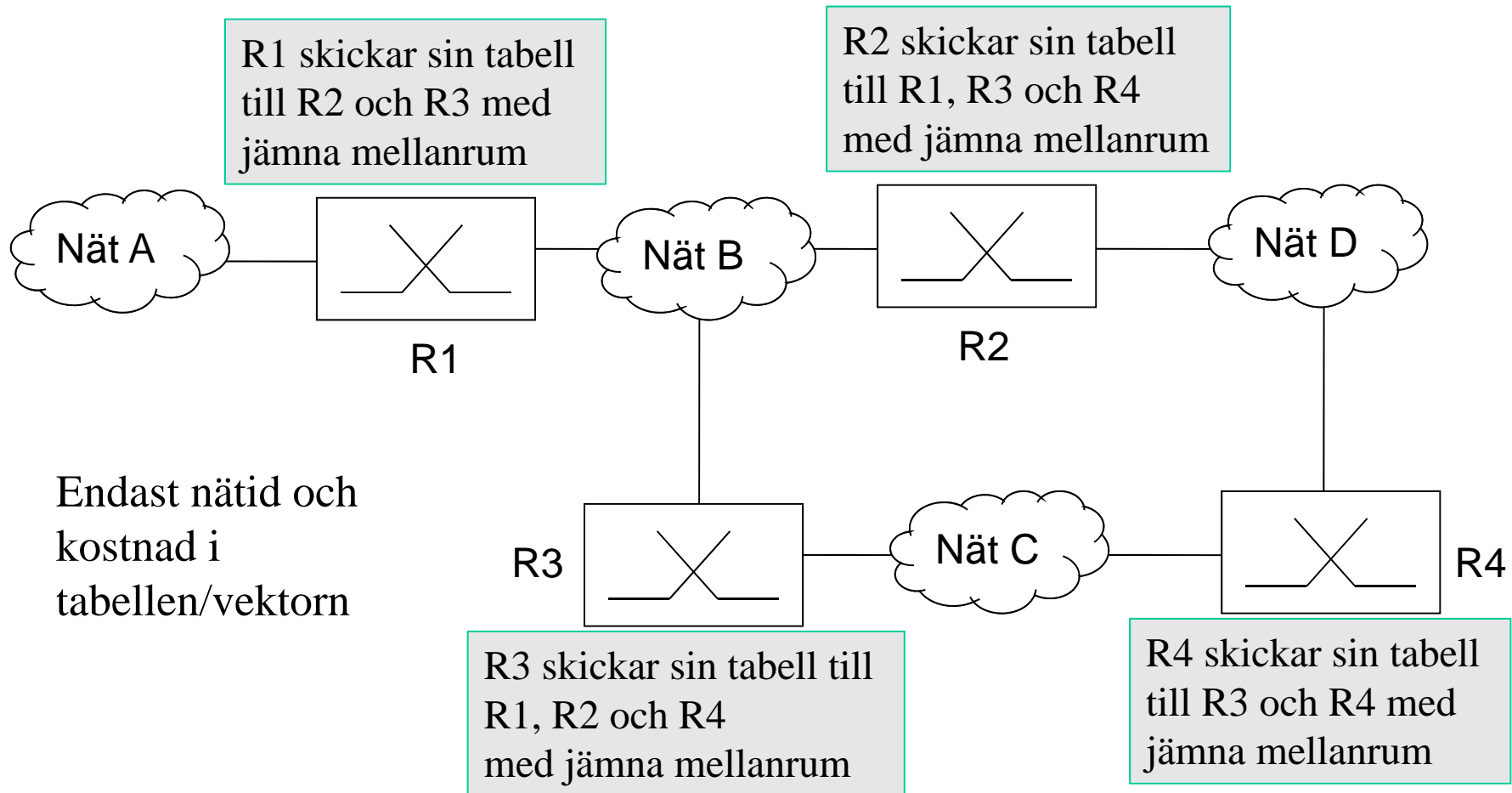

Distance vector: principle

- **Send** all known best paths to neighbours
 - Periodically
 - At changes
- **Update** routing tables with
 - New nodes
 - Change of cost or path
- "Global knowledge spread locally"

Exemple based on hop count

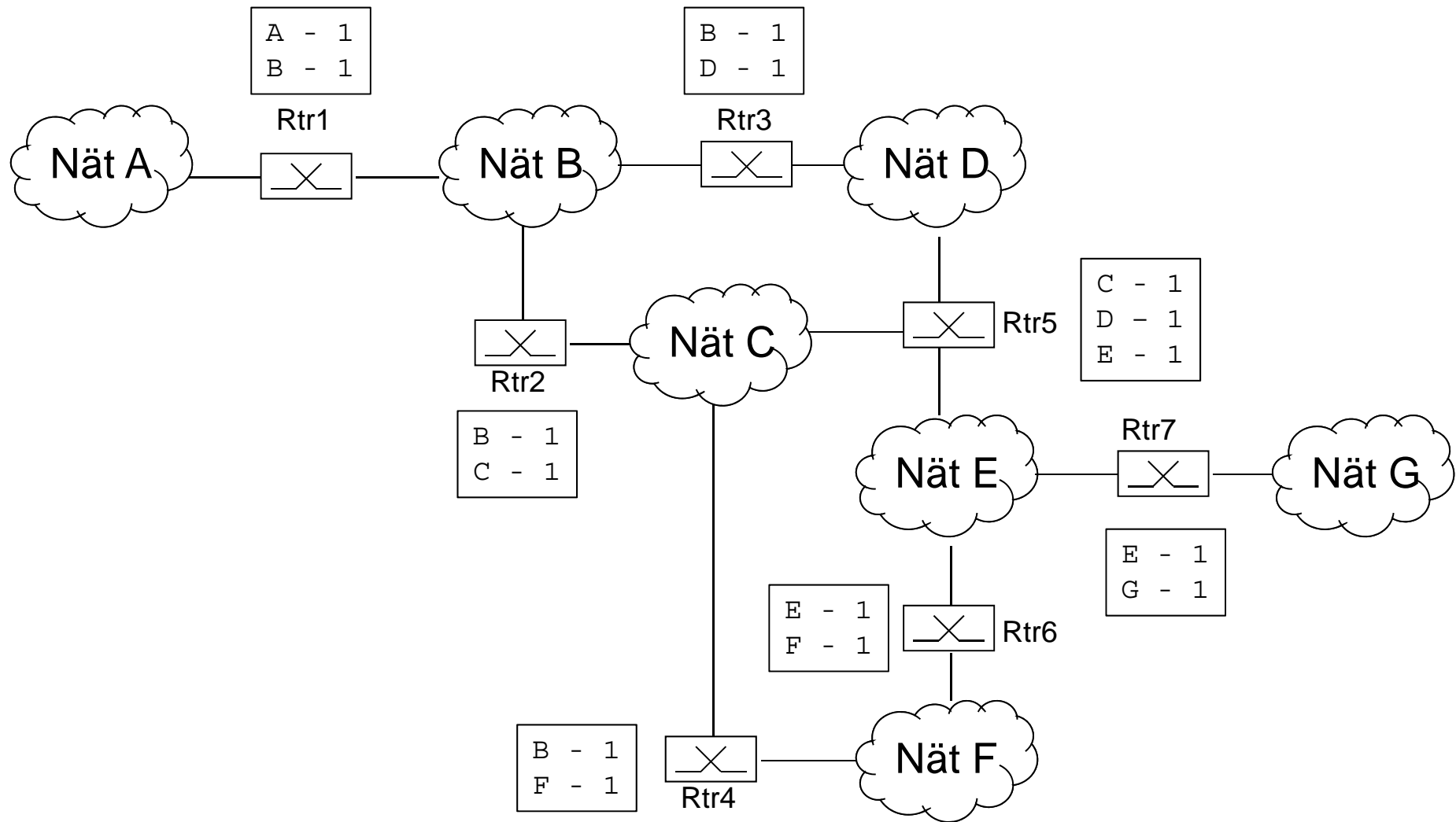

Bellman-Fords algorithm

```
(1)    if (advertised destination not in table) then
        update table
(2)    else
(2.a)  if (advertised next-hop = next-hop in table)
then
        replace entry
(2.b)  else
(2.b.i) if (advertised hop count < hop count in
table) then
        replace entry
(2.b.ii) else
        do nothing
```

Alternative: Bellman-Fords equation

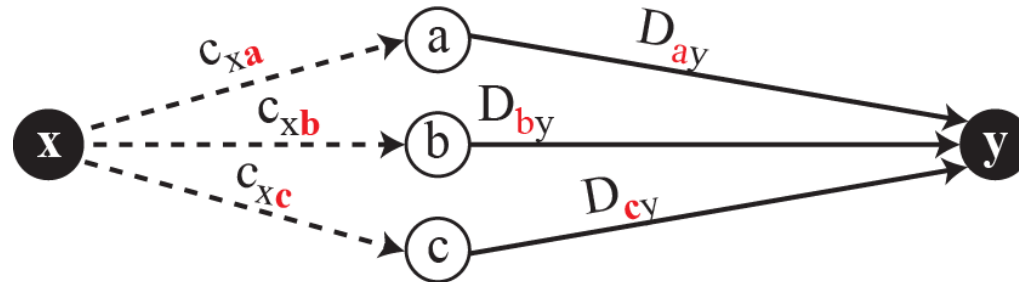

a. General case with three intermediate nodes

$$D_{xy} = \min\{(c_{xa} + D_{ay}), (c_{xb} + D_{by}), (c_{xc} + D_{cy}) \dots\}$$

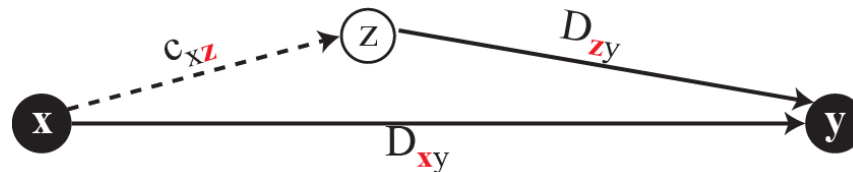

b. Updating a path with a new route

$$D_{xy} = \min\{D_{xy}, (c_{xz} + D_{zy})\}$$

Note! D_{xy} can change without node z being added!

Updates

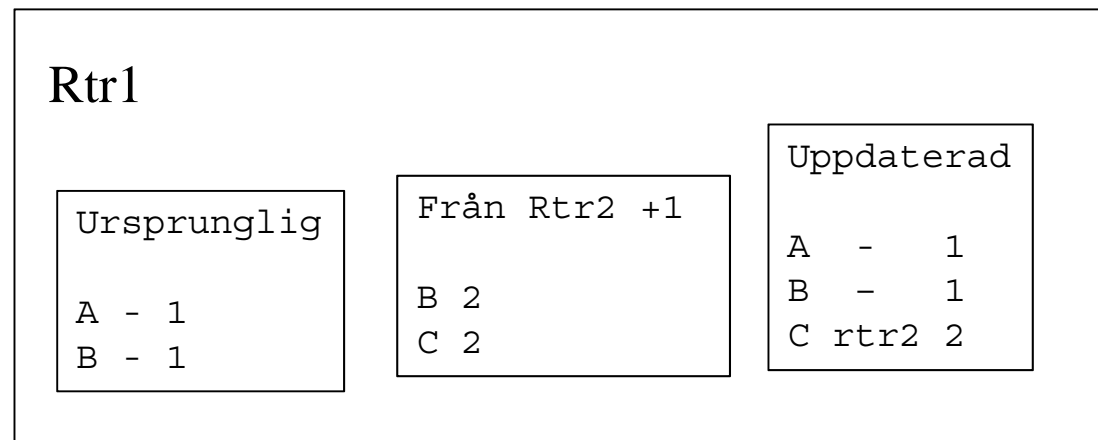
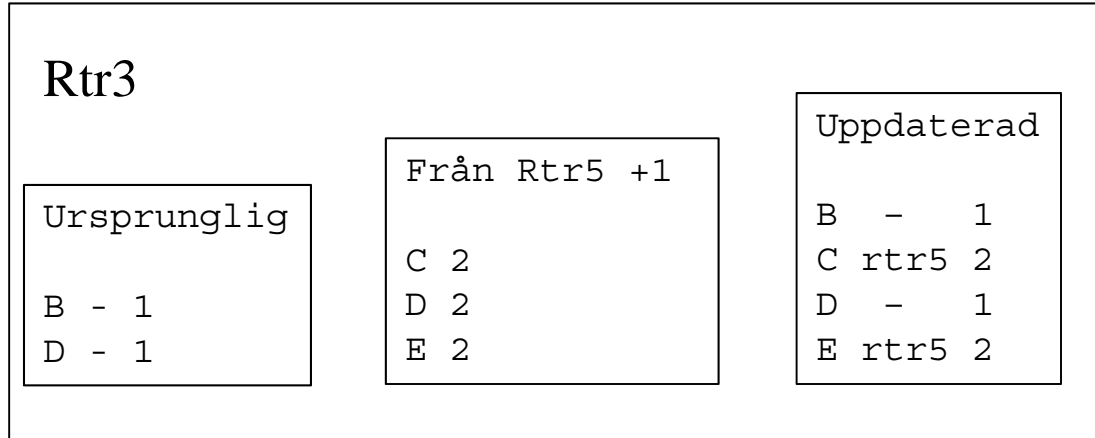

Distance Vector, reflections

- Periodic updates!?
 - How to find neighbours?
 - How to find out neighbour is lost?
- Problem with loss of links and nodes (behind neighbours).

More on distance vector

In ETSF10

- Count to infinity
- Two, three node instability
- Split Horizon
- Poison Reverse
- Routing protocol RIP

Link State: principle

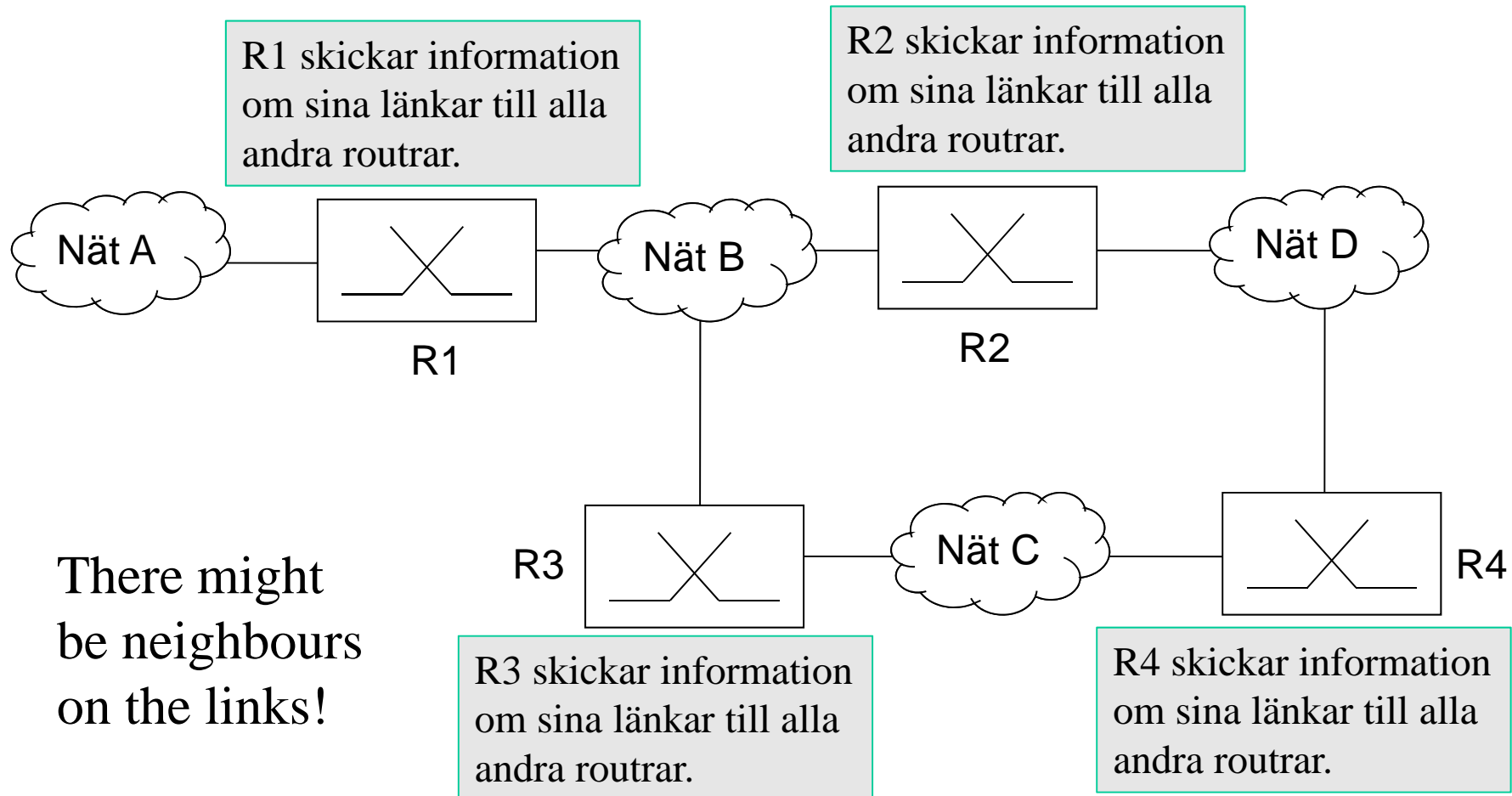

Link state: principle

- **Local topology** info is **flooded** globally (LSP)
 - Periodically (in practise very seldom, typically every hour)
 - On local changes
- Create database in each node with **all** link states
- Update routing table when new information is added to database (apply Shortest Path First)
- "Local knowledge spread globally"

LSP (Link State Packet)

Advertiser	Network	Cost	Neighbor
.
.
.

Link State Databas, exemple

Advertiser	Network	Cost	Neighbor
A	14	1	B
A	78	3	F
A	23	2	E
B	14	4	A
B	55	2	C
C	55	5	B
C	66	2	D
D	66	5	C
D	08	3	E
E	23	3	A
E	08	2	D
F	78	2	A
F	92	3	—

Link State: an exemple

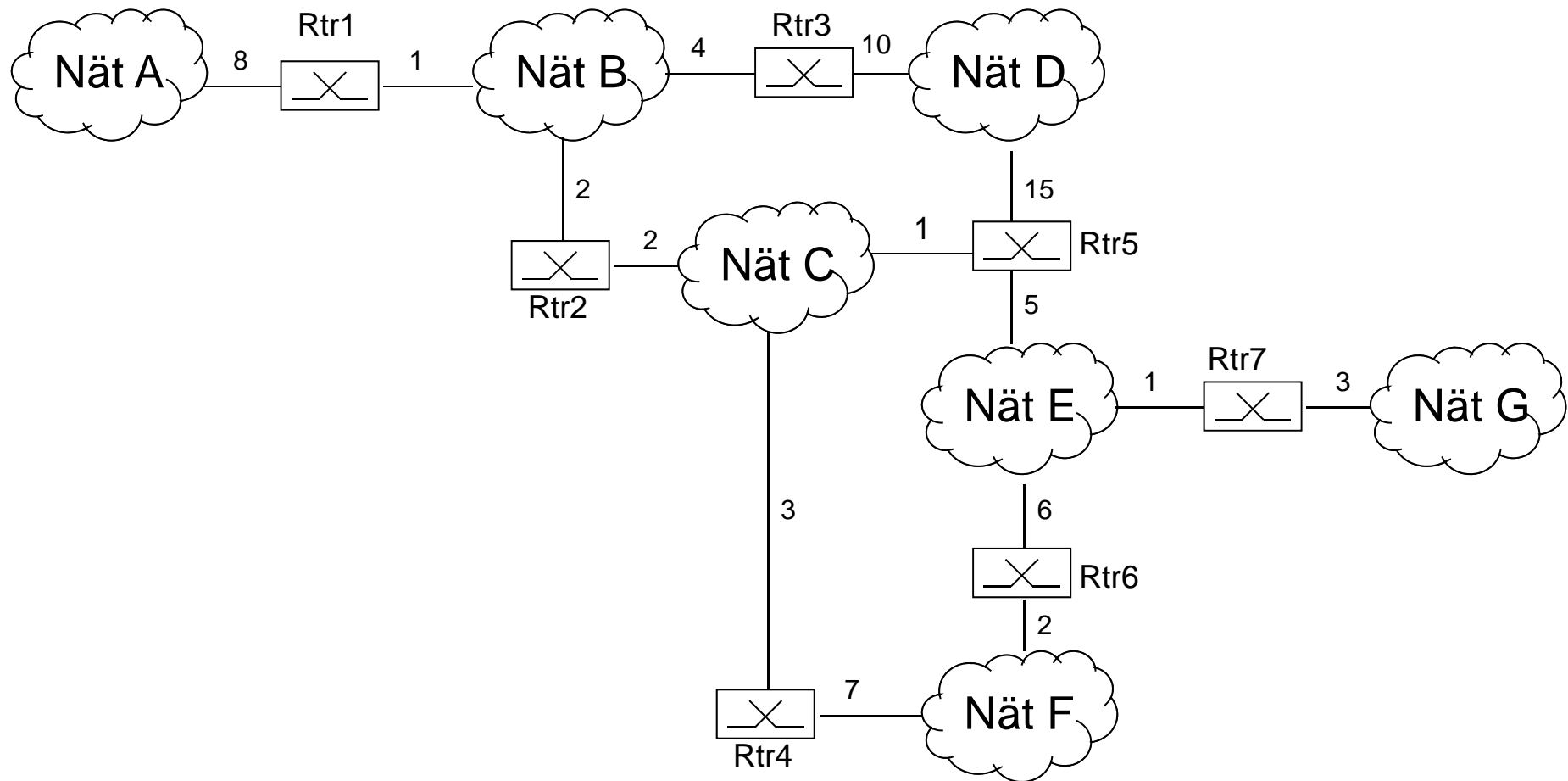

Dijkstra's algorithm: Shortest Path First

1. Identify the root (the node itself)
2. Attach all neighbor nodes temporarily
3. Make link and node with least cumulative cost permanent
4. Choose this node
5. Repeat 2 and 3 until all nodes are permanent

SFP: step 1 & 2 for rtr3

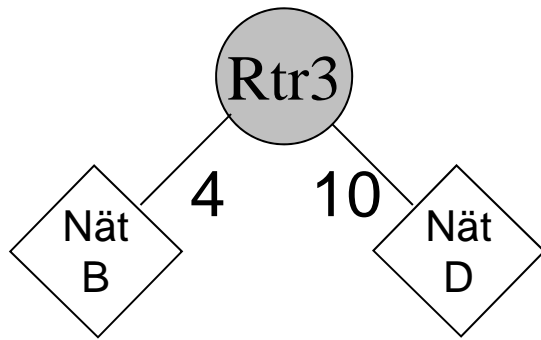

(a)

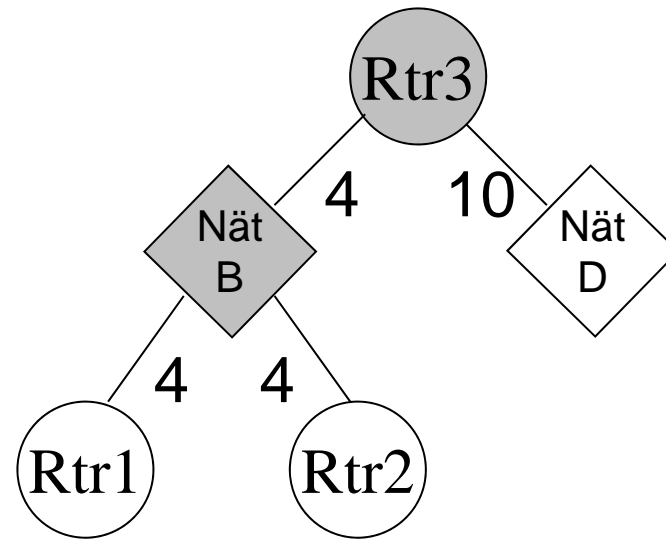

(b)

Final SFP tree for rtr3

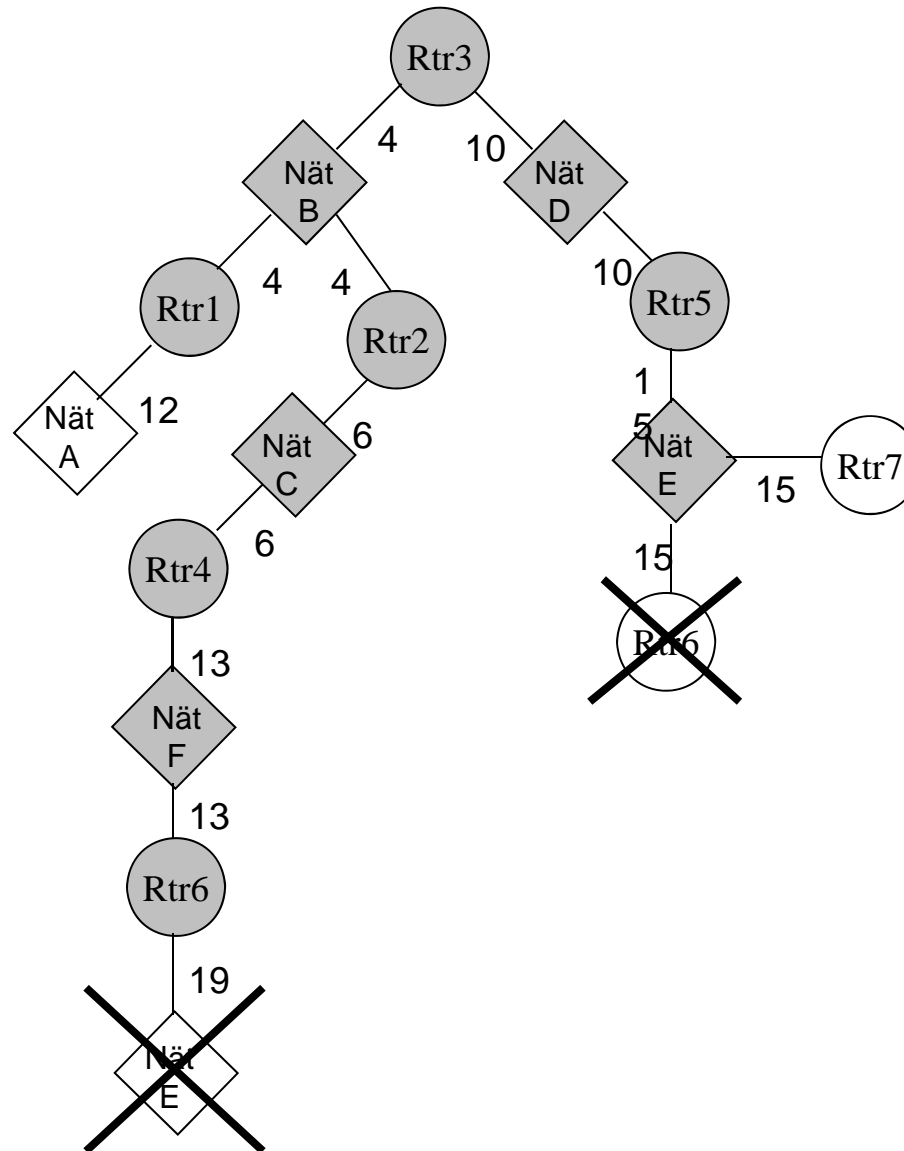

Routing table for rtr3

Nät-id	Next-hop	Kostnad
A	Rtr1	12
B	-	4
C	Rtr2	6
D	-	10
E	Rtr5	15
F	Rtr2	13
G	Rtr5	18

Link State, reflections

- Periodical updates!?
- Problem with lost links and nodes.
- How to find neighbours?
- How to find out neighbour is lost?

More on link state

In ETSF10:

- Routing protocol OSPF
- The concept of Areas or how to reduce flooding

Path Vector Routing

- “Distance Vector routing with add ons”
- In the routing table
 - Destination
 - Next-Hop
 - Path to destination
 - Or rather the path this routing information has taken
- BGP

Bonus material

- Concept Path Vector Routing
- Introduction to Multicast Routing

- More on this in ETSF10

Path Vector Routing Table

Network	Next Router	Path
N01	R01	AS14, AS23, AS67
N02	R05	AS22, AS67, AS05, AS89
N03	R06	AS67, AS89, AS09, AS34
N04	R12	AS62, AS02, AS09

AS = Autonomous System, approx = Organisation

Multicasting

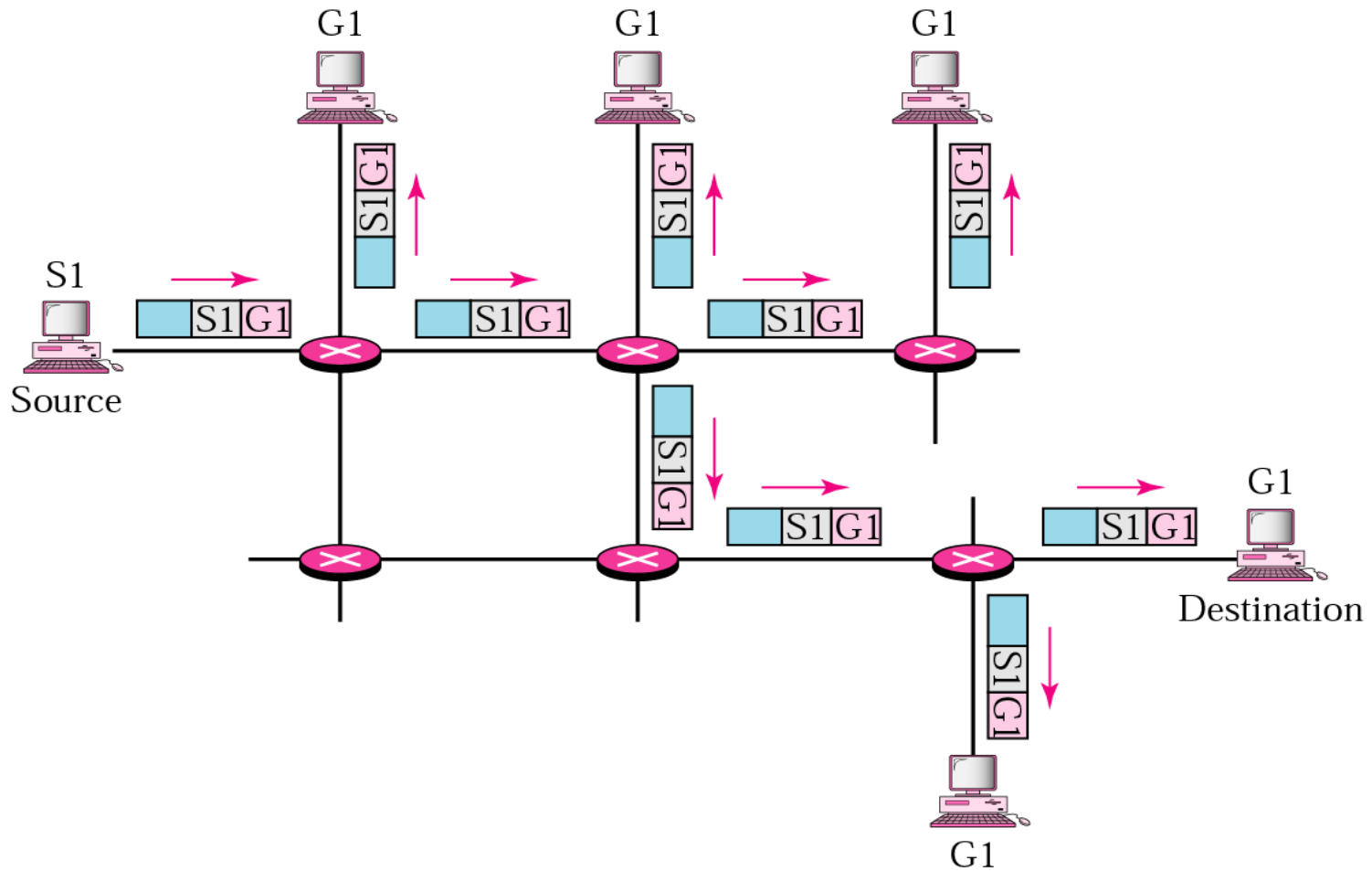

Basics for Multicast trees

- Destinationen is GROUP
- One and only one copy of each datagram to each group member
- No datagrams to non members
- Avoid looping datagrams
- Optimal paths source – members
(*shortest path*)

Multicast Routing protocols

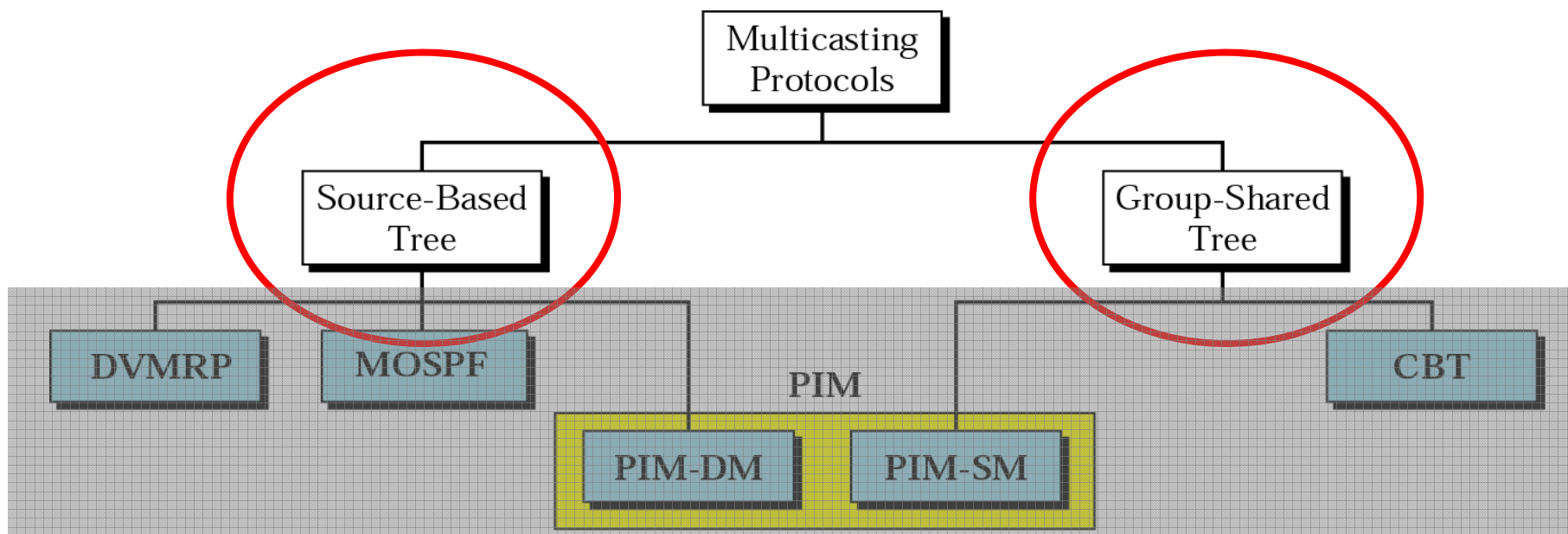

Source Based Tree

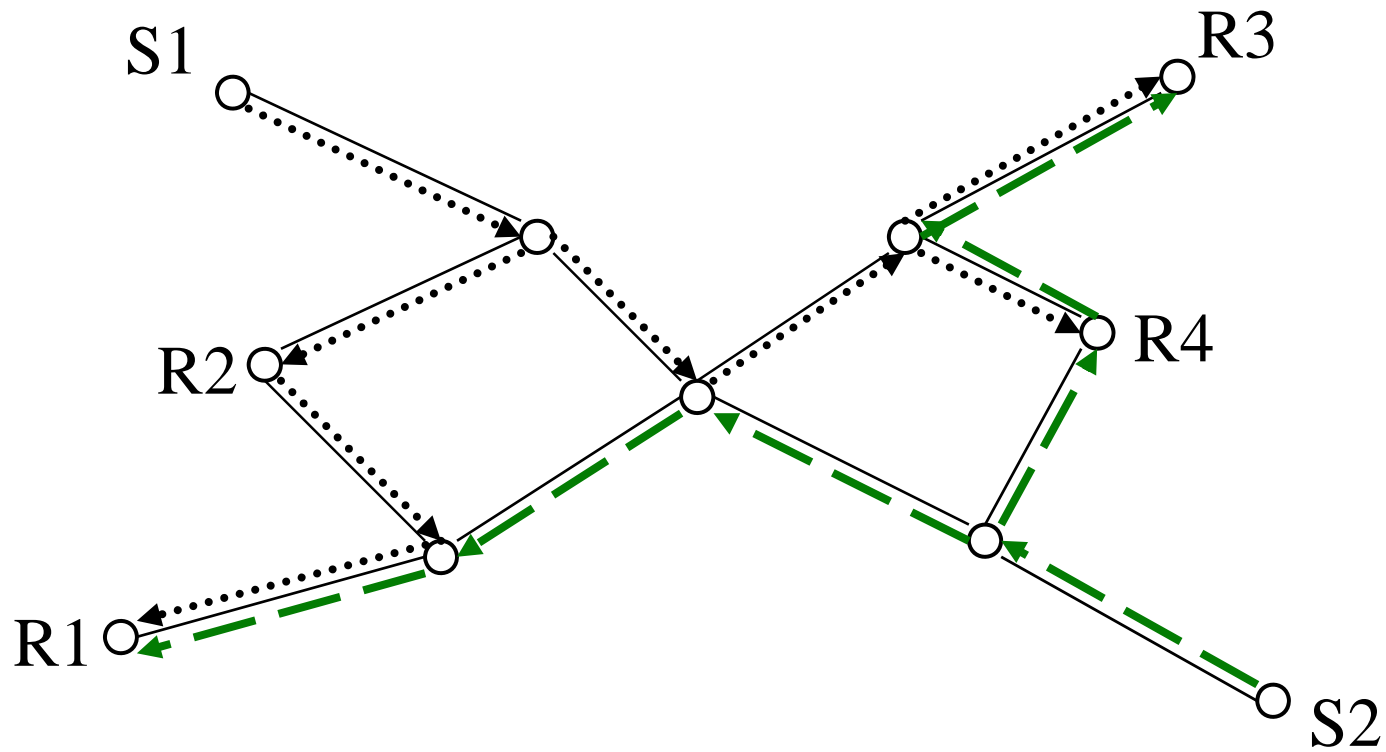

one tree per source

Group Shared Tree

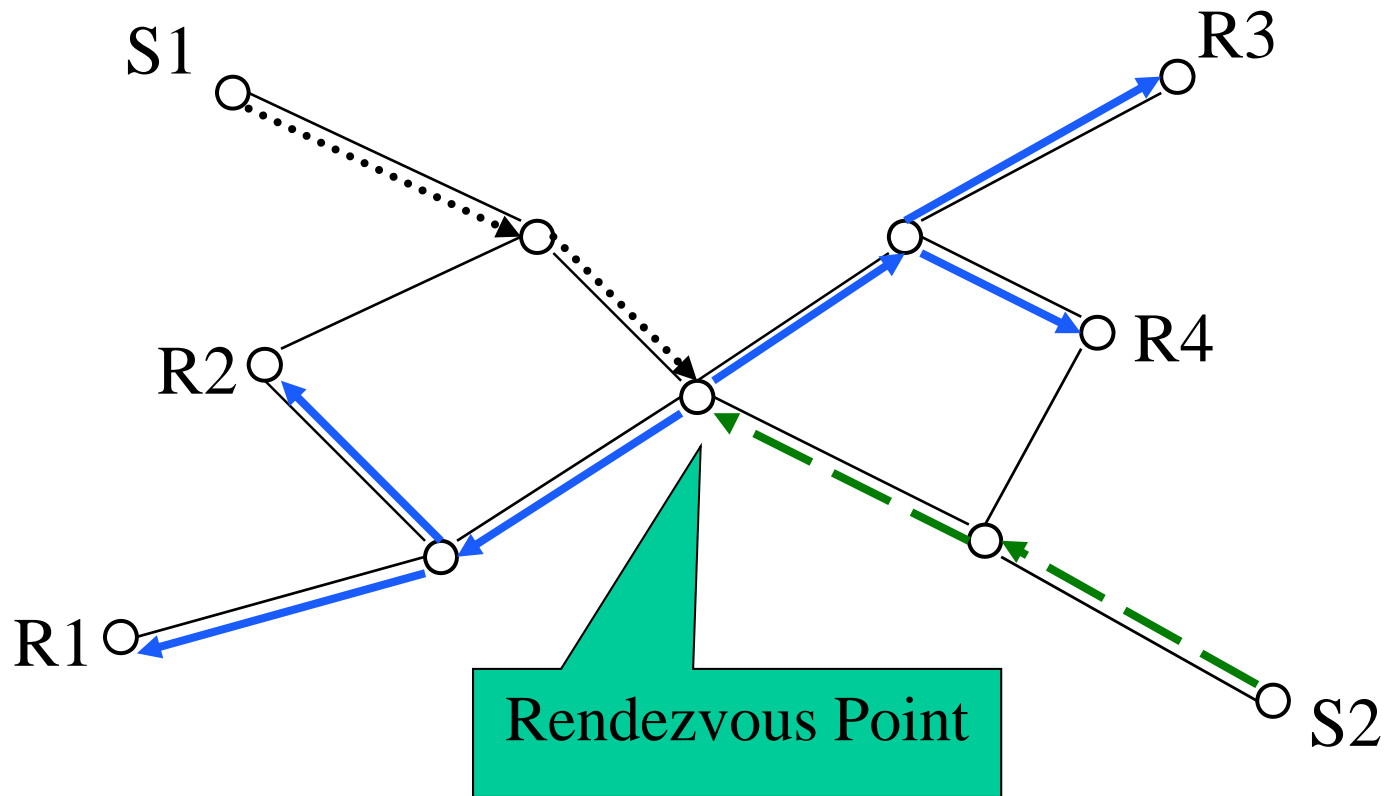

one tree per group

Reverse Path Forwarding

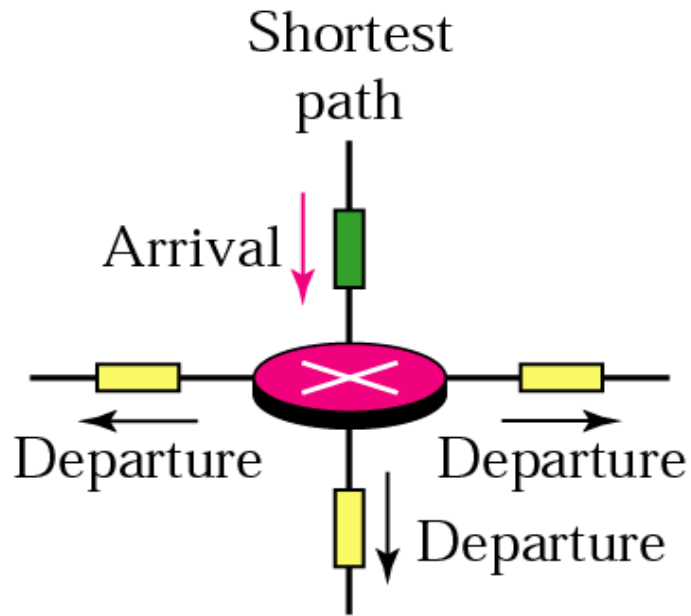

a. Packet is forwarded

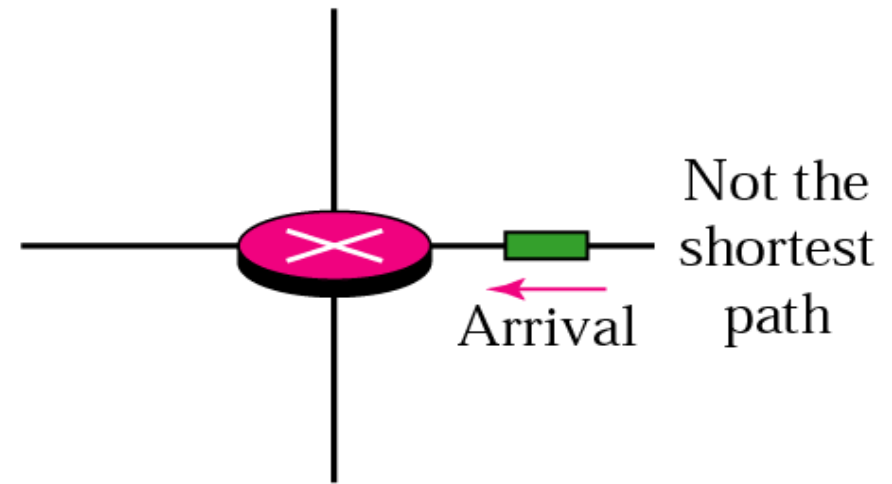

b. Packet is discarded

Routing per source address!